

BENCHMARK:
 Small RR Spike in W. Face of
 Power Pole 59' S. and 52.5' E.
 of NW Cor., SW 1/4, Sec. 14,
 TWP. 28-S, R-1-W.
 Elev. = 125.38 City Datum
 (1312.78 NGVD)

Small RR Spike in SW Face of
 12" Tree 15.5' E. of NE Cor.,
 Hope Community Baptist Church
 Addition.
 Elev. = 125.27 City Datum
 (1312.67 NGVD)

P.V.I.
 Elev. = 123.40
 50' V.C.

P.V.I.
 Elev. = 120.90
 No V.C.

Scale: 1" = 20' Horizontal
 1" = 5' Vertical
 • = Iron

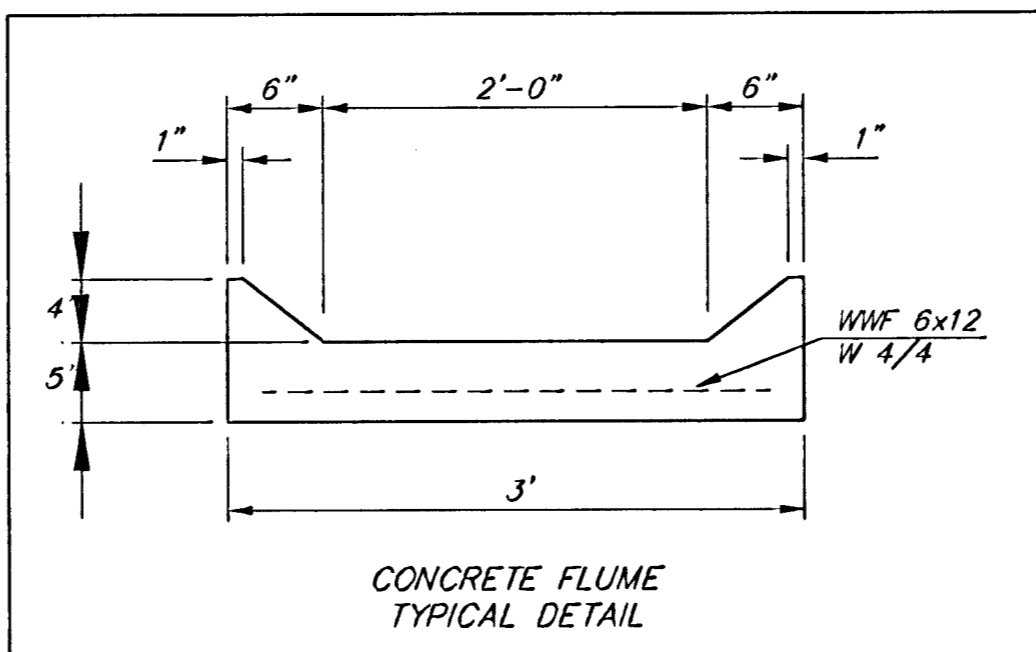
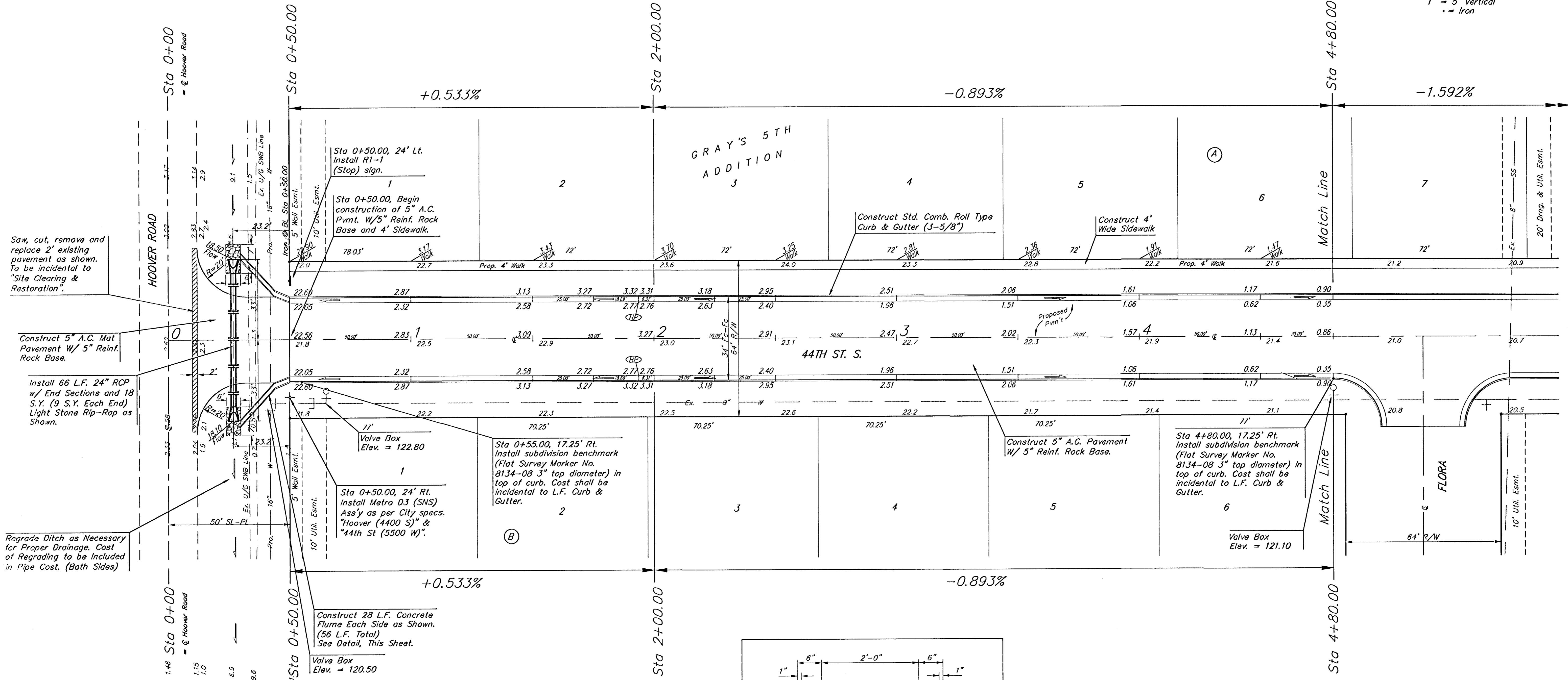

NOTE: ROLL TYPE CURB & GUTTER TO BE CONSTRUCTED ON THE PAVEMENT SHOWN ON THIS SHEET. TOP OF CURB ELEVATIONS ARE GIVEN FOR FULL HEIGHT CURB.

GRAY'S 5TH ADDITION - PHASE 1
44TH STREET SOUTH
 STA 0+00 TO STA 4+80.00

BAUGHMAN COMPANY P.A.
 ENGINEERING, SURVEYING, & PLANNING
 316-262-7271 • 315 ELLIS • WICHITA, KANSAS 67211

PROJECT NUMBER
472-83552

DESIGN: NBW DRAWN: TMS APPROVED: DATE: 06/02 SCALE: Noted

SHEET **6** OF **23**