

F:\Projects\Projects 4700-4799\4796E (Casa Bella Phase 4 Engineering)\4796E Easement Grading.dwg

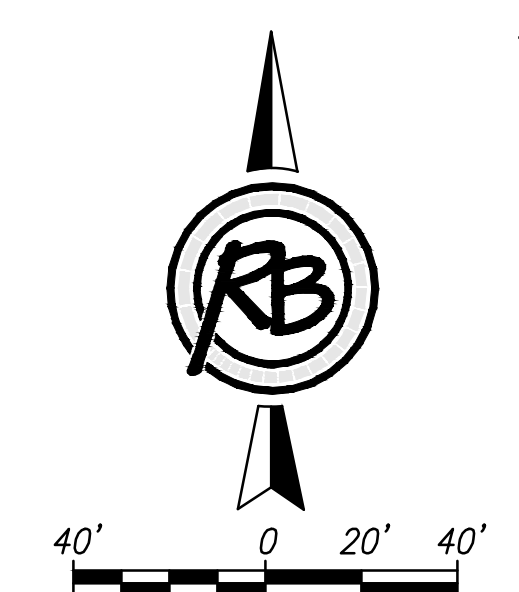
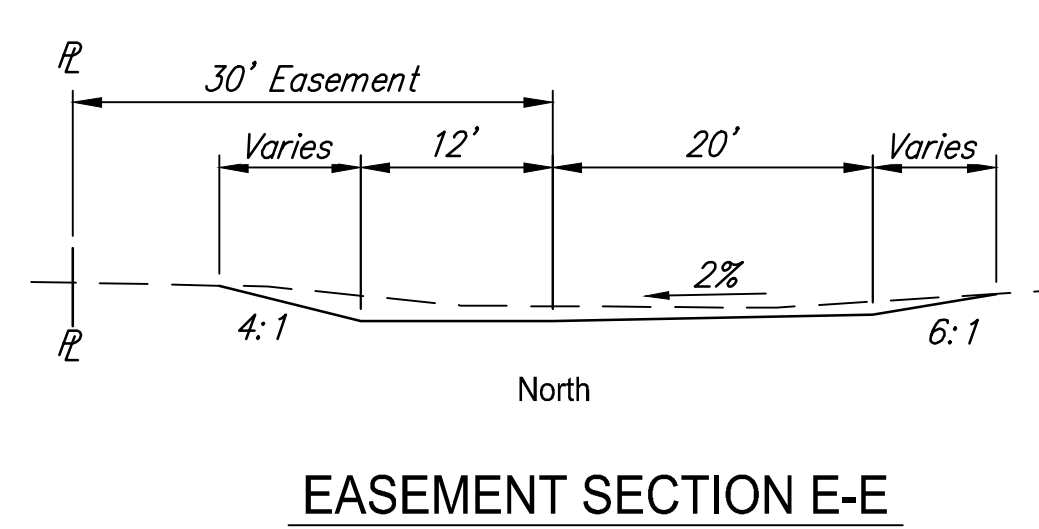
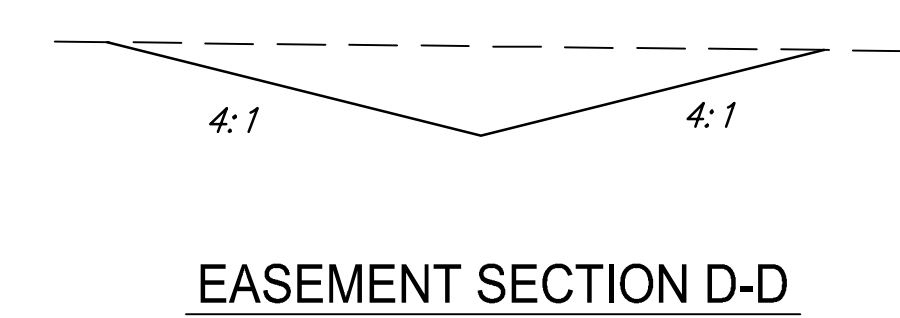
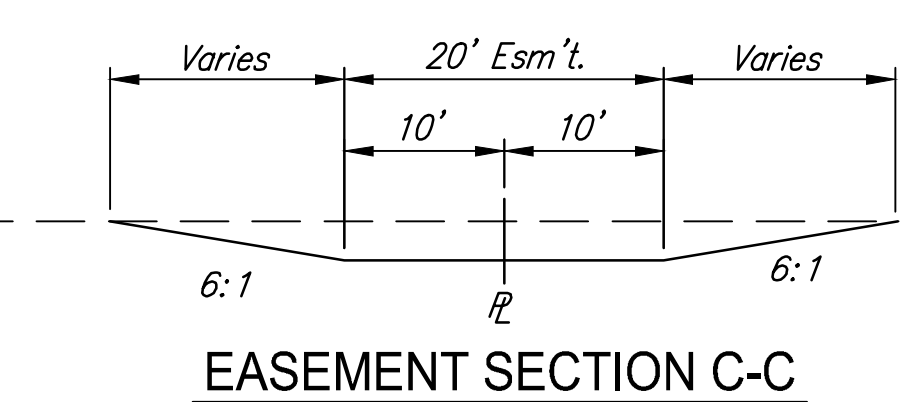
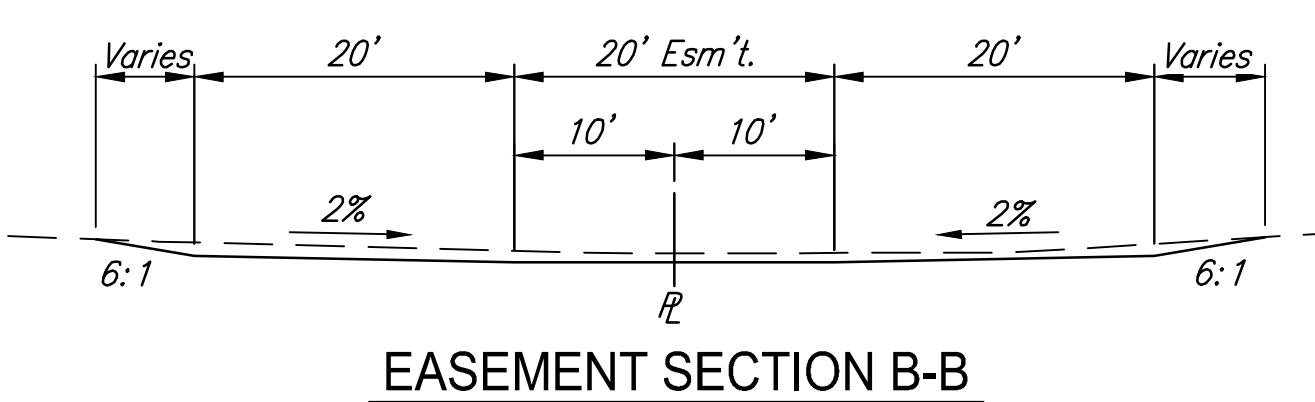
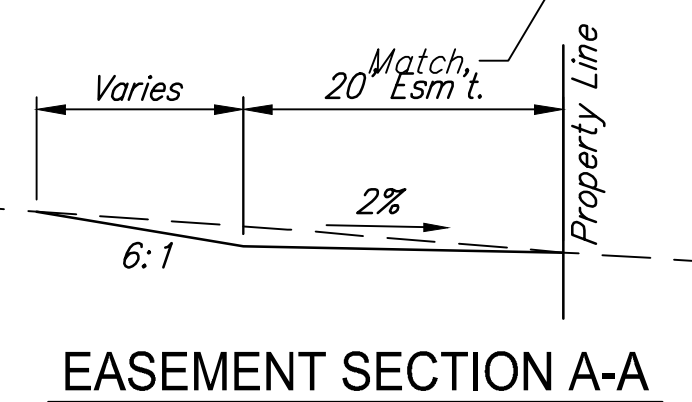

Casa Bella 2nd - Phase 4 Easement Grading		DATE
RUGGLES & BOHM		DESIGN
<small>ENGINEERING SURVEYING LANDSCAPE ARCHITECTURE GOVERNMENT</small>		KWL
<small>924 NORTH MAIN WICHITA, KANSAS 67203 P (316) 264-8008 F (316) 264-4621 WWW.RBANS.COM</small>		DRAWN
<small>PROJECT NUMBER 472-85321 4796E DWG. SCALE</small>		DRS
<small>DRAWING FILE 4796E Easement Grading [Easement Grading]</small>		REVIEW
<small>(c) Copyright 2015, Ruggles & Bohm, P.A.</small>		2-8-2017
<small>17</small>		SHEET
<small>32</small>		OF