

**BENCHMARKS:**

BM#1: Disc on Top of Curb  
South side of 27th St. N. and  
West of 27th Ct. N. Woods  
North 3rd Addition  
Elev. = 1397.69 NAVD88

BM#2: Northwest 1/4 Corner  
Government Lot 2, Sec. 3,  
TWP. 27-S, R-2-E  
Elev. = 1405.78 NAVD88

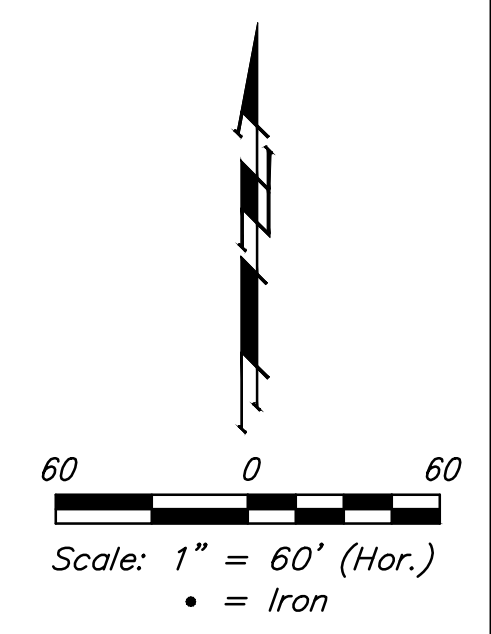
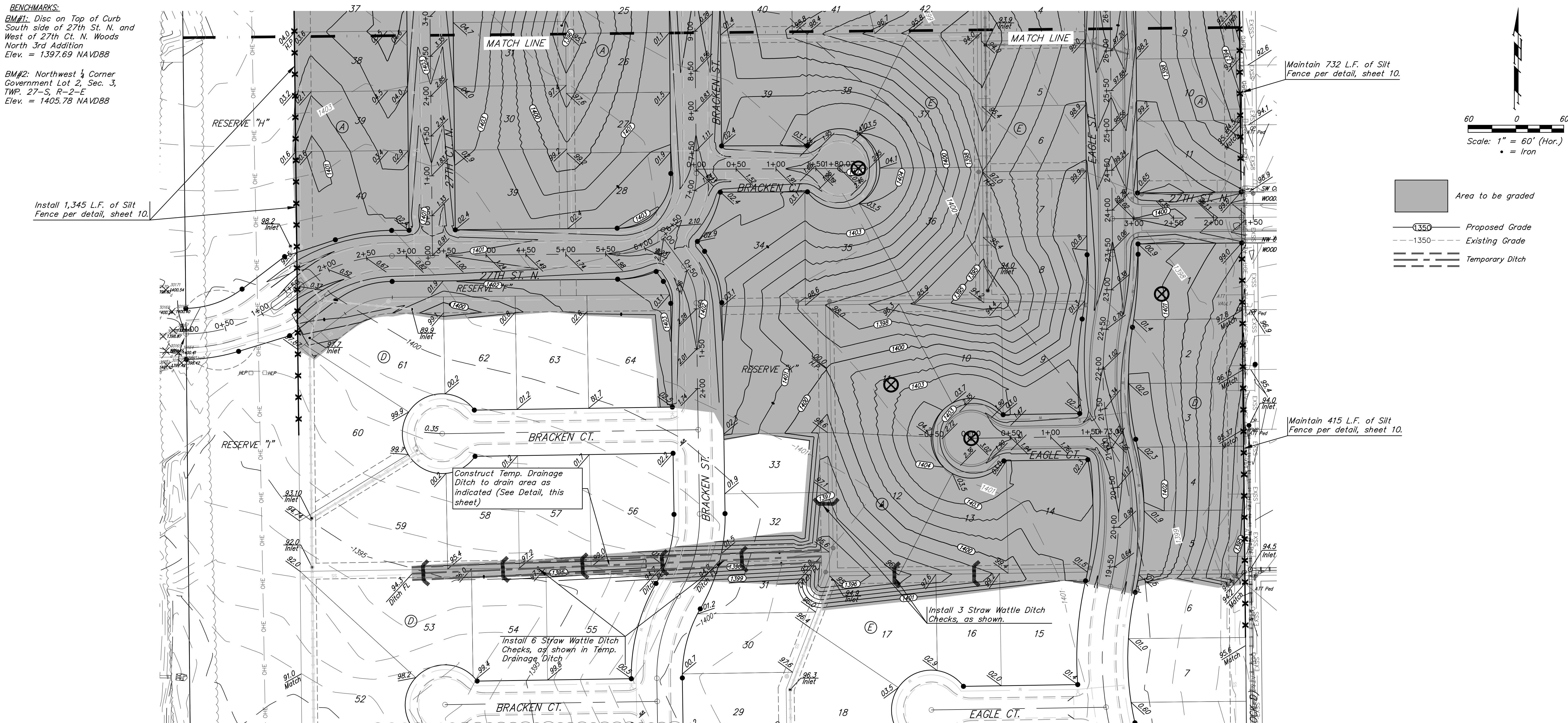

- Area to be graded
- 1350 Proposed Grade
- 1350 Existing Grade
- Temporary Ditch

Description	Location			Compaction % and Test Elevation											
	Northing	Easting	Elev.	1394	1395	1396	1397	1398	1399	1400	1401	1402	1403	1404	1405
Lot 1, Block A	9810.500	19291.253	1399.58	X						X	X	X	X	X	X
Lot 2, Block A	9853.509	19222.112	1399.88	X	X					X	X	X	X	X	X
Shadowridge St. ~Sta. 1+50	9777.057	19099.733	1401.34	X	X	X						X	X	X	X
Pepperwood/Shadowridge St.	9624.566	18827.846	1402.65	X	X	X	X	X	X	X			X	X	X
Lot 4, Block B	9714.312	18891.124	1403.62	X	X	X	X	X	X				X	X	X
Lot 17, Block A	9455.216	19049.208	1401.20	X	X	X						X	X	X	X
Lot 21, Block A	9606.558	19304.229	1399.35	X						X	X	X	X	X	X
Lot 33, Block A	9185.114	18955.796	1402.18	X	X	X	X	X	X				X	X	X
Lot 34, Block A	9275.128	18913.988	1401.17	X	X	X	X	X	X			X	X	X	X
27th Ct. N. CDS	9171.083	18856.186	1405.25	X	X	X	X	X	X						
Lot 36, Block A	9138.997	18792.167	1405.34	X	X	X	X	X	X	X					
Lot 5, Block C	9372.098	19810.377	1395.34			X	X	X	X	X	X	X	X	X	X
Eagle St. ~Sta. 28+50	9281.505	19708.879	1398.39	X	X					X	X	X	X	X	X
Lot 6, Block C	9276.417	19805.953	1395.88	X		X	X	X	X	X	X	X	X	X	X
Lot 7, Block C	9198.506	19806.712	1395.22	X	X	X	X	X	X	X	X	X	X	X	X
Lot 43, Block E	9210.428	19438.149	1402.03	X	X	X	X	X	X			X	X	X	X
Bracken Ct. CDS	8865.731	19395.061	1403.05	X	X	X	X	X	X				X	X	X
Lot 1, Block D	8708.107	19775.560	1401.08	X	X	X	X	X	X			X	X	X	X
Lot 11, Block E	8594.264	19436.058	1402.45	X	X	X	X	X	X	X			X	X	X
Eagle Ct. CDS	8527.058	19536.427	1403.02	X	X	X	X	X	X				X	X	X

⊗ Compaction Testing Location  
X - Compaction Test not Required at this elevation.

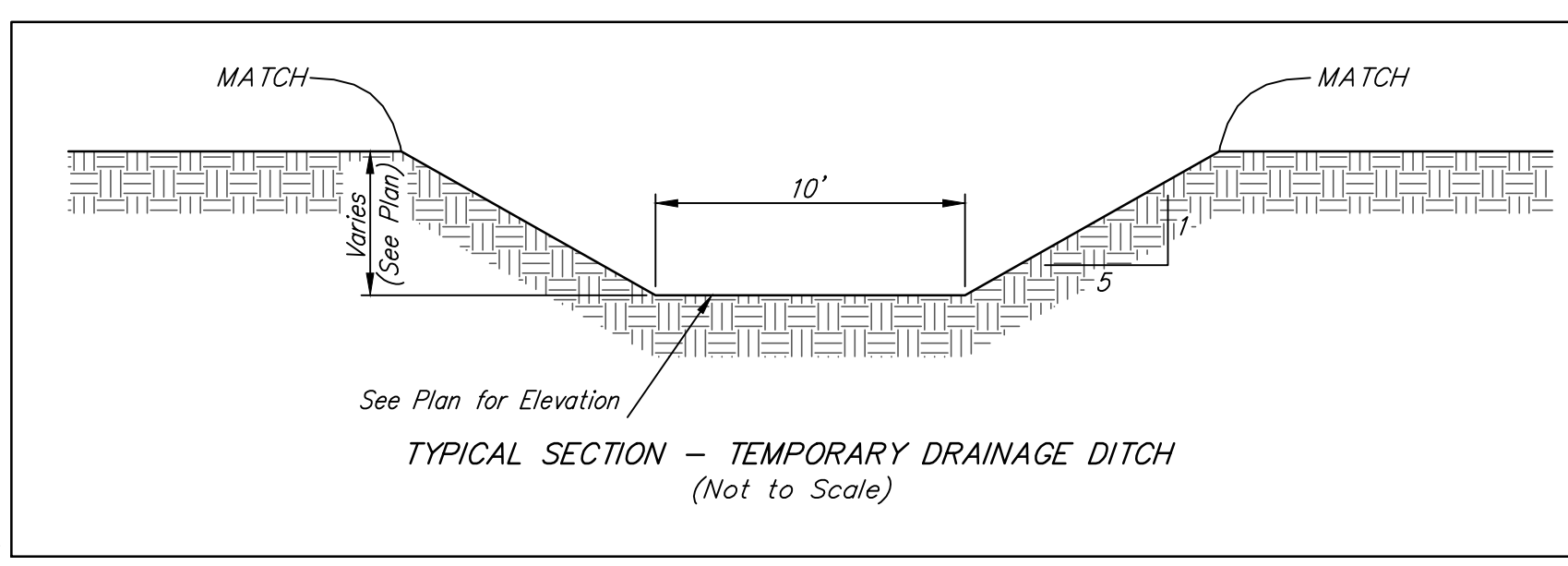

**Baughman**

Firefly Way Addition Phase I  
**MASS GRADING  
EROSION CONTROL**  
Storm Water Drain #419

Baughman Company, P.A. 315 Ellis St. Wichita, KS 67211 P 316-262-7271 F 316-262-0149  
ENGINEERING | SURVEYING | PLANNING | LANDSCAPE ARCHITECTURE

PROJECT NUMBER  
468-85185

REVISIONS:

DESIGN  
AEG

APPROVED

SCALE  
Noted

SHEET

DRAWN  
DJL

DATE  
2/17

6 OF 17