

Combined Curb & Gutter (6")

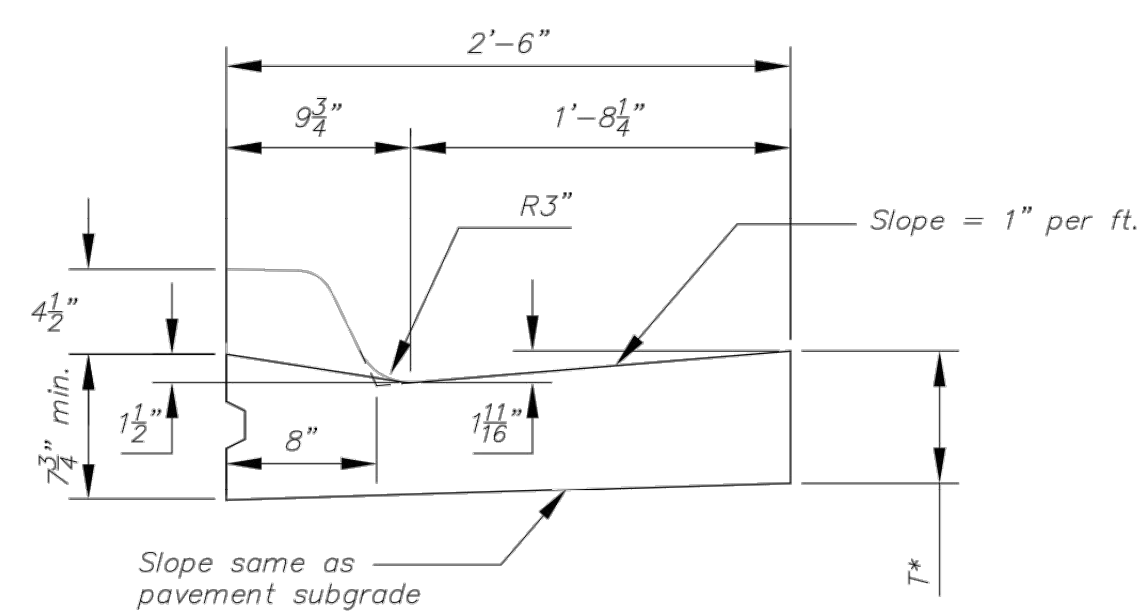

Combined Curb & Gutter (1 1/2")

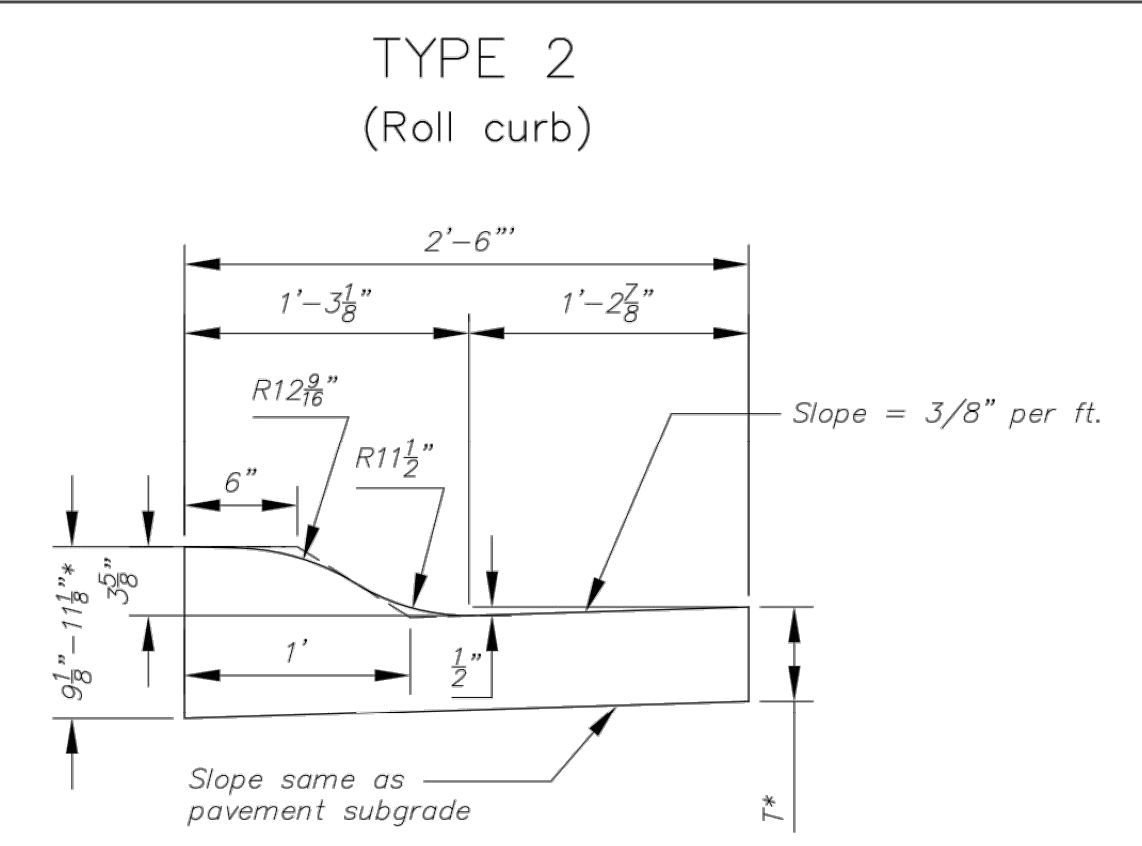

Combined Curb & Gutter (3 5/8")

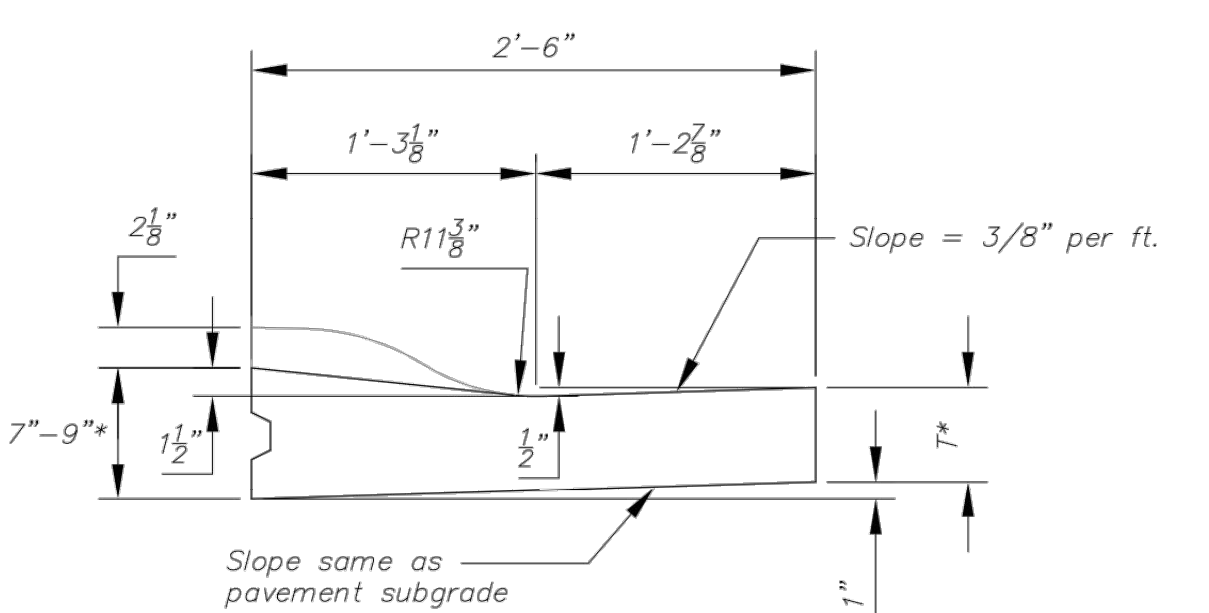

Combined Curb & Gutter (1 1/2")

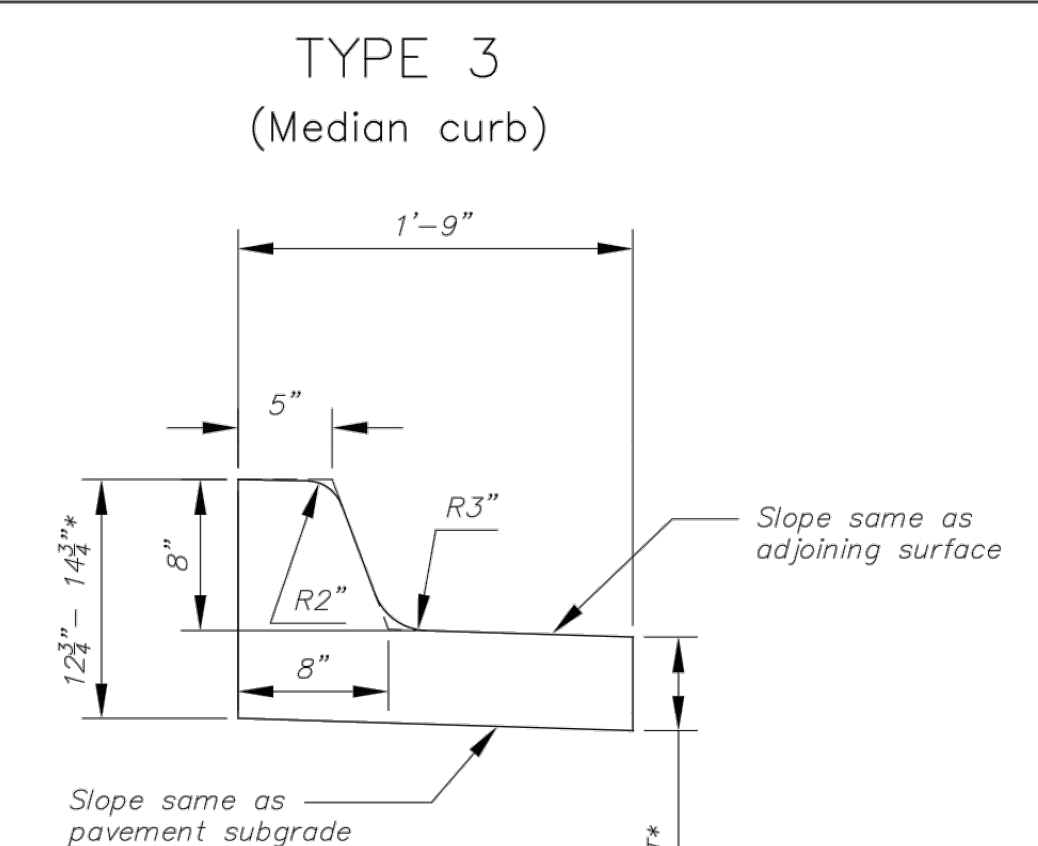

Combined Curb & Gutter (8")

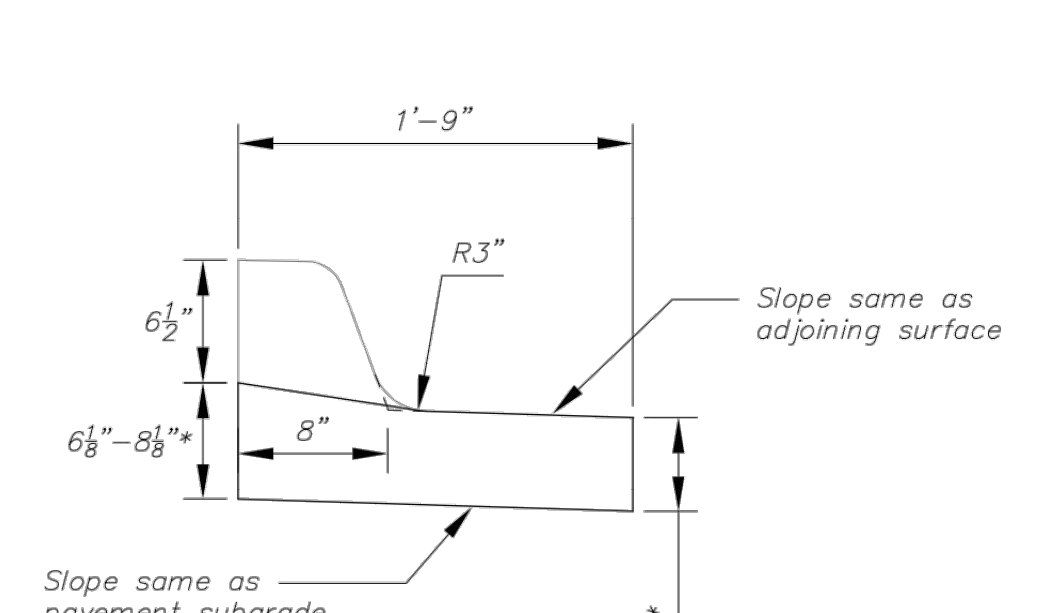

Combined Curb & Gutter (1 1/2")

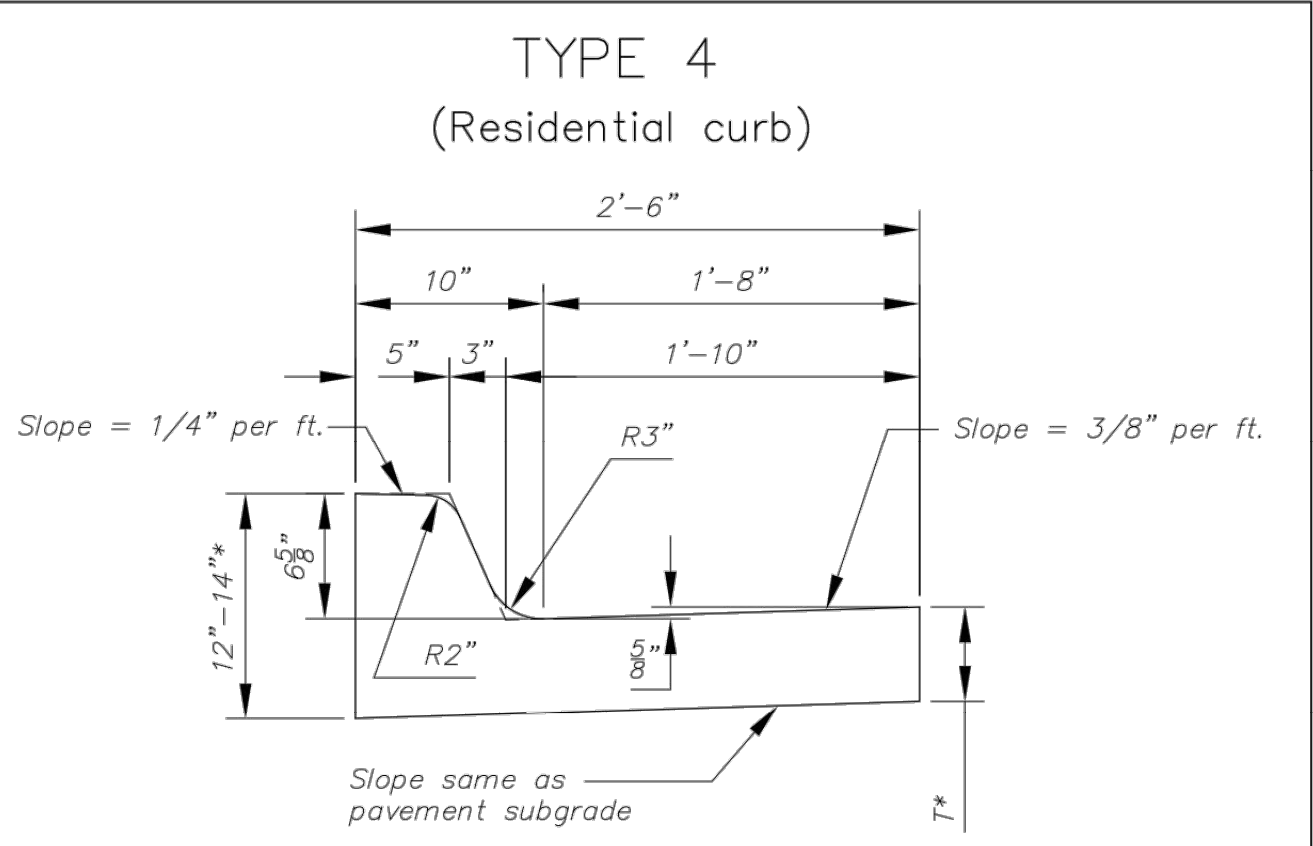

Combined Curb & Gutter (6 5/8")

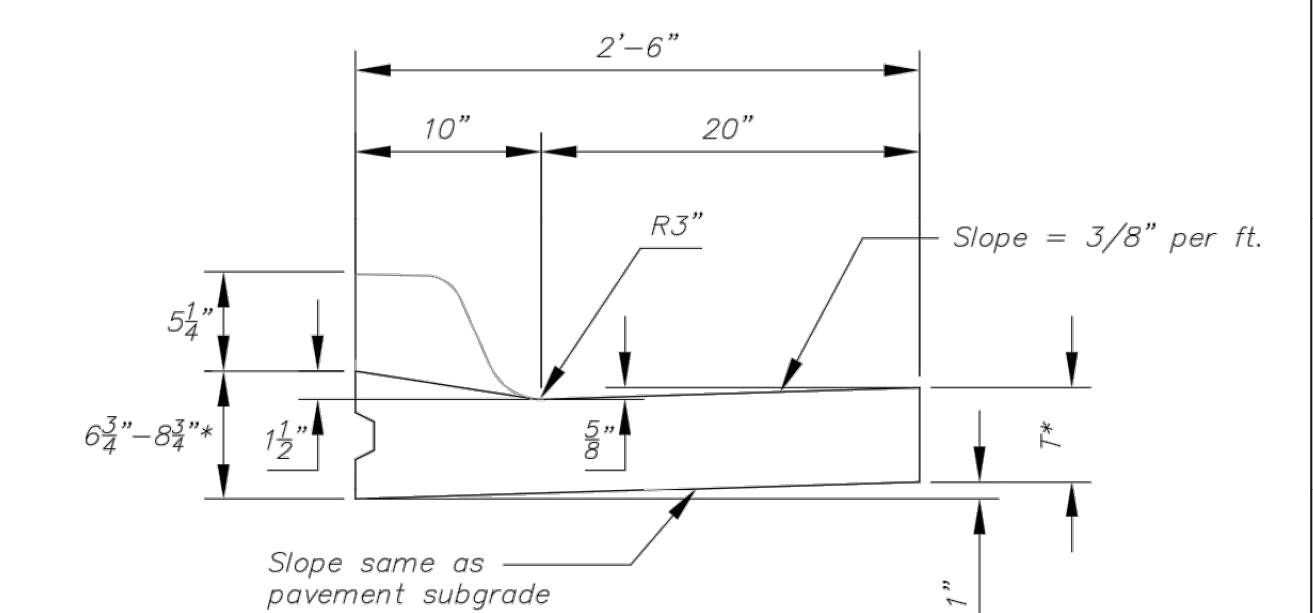

Combined Curb & Gutter (1 1/2")

T* = Thickness of curb to adjust with pavement thickness

GENERAL NOTES

- Expansion (isolation) joints shall be constructed a maximum of 300' apart and at all Pls, PCs, cul-de-sac quadrants, and ends of returns.
- Contraction joints shall be constructed a minimum of 12' apart.
- Joint sealer shall be required at all joints on arterial and industrial streets and at intersections on residential streets.

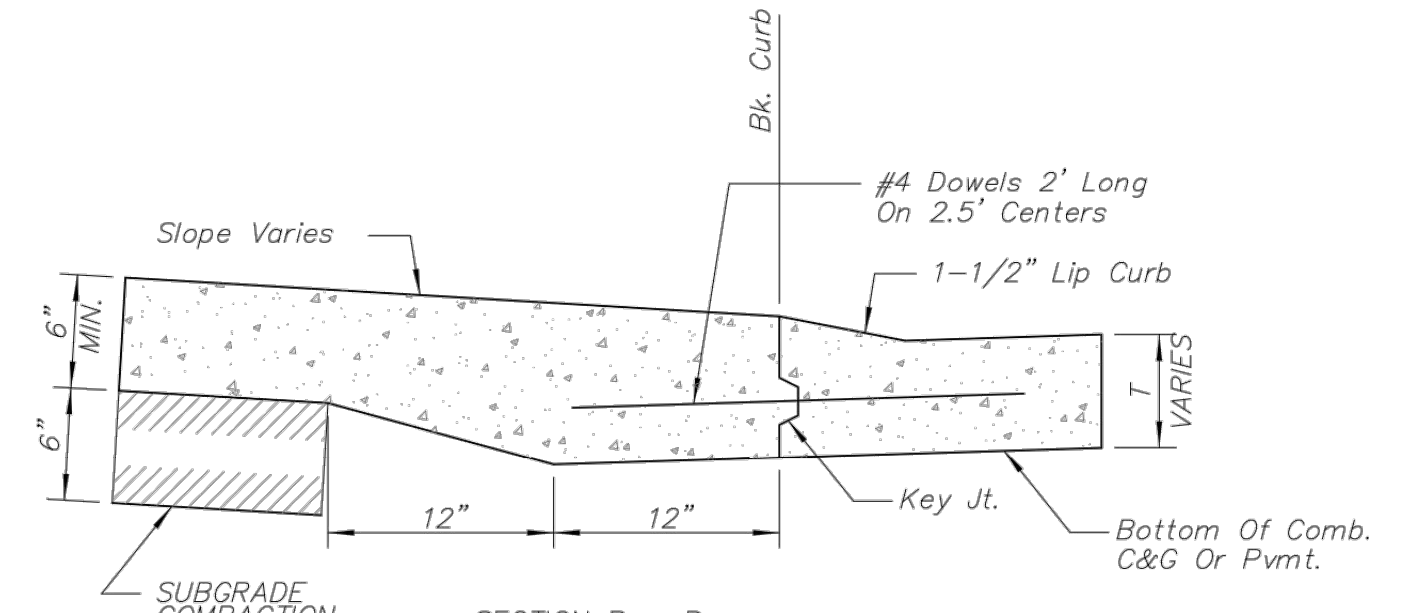

SECTION B - B
BACK OF CURB DETAIL

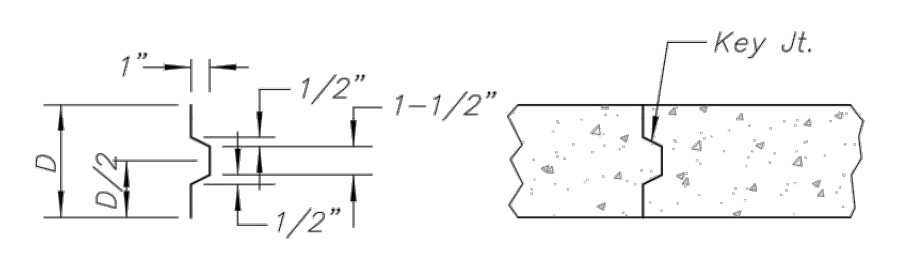

ALT. LONGITUDINAL CONSTRUCTION JOINT

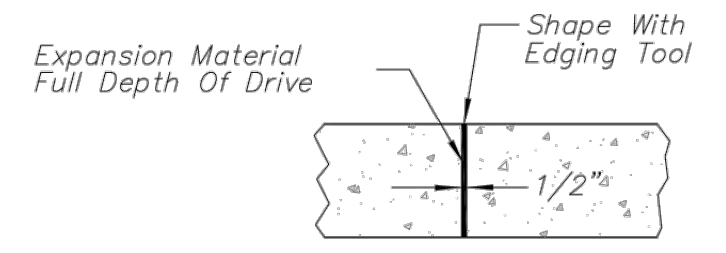

EXPANSION JOINT (E.J.)

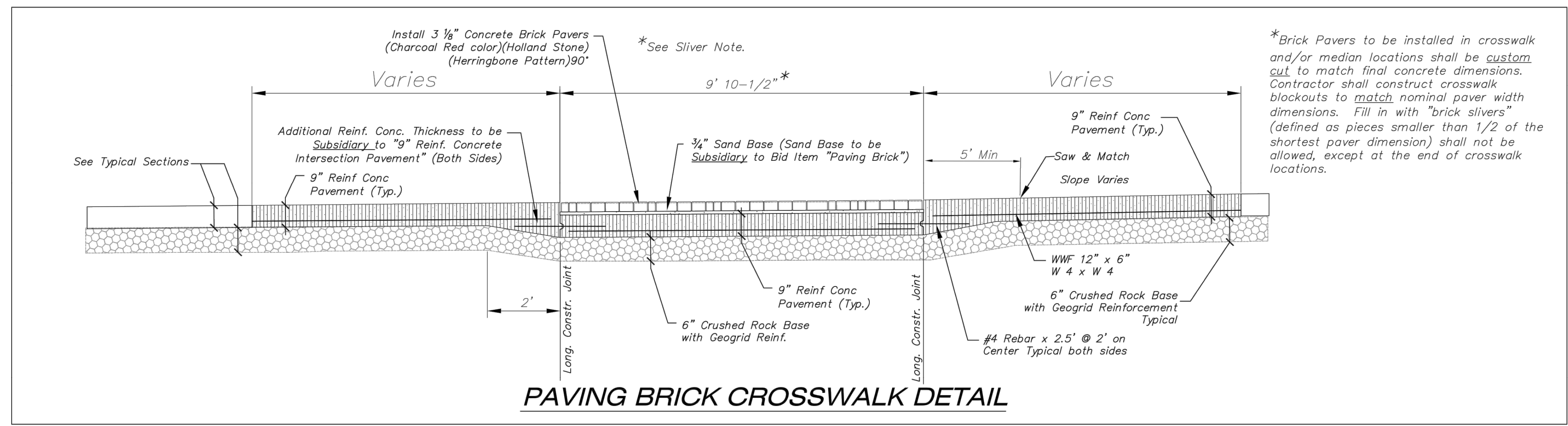

PAVING BRICK CROSSWALK DETAIL



<p>REVISED: OCTOBER 2015</p> <p>CURB & GUTTER & PAVING BRICK CROSSWALK DETAILS</p> <p>CITY ENGINEER GARY JANZEN, P.E.</p>		
PROJECT NUMBER	OCA NUMBER	DATE
CITY ENGINEER'S OFFICE		SHEET
CITY HALL - SEVENTH FLOOR		
455 NORTH MAIN STREET		
WICHITA, KANSAS 67202-1620		
(316) 268-4501		

PROJ. NO.	F16D0205
DESIGNER	KDB
CFN	0205DET
SHEET	6 OF 36
REV	0
DATE	6-7-17
BID SET	0
DESCRIPTION	DSN DWN CHK
DATE	06-07-17
REV	0
DATE	06-07-17
DESCRIPTION	DSN DWN CHK
DATE	06-07-17
REV	0
DESCRIPTION	DSN DWN CHK

KAW VALLEY ENGINEERING

1104 E. 12TH AVENUE
EMPORIA, KANSAS 66801
PH. (620) 208-5240 | FAX (785) 762-7744
emp@kveeng.com | www.kveeng.com

KAW VALLEY ENGINEERING
KAW VALLEY ENGINEERING, INC. IS AUTHORIZED TO OFFER ENGINEERING SERVICES BY KANSAS STATE CERTIFICATE OF AUTHORIZATION # E-113. EXPIRES 12/31/18

CENTRAL AND NIMS SIGNALIZATION
PROJECT NUMBER 472-85280
WICHITA, KANSAS

CURB AND GUTTER DETAILS