

FHWA REGION NO.	STATE	PROJECT NO.	FISCAL YEAR	SHEET NO.	TOTAL SHEETS
7	KANSAS	U-0639-01	2017	42	58

HSIP-N063(801)

GENERAL NOTES

1. MAINTENANCE:

THE CONTRACTOR SHALL MAINTAIN ALL SIGNS AND DEVICES IN AN UPRIGHT POSITION. THE CONTRACTOR SHALL CLEAN OR REPLACE ANY DAMAGED OR ILLEGIBLE SIGN OR DEVICE AS DIRECTED BY THE ENGINEER.

2. EXISTING SIGNS:

IF EXISTING SIGNS THAT ARE TO REMAIN (WHETHER DENOTED ON THE PLANS OR NOT) INTERFERE WITH CONSTRUCTION WORK, THE CONTRACTOR SHALL REMOVE, STORE, AND RESET THE SIGNS. THIS SHALL BE SUBSIDIARY TO OTHER TRAFFIC CONTROL BID ITEMS. SIGNING DAMAGED BY THE CONTRACTOR SHALL BE REPLACED AT THE CONTRACTOR'S EXPENSE.

3. CONFLICTING SIGNS, SIGNS NOT IN USE, AND TRAFFIC SIGNALS:

SIGNS AND TRAFFIC SIGNALS THAT ARE IN CONFLICT WITH THE TRAFFIC CONTROL PLAN OR DO NOT APPLY TO THE TRAFFIC OPERATIONS SHALL BE IMMEDIATELY REMOVED, TURNED SO NOT VISIBLE TO TRAFFIC FROM ANY DIRECTION, OR COMPLETELY COVERED WITH ADEQUATE OPAQUE BREATHABLE MATERIAL. TAPE SHALL NOT BE APPLIED TO THE FACE OF THE SIGN.

4. PORTABLE AND POST MOUNTED SIGNS:

TEMPORARY TRAFFIC CONTROL SIGNS THAT ARE ANTICIPATED TO REMAIN IN PLACE FOR 3 DAYS OR LESS ARE CONSIDERED "PORTABLE." PORTABLE SIGNS SHALL BE MOUNTED ON AN APPROVED SUPPORT AT A MINIMUM HEIGHT OF 12" ABOVE THE TRAVELED WAY. TRAFFIC CONTROL SIGNS IN PLACE FOR OVER 3 DAYS ARE REQUIRED TO BE MOUNTED ON APPROVED POSTS. A MINIMUM OF 42" OF THE APPROVED POST MUST BE BELOW THE GROUND SURFACE WITH ADEQUATE BACKFILL AND COMPACTION. ALL POSTS AT MINIMUM SHALL EXTEND TO THE TOP EDGE OF THE SIGN AND NO GREATER THAN 6" ABOVE THE SIGN.

WHEN THE SIGN WIDTH IS EQUAL TO OR GREATER THAN 9', THREE OR MORE WOOD POSTS MAY BE USED WITH A MINIMUM OF 4' BETWEEN THE CENTERLINE OF EACH POST. ALL SIGNS LESS THAN 9' IN WIDTH SHALL USE A MAXIMUM OF TWO WOOD POSTS.

"ROLL-UP" SIGNS MAY BE USED FOR PORTABLE WARNING SIGNS. THEY MUST BE FLUORESCENT ORANGE ASTM TYPE IV SIGNS OF OPAQUE MATERIAL. MESH SIGNS ARE NOT ALLOWED.

5. SHEETING:

ALL ORANGE SIGNS SHALL HAVE FLUORESCENT ORANGE ASTM TYPE IV SHEETING. ALL OTHER SIGNS SHALL HAVE ASTM TYPE III SHEETING OF STANDARD COLORS.

6. SIGNS INVOLVING SPEEDS:

THE W3-5 (SPEED REDUCTION) SHOULD BE USED ONLY IF THE ENGINEER DETERMINES THAT A REDUCED SPEED IS REQUIRED ON THE PROJECT. THE KM4-20 (WORK ZONE) PLAQUE SHALL BE PLACED ABOVE ALL SPEED LIMIT SIGNS, (R2-1), EXISTING AND TEMPORARY. MOUNT THE WORK ZONE PLAQUE TO THE POST. DO NOT OVERLAP THE R2-1 AND KM4-20 SIGNS.

FOR SPEEDS OF 30 MPH OR LESS, THE W1-1(TURN) OR W1-3(REVERSE TURN) SHOULD BE USED. FOR SPEEDS OF 35 MPH OR MORE, THE W1-2(CURVE) OR W1-4(REVERSE CURVE) SHOULD BE USED. THE W13-1(MPH) IS TO BE ELIMINATED IF THE ADVISORY SPEED IS WITHIN 5 MPH OF THE SPEED LIMIT.

7. SIGNS CONTROLLING WORK ZONE:

THE KG20-2(END ROAD WORK) SHOULD BE PLACED 500' FROM THE END OF THE ACTUAL WORK SPACE, NOT NECESSARILY AT THE EXTREME LIMITS OF THE PROJECT. THE KG20-2 SHOULD BE MOUNTED ON TWO POSTS. THE KG20-2 MAY BE MOUNTED ON ONE POST IF IN URBAN AREAS WHERE UTILITIES ARE A PROBLEM AND WIND LOADS ARE NOT AN ISSUE.

WHERE TWO WORK ZONES ARE LESS THAN 1 MILE APART IN RURAL AREAS OR ¼ MILE APART IN URBAN AREAS, THE KG20-2(END ROAD WORK) FOR THE FIRST WORK ZONE AND THE W20-1(ROAD WORK) FOR THE SECOND WORK ZONE SHOULD BE ELIMINATED.

8. WARNING LIGHTS ON SIGNS:

TYPE "A" LOW INTENSITY WARNING LIGHTS SHOULD BE USED WITH ALL CONSTRUCTION ACTION WARNING SIGNS AND SHALL NOT BE USED ON SIGNS MOUNTED LESS THAN 5' HIGH ON TEMPORARY SUPPORTS. ON ALL OTHER CONSTRUCTION WARNING SIGNS, TYPE "A" LOW INTENSITY WARNING LIGHTS ARE TO BE USED AS DIRECTED BY THE ENGINEER.

TYPE "A" LOW INTENSITY WARNING LIGHTS SHALL BE MAINTAINED SO AS TO BE CAPABLE OF BEING VISIBLE ON A CLEAR NIGHT FROM A DISTANCE OF 3000 FT. IF A TYPE "A" LOW INTENSITY WARNING LIGHT HAS A SEPARATE BATTERY CASE, THE BATTERY CASE SHALL BE MOUNTED NO HIGHER THAN 12" ABOVE THE GROUND AND MOUNTED BEHIND THE SIGN POST. A TYPE "A" LOW INTENSITY WARNING LIGHT WHERE THE LENS AND BATTERY ARE ONE UNIT SHALL BE MOUNTED ON THE TEMPORARY SIGN POST NEAREST TO THE TRAVELED WAY. FLAGS SHALL NOT INTERFERE WITH THE VISABILITY OF THE TYPE "A" LOW INTENSITY WARNING LIGHT.

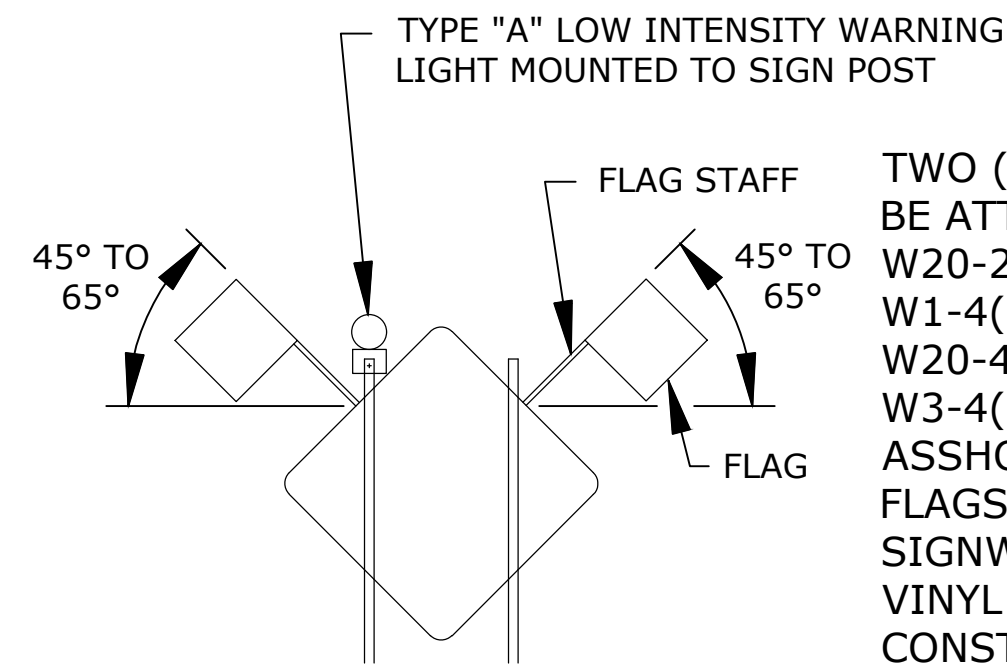

TWO (2) 18" x 18" FLUORESCENT RED-ORANGE FLAGS SHALL BE ATTACHED (IN THE POSITION SHOWN) ON THE W20-2(DETOUR),W1-1(TURN), W1-2(CURVE), W1-3(REVERSE TURN), W1-4(REVERSE CURVE), W3-3(SIGNAL AHEAD), W4-2(LANE REDUCTION), W20-4(ONELANE ROAD), W20-5(LANE CLOSED), W20-7A(FLAGGER), AND W3-4(BE PREPARED TO STOP) SIGNS AND ANY OTHER ACTION SIGNS AS SHOWN ON THE PLANS OR DIRECTED BY THE ENGINEER. THE FLAGS AND STAFFS ARE TO BE ATTACHED IN SUCH A MANNER THAT THE SIGN WILL NOT BE OBSCURED. THE FLAGS MAY BE EITHER A CLOTH OR VINYL MATERIAL. THE FLAGS SHALL BE SUBSIDIARY TO THE CONSTRUCTION SIGN BID ITEMS.

9. AUTOMATED FLAGGER ASSISTANCE DEVICE REQUIREMENTS:

STOP/SLOW AUTOMATED FLAGGER ASSISTANCE DEVICE:

THE AFAD'S STOP/SLOW SIGN SHALL HAVE AN OCTAGONAL SHAPE, SHALL BE FABRICATED OF RIGID MATERIAL, AND SHALL BE MOUNTED WITH THE BOTTOM OF THE SIGN A MINIMUM OF 6' ABOVE THE PAVEMENT ON AN APPROPRIATE SUPPORT. THE SIZE OF THE STOP/SLOW SIGN SHALL BE AT LEAST 30"X30" WITH LETTER AT LEAST 10" HIGH. THE BACKGROUND OF THE STOP FACE SHALL BE RED WITH WHITE LETTER AND BORDERS. THE BACKGROUND OF THE SLOW FACE SHALL BE DIAMOND SHAPED AND ORANGE WITH BLACK LETTERS AND BORDER. BOTH FACES OF THE STOP/SLOW SIGN SHALL BE RETROREFLECTORIZED. THE AFAD'S STOP/SLOW SIGN SHALL HAVE A MEANS TO POSITIVELY LOCK, ENGAGE, OR OTHERWISE MAINTAIN THE SIGN ASSEMBLY IN A STABLE CONDITION WHEN SET IN THE STOP OR SLOW POSITION.

THE AFAD'S STOP/SLOW SIGN SHALL BE SUPPLEMENTED WITH ACTIVE CONSPICUITY DEVICES BY INCORPORATING

1. WHITE OR RED FLASHING LIGHTS WITHIN THE STOP FACE AND WHITE OR YELLOW FLASHING LIGHTS WITHIN THE SLOW FACE.
2. A STOP BEACON MOUNTED NO MORE THAN 24" ABOVE THE STOP FACE AND A WARNING BEACON MOUNTED NO MORE THAN 24" ABOVE, BELOW, OR TO THE SIDE OF THE SLOW FACE. THE STOP BEACON SHALL NOT BE FLASHED OR ILLUMINATED WHEN THE SLOW FACE IS DISPLAYED, AND THE WARNING BEACON SHALL NOT BE FLASHED OR ILLUMINATED WHEN THE STOP FACE IS DISPLAYED.

RED/YELLOW LENS AUTOMATED FLAGGER ASSISTANCE DEVICE:

RED/YELLOW LENS AUTOMATED FLAGGER ASSISTANCE DEVICE SHALL ALTERNATELY DISPLAY A STEADILY ILLUMINATED CIRCULAR RED LENS AND A FLASHING CIRCULAR YELLOW LENS TO CONTROL TRAFFIC WITHOUT THE NEED FOR A FLAGGER IN THE IMMEDIATE VICINITY OF THE AFAD OR ON THE ROADWAY. THE STEADILY ILLUMINATED CIRCULAR YELLOW CHANGE INTERVAL SHOULD HAVE A DURATION OF AT LEAST 5 SECONDS, UNLESS A DIFFERENT DURATION, WITHIN THE RANGE OF DURATIONS IS JUSTIFIED BY AN ENGINEERING JUDGMENT. RED/YELLOW LENS AFAD'S SHALL HAVE AT LEAST ONE SET OF CIRCULAR RED AND CIRCULAR YELLOW LENSES THAT ARE 12" IN DIAMETER. CIRCULAR RED ON TOP AND CIRCULAR YELLOW BELOW, SHALL CONFORM TO AND BE OPERATED ACCORDING TO THE REQUIREMENTS OF THE LATEST VERSION OF THE MUTCD ADOPTED BY THE SECRETARY. IF THE SET OF LENSES IS POST-MOUNTED, THE BOTTOM OF THE HOUSING (INCLUDING BRACKETS) SHALL BE 7' ABOVE THE PAVEMENT. IF THE SET OF LENSES IS LOCATED OVER ANY PORTION OF THE HIGHWAY THAT CAN BE USED BY MOTOR VEHICLES, THE BOTTOM OF THE HOUSING (INCLUDING BRACKETS) SHALL BE AT LEAST 15' ABOVE THE PAVEMENT.

ALL AFAD'S SHALL INCLUDE A GATE ARM THAT DESCENDS TO A DOWN POSITION ACROSS THE APPROACH LANE OF TRAFFIC WHEN THE STOP FACE IS DISPLAYED AND THEN ASCENDS TO AN UPRIGHT POSITION WHEN THE SLOW FACE IS DISPLAYED. THE GATE ARM SHALL BE COVERED WITH ALTERNATING RED AND WHITE ASTM TYPE IV RETROREFLECTIVE STRIPES AT 6" INTERVALS MEASURED HORIZONTALLY. WHEN THE ARM IS IN THE DOWN POSITION BLOCKING THE APPROACH LANE THE MINIMUM VERTICAL ASPECT OF THE ARM AND SHEETING SHALL BE 2". THE STRIPES SHALL SLOPE DOWNWARD AT AN ANGLE OF 45 DEGREES FROM THE UPPER RIGHT TO THE LOWER LEFT ON THE SIDE OF THE ARM FACING STOPPED TRAFFIC, AND FROM THE UPPER LEFT TO THE LOWER RIGHT ON THE SIDE OF THE ARM FACING MOVING TRAFFIC IN THE ONCOMING DIRECTION. THE END OF THE ARM SHALL REACH AT LEAST TO THE CENTER OF THE LANE BEING CONTROLLED. ALL AFAD'S SHALL HAVE A PILOT LIGHT MOUNTED BEHIND EACH UNIT SO A SINGLE OPERATOR, OPERATING TWO UNITS, CAN VERIFY WHICH COLOR IS BEING DISPLAYED.

SIGN LAYOUT INFORMATION

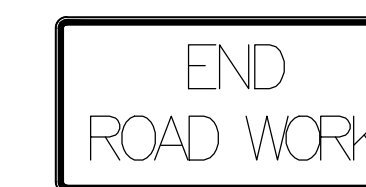

KG20-2
(BLACK ON ORANGE)

STD. SIZE
EXPWY/FREEWAY

6" C
48"x 24"

LETTER SIZES FOR BLACK ON
ORANGE "DESTINATION" SIGNS

STD. SIZE EXPWY/FREEWAY
6" C 10" D



KM4-20
(BLACK ON ORANGE)

STD. SIZE EXPWY/FREEWAY
3" C 6" C
24"x 6" 48"x 12"



W7-3a

NOTE:
TEXT DIMENSIONS ARE IN INCHES.
BORDER IS BLACK NON-REFLECTIVE.
SEE STD. TE730 OR TE731 FOR KG20-5 SIGN LAYOUT.



W8-11

COLORS:
LEGEND - BLACK (NON-REFLECTIVE)
BACKGROUND - ORANGE (REFLECTIVE)



W8-9a

COLORS:
LEGEND - BLACK (NON-REFLECTIVE)
BACKGROUND - ORANGE (REFLECTIVE)

THIS SIGN IS TO BE INSTALLED FOR CONDITIONS OF HEIGHT DIFFERENTIAL BETWEEN ADJACENT LANES OVER ONE (1) INCH. IT IS TO BE PLACED AT EACH INTERSECTING CROSSROAD, MAJOR TRAFFIC GENERATOR, OR AT APPROXIMATELY ONE-HALF (1/2) MILE INTERVALS. THE SIGNS ARE TO BE REMOVED OR COVERED WHEN NOT APPLICABLE.

MINIMUM ADVANCE WARNING SIGN SPACING (IN FEET):

	A	B	C
URBAN (40 MPH OR LOWER)	100	100	100
URBAN (45 MPH OR HIGHER)	350	350	350
RURAL (55 MPH OR LOWER)	500	500	500
RURAL (60 MPH OR HIGHER)	750	750	750
EXPRESSWAY/FREEWAY	1000	1500	2640

THE MINIMUM SPACING BETWEEN SIGNS SHALL BE NO LESS THAN 100', UNLESS DIRECTED BY THE ENGINEER.

THE SPACING BETWEEN ANY SIGNS MAY BE INCREASED BEYOND THE MINIMUM VALUES IN THE TABLE ABOVE AS APPROVED BY THE ENGINEER IN ORDER TO MAXIMIZE VISIBILITY.

3	10/4/11	Modified Note 3	J.A.M.	K.P.
2	2/24/10	Modified AFAD Note	J.A.M.	A.A.A.
1	10/28/09	Modified AFAD Note	J.A.M.	A.A.A.
NO.	DATE	REVISIONS	BY	APP'D

KANSAS DEPARTMENT OF TRANSPORTATION

TRAFFIC CONTROL SIGNS

TE710	42 of 58	03/2017
FHWA APPROVAL	10/4/11	APP'D Kristina Pyle
DESIGNED	B.A.H. DETAILED	B.A.H. QUANTITIES
DESIGN CK.	DETAIL CK.	QUAN. CK. TRACE CK.