

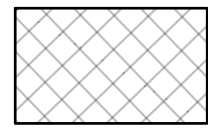



LEGEND

-  Pavement Removal
-  Sidewalk Removal
-  Curb & Gutter Removal
-  Brick Paver Removal
-  2" Mill & Overlay
-  Tree Removal

Note:  
 (XXX) For control and coordinate data, See Sheet 3

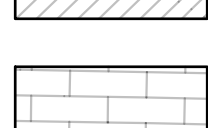
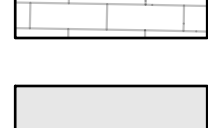
Contractor shall see streetscape plans for all items of construction beyond the back of curb, See Sheets 9-15

Contractor shall see sidewalk quadrant detail sheets for more information on the construction of the corners, See Sheets 18-31

All other material and labor needed to connect the existing storm sewer to the proposed storm sewer or inlets shall be considered **SUBSIDIARY** to the bid item. "Connect to Existing Structures".

Contractor shall allow full access to the existing parking garage on the southeast corner of 1st Street and Mead Street throughout the duration of construction.

The Contractor shall contact Scott Wadle, Senior Management Analyst for the City of Wichita at 316-352-4855, prior to beginning construction of the north half of 1st Street to coordinate the relocation of the existing Bike Share ITC bike rack located on the south side of the hotel at approx. Sta. 19+80.50, 36.90' Lt.

Any storm sewer adjacent to the curb & gutter or under any proposed pavement on mainline, side roads, or entrances shall be backfilled in accordance with the City of Wichita Specifications unless otherwise noted on the plans or by the Engineer.

The sand or grout used to fill the abandoned storm sewer shall be considered **SUBSIDIARY** to the bid item. "Pipe, Abandon in Place".

All other material and labor needed to install & connect the 6" DI CL roof drain to the building shall be considered **SUBSIDIARY** to the bid item. "Pipe, 6" DI CL".

BACK OF CURB LOCATION & ELEVATIONS				
STATION	OFFSET	ELEVATION	DESCRIPTION	
7	17+02.63	22.92' Rt.	1298.26	Curb & Gutter Corner Point
8	19+81.07	24.06' Rt.	1296.72	Curb & Gutter Corner Point
9	20+31.07	23.75' Rt.	1296.76	Curb & Gutter High Point
10	20+82.08	23.39' Rt.	1296.68	Curb & Gutter Corner Point
11	21+57.57	22.66' Rt.	1296.90	Curb & Gutter Corner Point

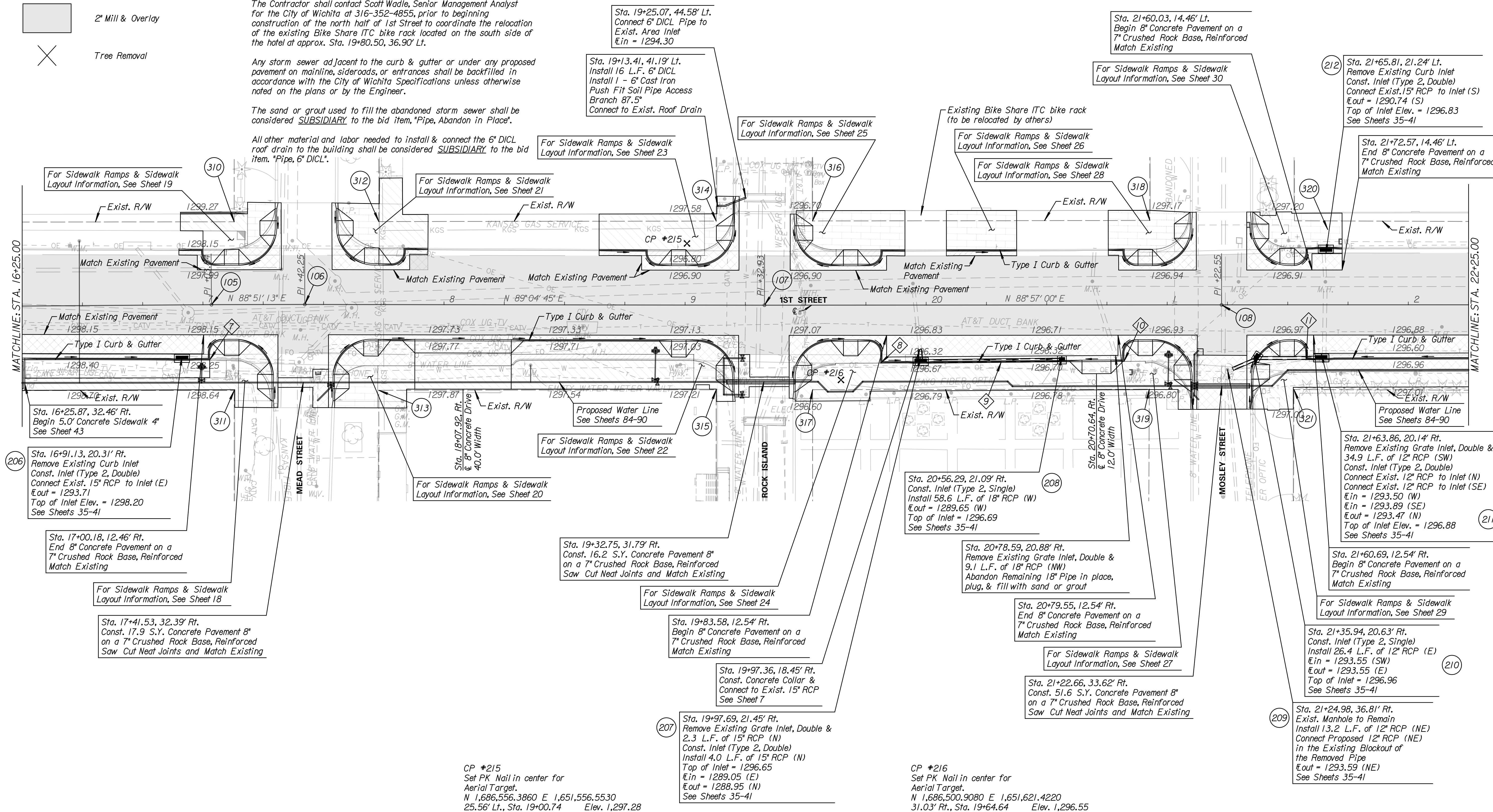
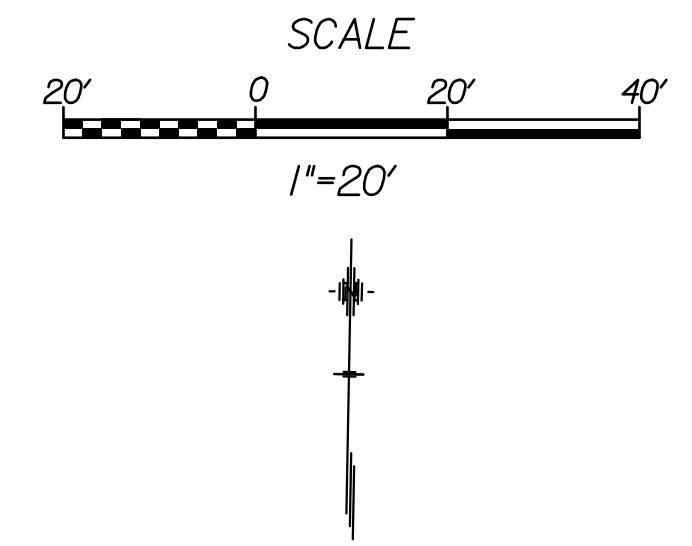

CP #215  
 Set PK Nail in center for  
 Aerial Target.  
 N 1,686,556.3860 E 1,651,556.5530  
 25.56' Lt., Sta. 19+00.74 Elev. 1,297.28

CP #216  
 Set PK Nail in center for  
 Aerial Target.  
 N 1,686,500.9080 E 1,651,621.4220  
 31.03' Rt., Sta. 19+64.64 Elev. 1,296.55

**Tran Systems**  
 245 NORTH WACO  
 SUITE 222  
 WICHITA, KANSAS 67202  
 PHONE: 316-303-3000  
 FAX: 316-303-0156

CONSULTANTS:  
**LK ARCHITECTURE, INC.**  
 345 RIVERVIEW  
 SUITE 200  
 WICHITA, KANSAS 67208  
 PHONE: 316-268-0230

1ST STREET IMPROVEMENTS  
 SANTA FE TO WASHINGTON IN OLD TOWN  
 WICHITA, KANSAS  

REVISIONS:	DESCRIPTION	DATE	MARK

PROJ NO: 472-85285  
 SCALE: 1"=20'  
 DATE: 7/5/2017  
 DESIGNED BY: TAU  
 DRAWN BY: TAU  
 CHECKED BY: MDB

SHEET TITLE:  
**1ST STREET IMPROVEMENTS**

SHEET NO.  
 6  
 SHEET 6 OF 90