

LEGEND



Proposed Sign



Existing Sign to Remain



Existing Sign to be Removed/Relocated



Single Post Sign

Note:
All pavement markings shall be epoxy. Pavement markings shall be installed per manufacturer's recommendations. Full traffic may not be restored (and substantial project completion achieved) until all pavement markings are in place. Should construction timing be such that restoration of traffic becomes necessary during temperatures prohibiting the installation of epoxy markings, the Contractor shall install and maintain temporary markings until such time that epoxy markings may be properly install. Except for the material requirement, temporary pavement markings shall be placed equivalent, in every manner (i.e. dimension, frequency, spacing, etc.), to the permanent marking layout. The cost for temporary pavement markings will not be paid for directly, but shall be considered SUBSIDIARY to the bid item "Pavement Marking".

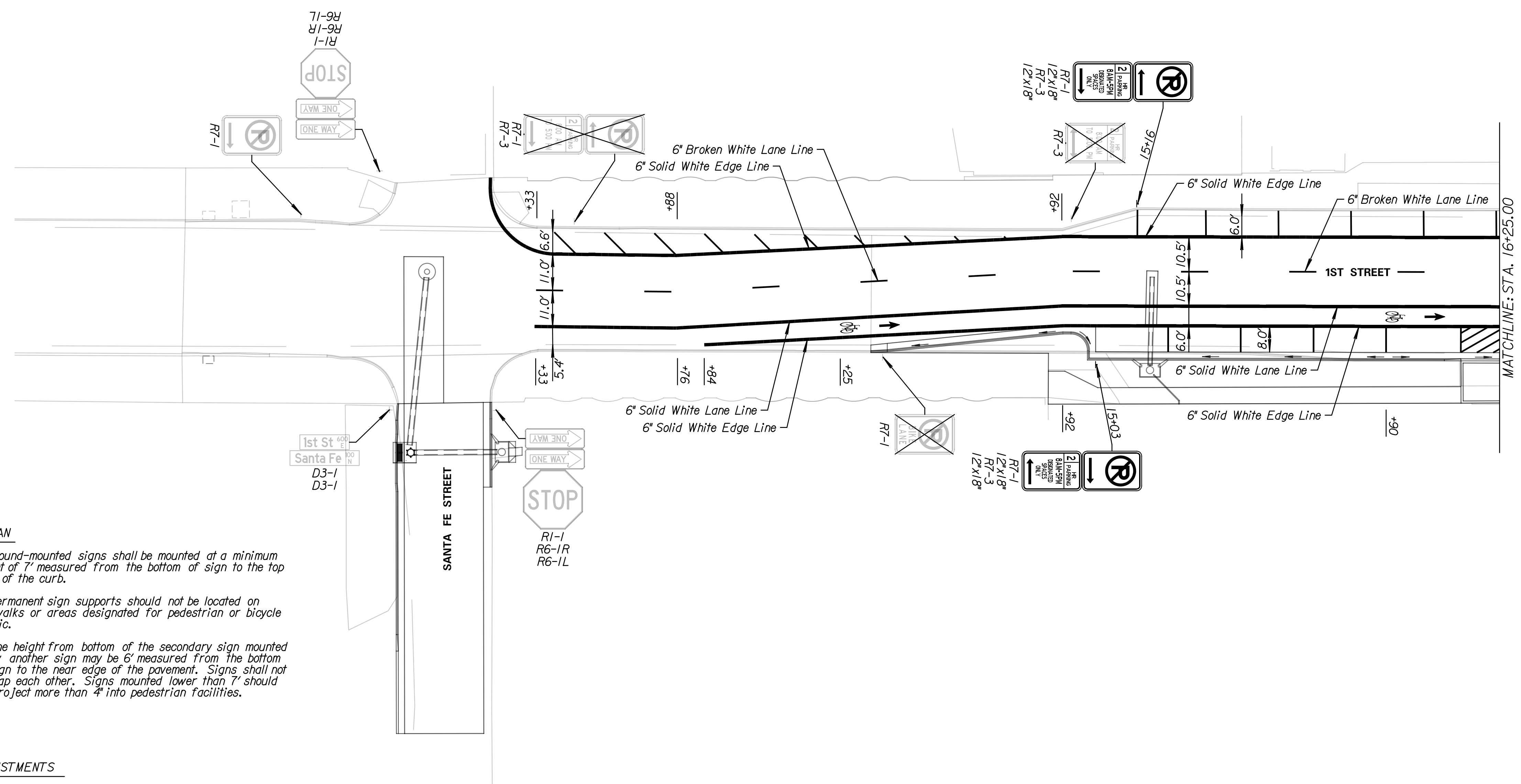
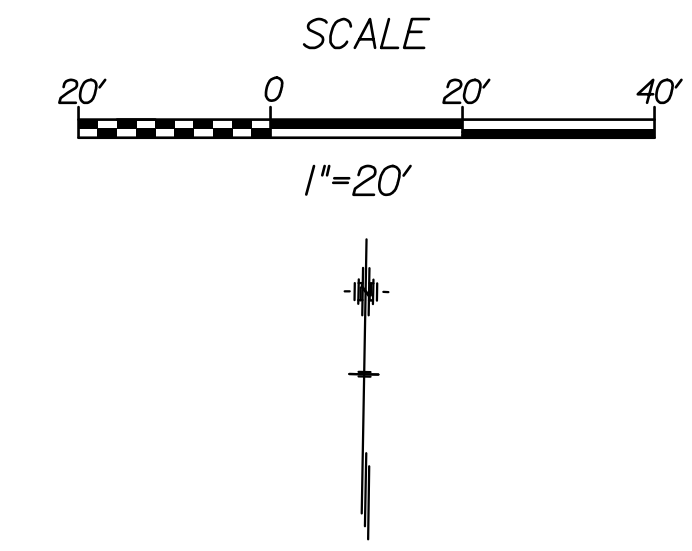

URBAN

1. Ground-mounted signs shall be mounted at a minimum height of 7' measured from the bottom of sign to the top edge of the curb.
2. Permanent sign supports should not be located on sidewalks or areas designated for pedestrian or bicycle traffic.
3. The height from bottom of the secondary sign mounted below another sign may be 6' measured from the bottom of sign to the near edge of the pavement. Signs shall not overlap each other. Signs mounted lower than 7' should not project more than 4" into pedestrian facilities.

ADJUSTMENTS

Signs may be moved laterally or longitudinally if it will improve the visibility of the sign or other signs and if it will protect the sign more.

*If the edge of a sign placed adjacent to the 10' sidewalk is at least 2'-0" from the edge of the sidewalk then the bottom of the sign may be placed 7'-0" higher than the edge of the sidewalk. If the edge of a sign placed adjacent to the 10' sidewalk is less than 2'-0" from the edge of the sidewalk then the bottom of the sign must be a minimum of 8'-6" higher than the edge of the sidewalk.

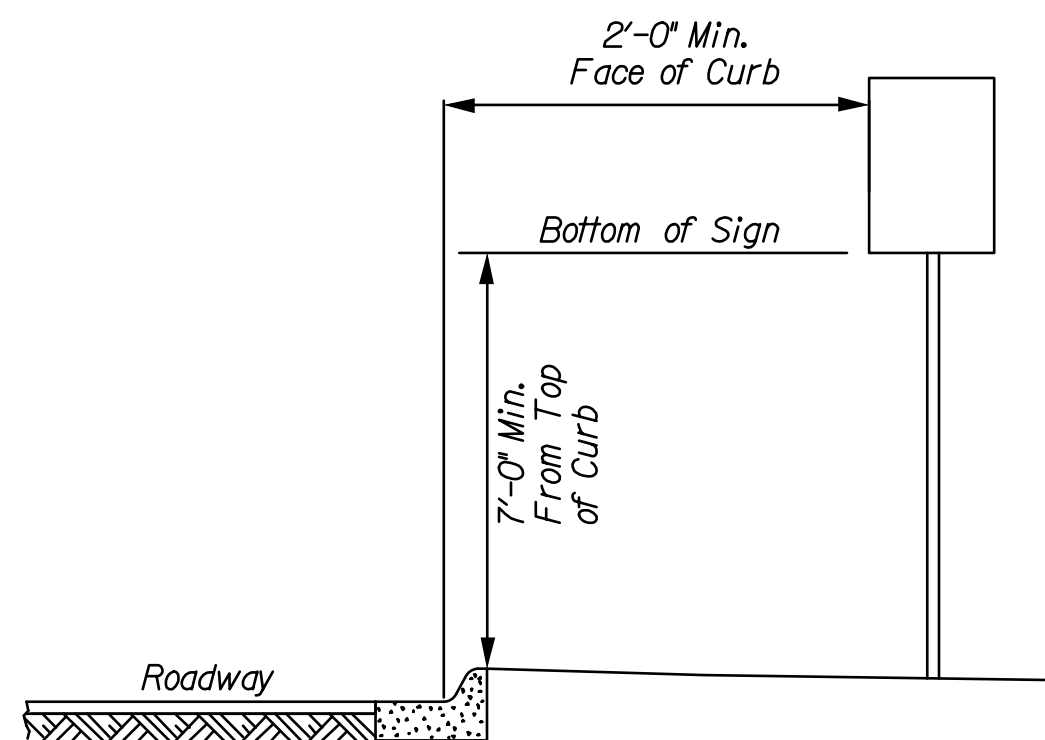

Sign Placement on Roadway Shoulder

Tran Systems
245 NORTH WACO
SUITE 222
WICHITA, KANSAS 67202
PHONE: 316-303-3000
FAX: 316-303-0166

CONSULTANTS:
LK ARCHITECTURE, INC.
345 RIVERVIEW
SUITE 200
WICHITA, KANSAS 67208
PHONE: 316-268-0230

1ST STREET IMPROVEMENTS
SANTA FE TO WASHINGTON IN OLD TOWN
WICHITA, KANSAS
WICHITA CITY OF

REVISIONS:	MARK	DATE	DESCRIPTION

PROJ NO: 472-85285
SCALE: 1"=20'
DATE: 7/5/2017
DESIGNED BY: TAU
DRAWN BY: TAU
CHECKED BY: MDB

SHEET TITLE:
PAVMENT MARKING & SIGNING
STA. 14+34.58 TO STA. 16+25.00

SHEET NO.
66
SHEET 66 OF 90