

WATER VALVE BOX ELEVATIONS			
STREET	STATION	OFFSET	PROPOSED ELEVATION
RUTGERS COURT	132+57.5	39.7' RL	169.5

PROJECT NO.	472-83256	SHEET NO.	10	TOTAL SHEETS	54
-------------	-----------	-----------	----	--------------	----

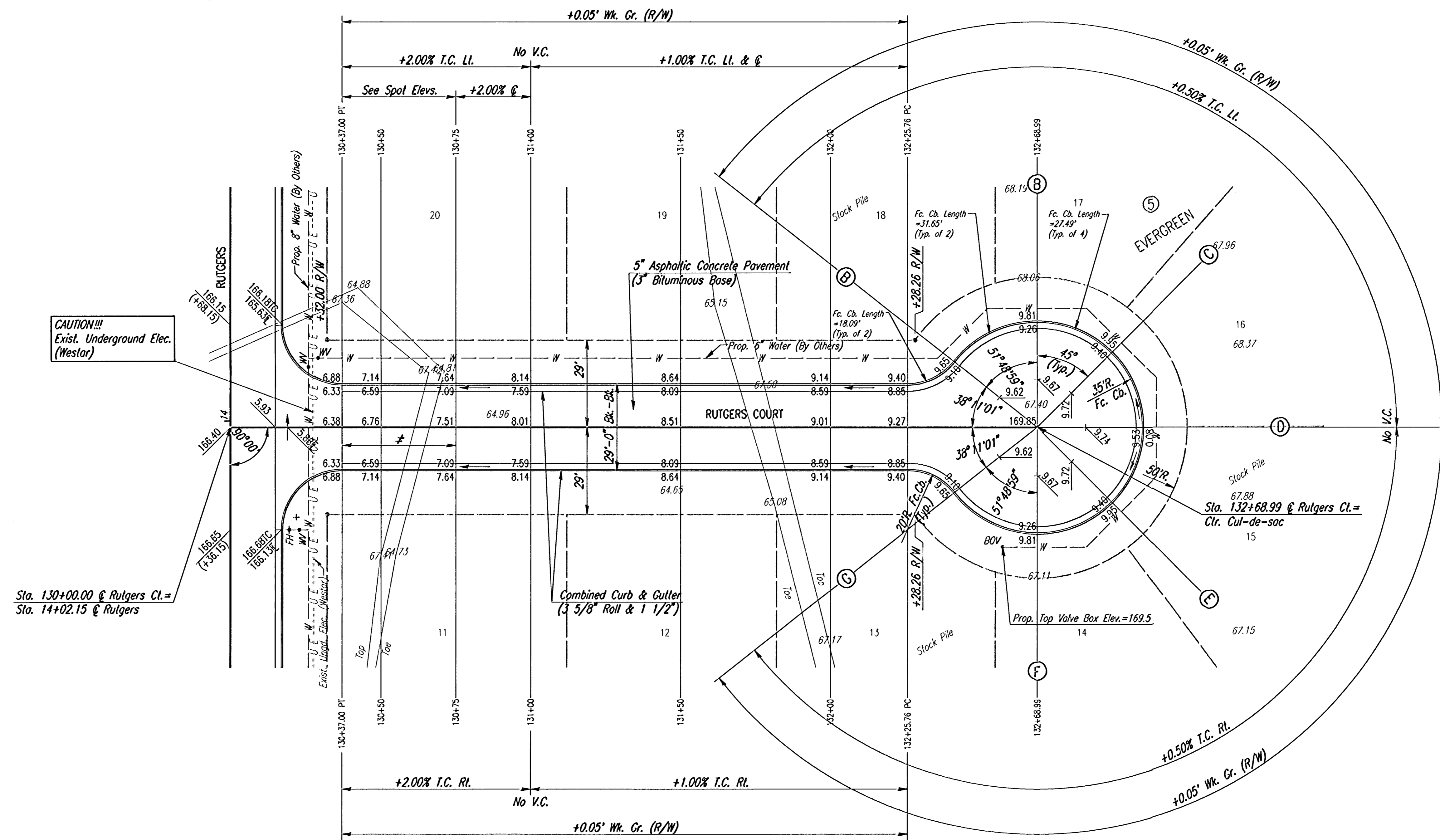
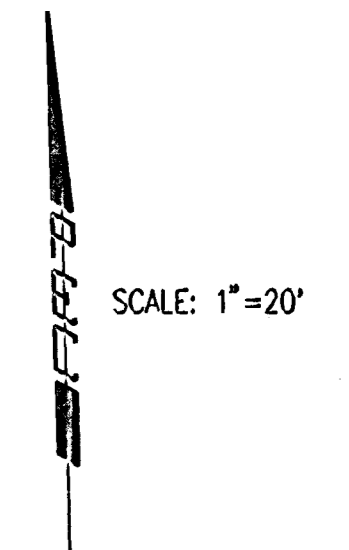

CAUTION!!!
Exist. Underground Elec.
(Westar)

Sta. 130+00.00 @ Rutgers Ct. =
Sta. 14+02.15 @ Rutgers

≠ TRANSITION FROM NO CROWN
TO FULL CROWN (3/8"/FT.).

**NOTE: THIS STREET TO BE CONSTRUCTED WITH
ROLL-TYPE CURB. TOP OF CURB ELEVATIONS
GIVEN ARE FOR FULL HEIGHT CURB.**

No.	Revisions	By	Date

EVERGREEN-PHASE 4
CITY OF WICHITA, KANSAS
RUTGERS COURT
STA. 130+00 TO STA. 132+68.99

Professional Engineering Consultants, P.A.
303 S. TOPEKA • WICHITA, KANSAS 67202
316-262-2691 • FAX 316-262-3003

Designed by	BER	Checked by	
Drawn by	BJS	Date	AUG. 2002
		Job No.	02397

I: 2002/02/23/ST-30-33.dgn
 Date Plotted: Oct. 31, 2002
 Deliver to: Bill Seaton