

LEGEND



New Sign



Existing Sign to be Removed



Single Post Sign

Note:

All striping shall be in accordance with the City of Wichita specifications. Striping located on the concrete pavement shall be epoxy while any striping located on the asphalt pavement shall be thermoplastic

All existing pavement parking on US-54 shall be removed back to the proposed 24" White Stop Line.

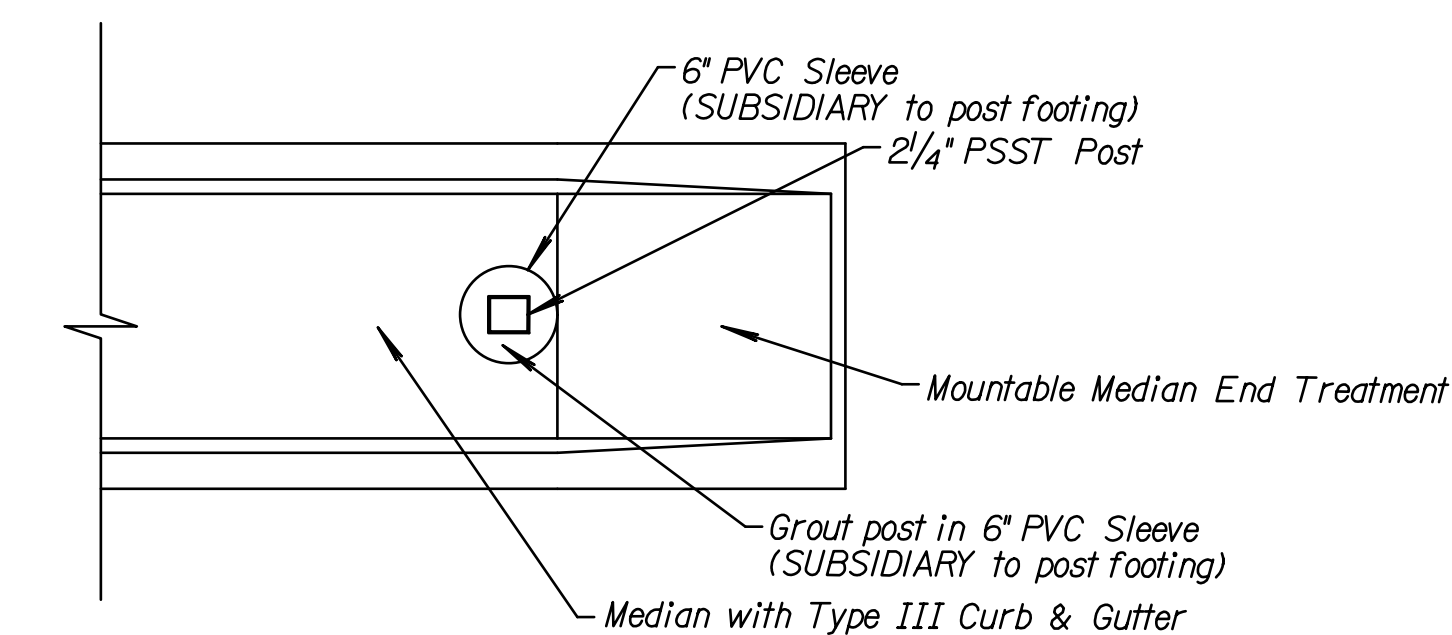
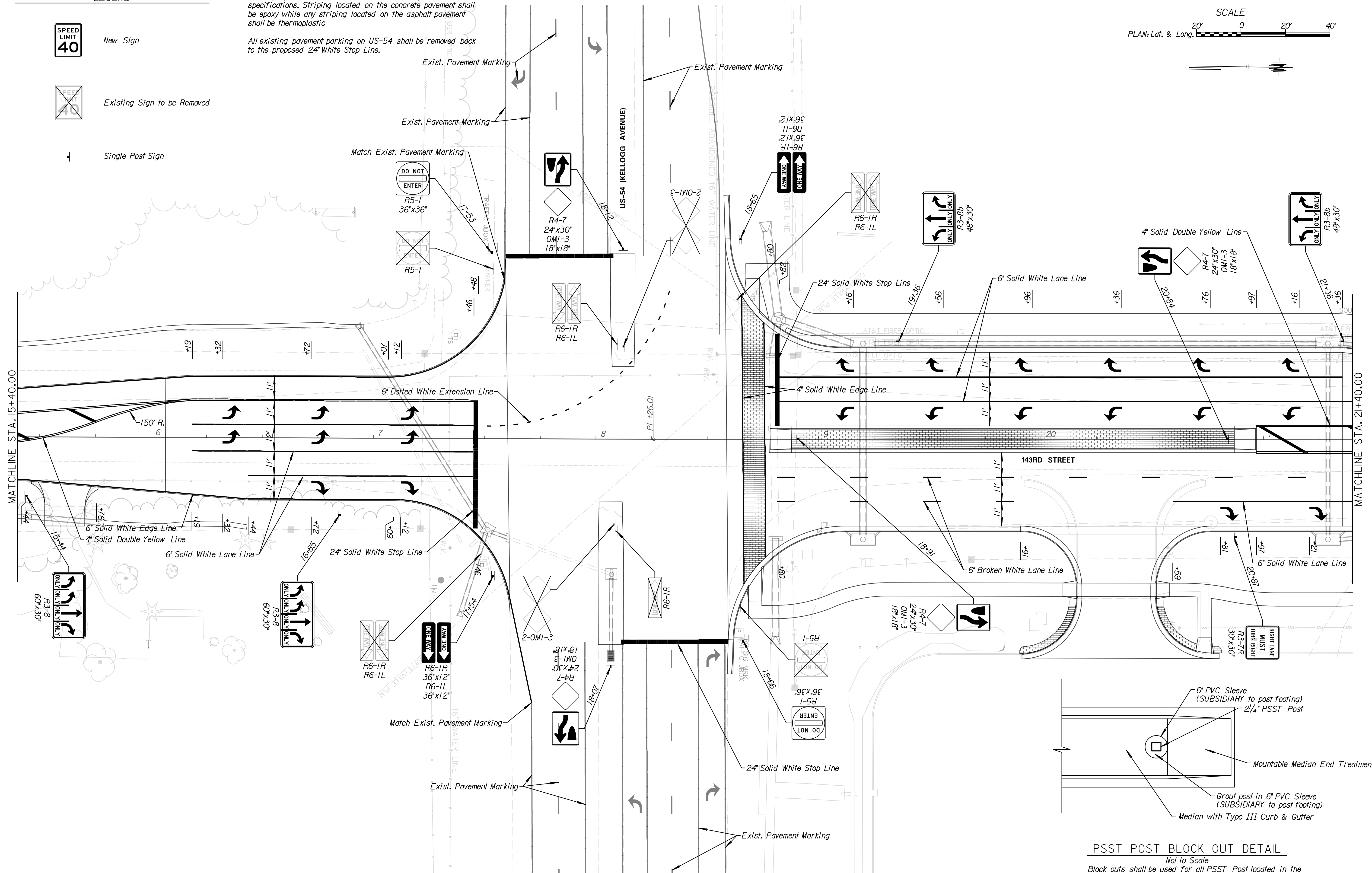
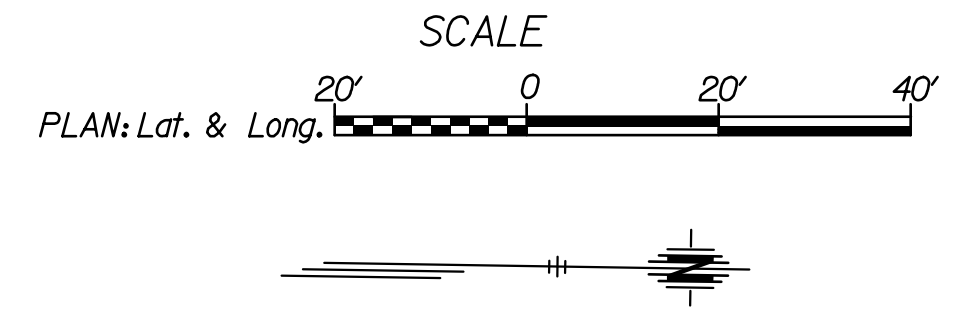

PSST POST BLOCK OUT DETAIL  
 Not to Scale  
 Block outs shall be used for all PSST Post located in the medians. The 6" pvc sleeves shall be installed prior to the placement of the Flowable Fill and 4" Concrete Pavement within the medians.

**Tran Systems**  
 245 NORTH WACO  
 SUITE 222  
 WICHITA, KANSAS 67202  
 PHONE: 316-303-3000  
 FAX: 316-462-5629

CONSULTANTS:

143RD STREET IMPROVEMENTS  
 WICHITA, KANSAS

REVISIONS:	MARK	DATE	DESCRIPTION

PROJ NO: 87 N-0614-01  
 SCALE: 1" = 20'  
 DATE: 5/26/2017  
 DESIGNED BY: TAU  
 DRAWN BY: TAU  
 CHECKED BY: MDB

SHEET TITLE:  
**PAVEMENT MARKING & SIGNING**  
 STA. 15+40.00 TO STA. 21+40.00

SHEET NO.  
**140**

SHEET 140 OF 236

5/26/2017 11:17:02 AM c:\tran\systems\paw\_bocall\transys\paw\14ummed\0228400-C-PMK-M01-102.dgn