

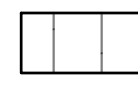

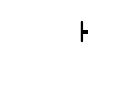



LEGEND

-  Phase 3
-  Single Post/Skid Mounted Sign
-  Channelizer
-  Tubular Marker (36")
-  Type III Barricade
-  Type III Barricade w/ Sign
-  Portable Changeable Message Board
-  Pavement Marking Removal

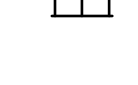
Phase 3

Phase 3 work shall construct the next 12.0' of proposed roadway and up to the high edge of the median curb at the intersection of 143rd Street and US-54 (Kellogg Avenue). Two-way traffic shall be carried through the construction area, the south bound traffic shall be on the newly constructed southbound lanes of 143rd Street and the north bound traffic will be on the existing alignment while utilizing temporary surfacing. Temporary traffic signal heads shall be adjusted to match the new phasing layout at the intersection of 143rd Street and US-54 (Kellogg Avenue) and all movements at the intersection shall not be restricted. Major items of work shall include storm sewer, asphalt and concrete pavement, curb & gutter, sidewalk construction, grading, seeding, pavement marking, and permanent traffic and pedestrian signal improvements.

Note:
 KI-104a & KI-105a shall be placed in the appropriate positions. See Sheet 133 (TE 710) for more details.

For the temporary traffic signal layout and details for Phase 3 See Sheets 125 & 129

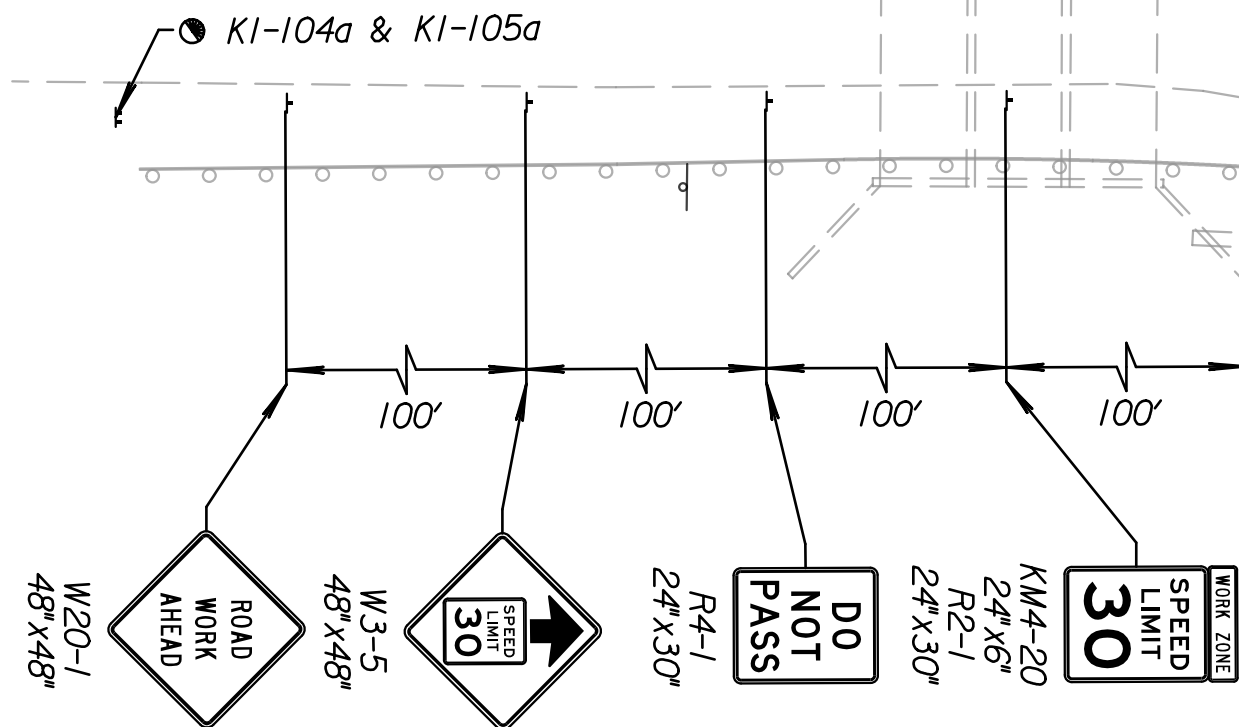
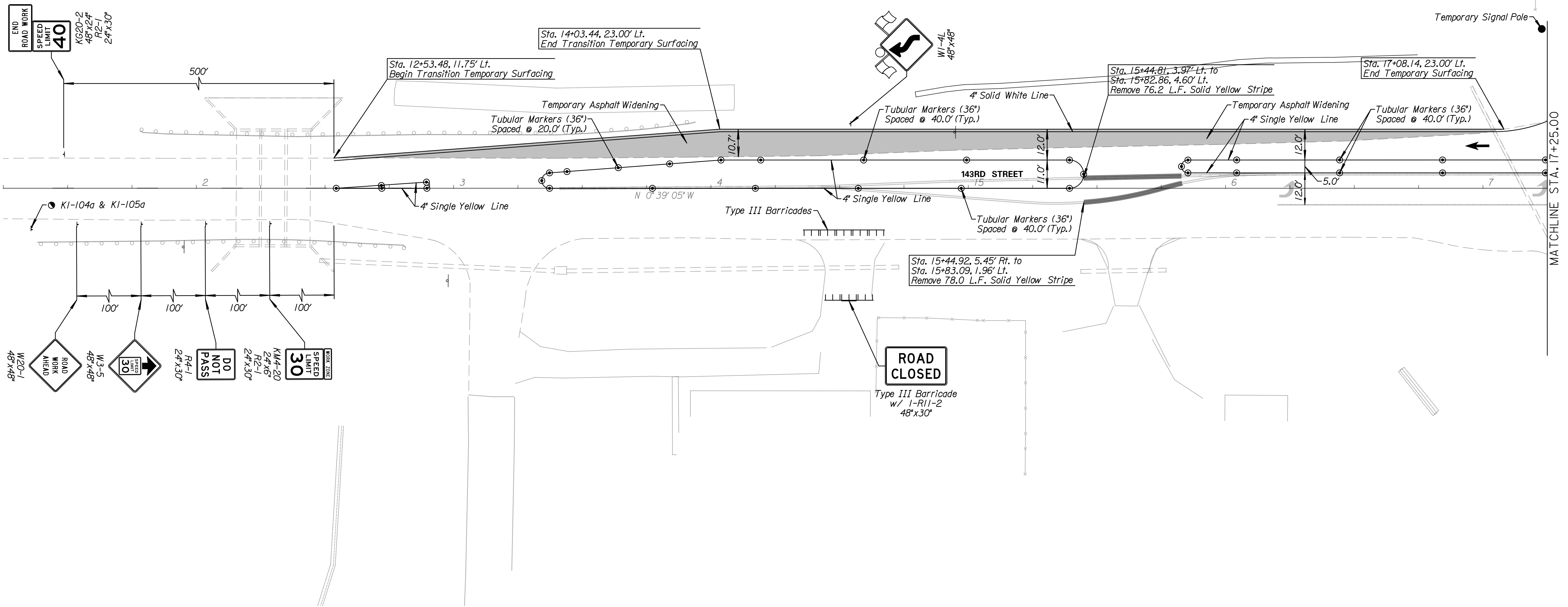
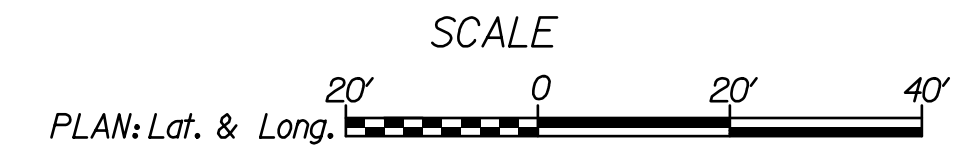

Tran Systems
 245 NORTH WACO
 SUITE 222
 WICHITA, KANSAS 67202
 PHONE: 316-303-3000
 FAX: 316-462-5629

CONSULTANTS:

143RD STREET IMPROVEMENTS
 WICHITA, KANSAS

| REVISIONS: | MARK | DATE | DESCRIPTION |
|------------|------|------|-------------|
| | | | |
| | | | |
| | | | |
| | | | |

PROJ NO: 87 N-0614-01
 SCALE: 1"=20'
 DATE: 5/26/2017
 DESIGNED BY: TAU
 DRAWN BY: TAU
 CHECKED BY: MDB

SHEET TITLE:
143RD STREET IMPROVEMENTS TRAFFIC CONTROL PHASE 3

SHEET NO.
93

SHEET 93 OF 236

11:12:15 AM c:\transystems\paw_b\alltransystems\paw\taummed\0228400C-CPP-M01-601.DGN