

ELEVATION AT HUBGUARD
(1 Required)

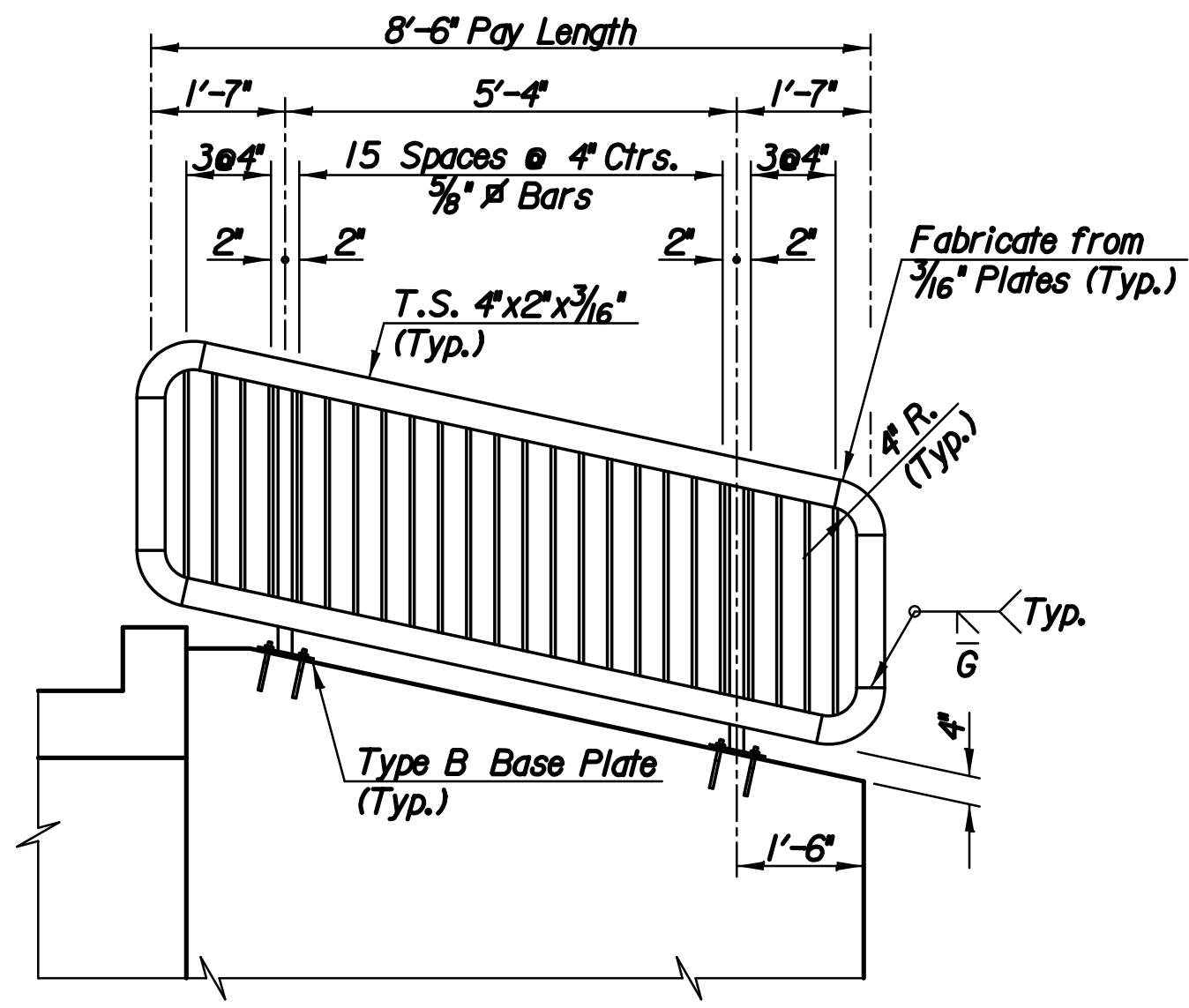

ELEVATION AT WINGWALL
(2 Required)

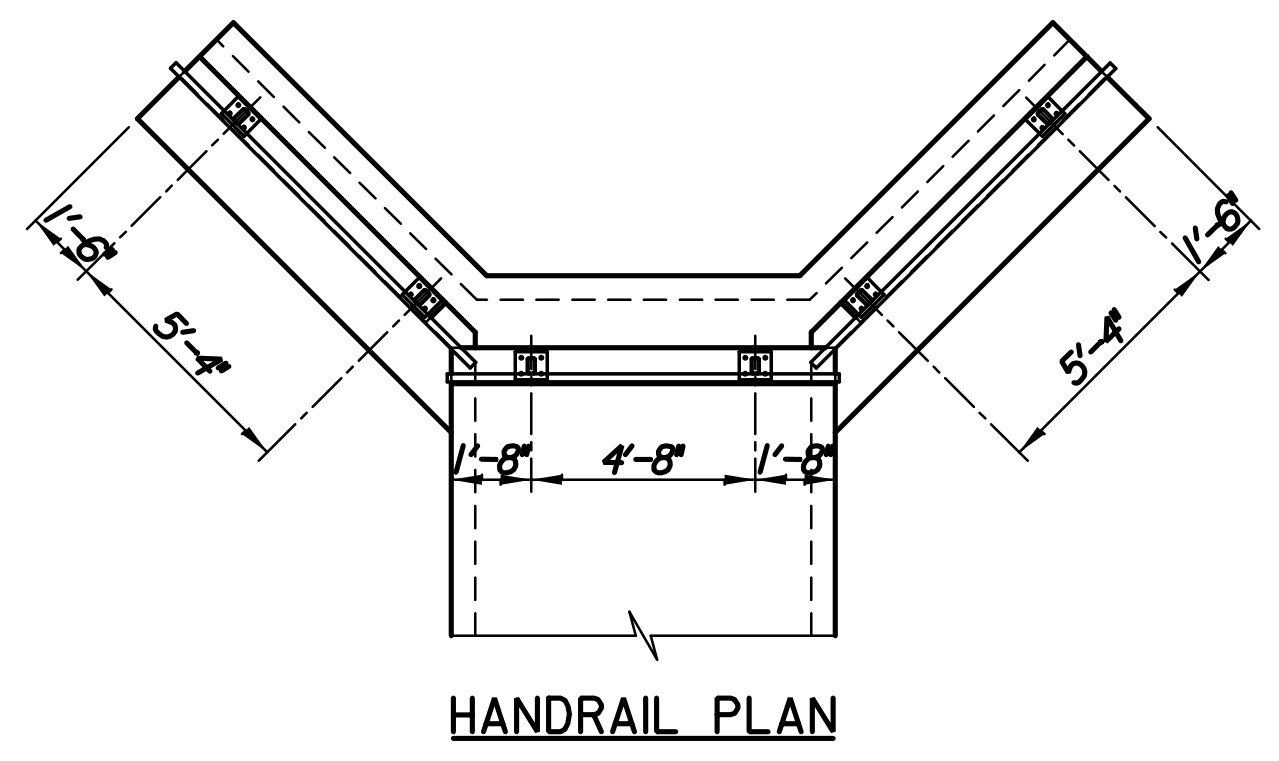

HANDRAIL PLAN

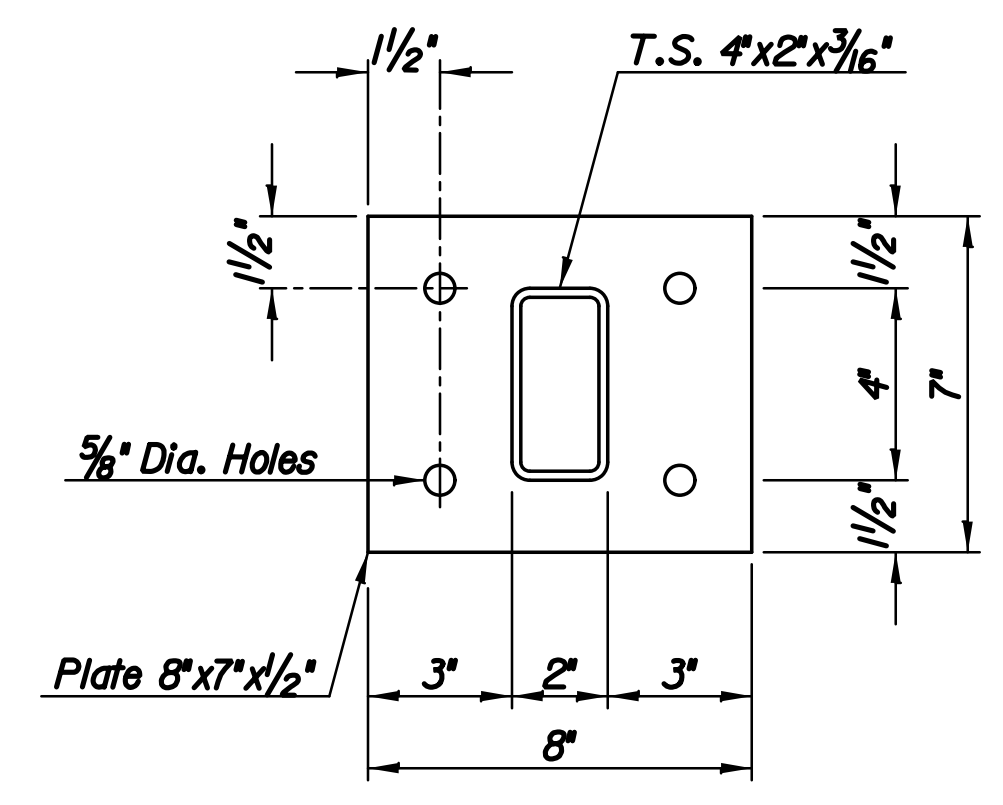

TYPE A BASE PLATE
(2 Required)

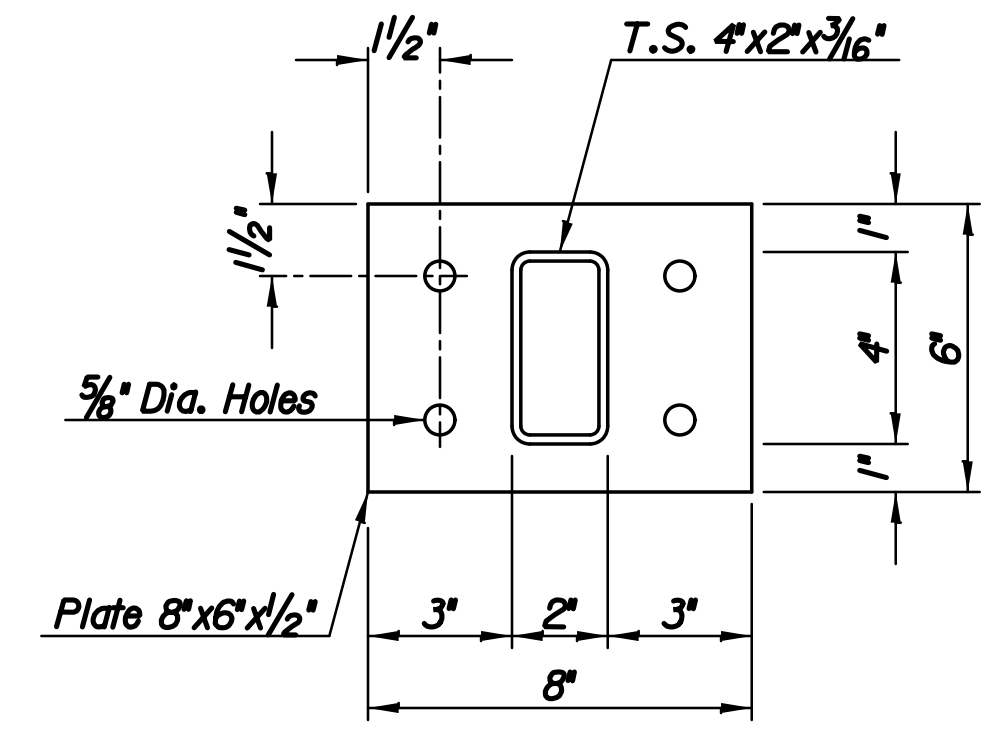

TYPE B BASE PLATE
(4 Required)

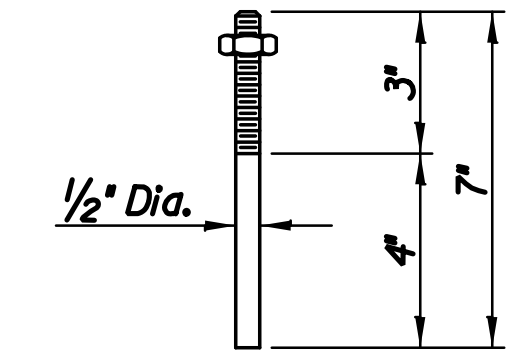

Galvanized (ASTM A153)
(May substitute expandable anchor bolts
when approved by the Engineer)

ANCHOR BOLT

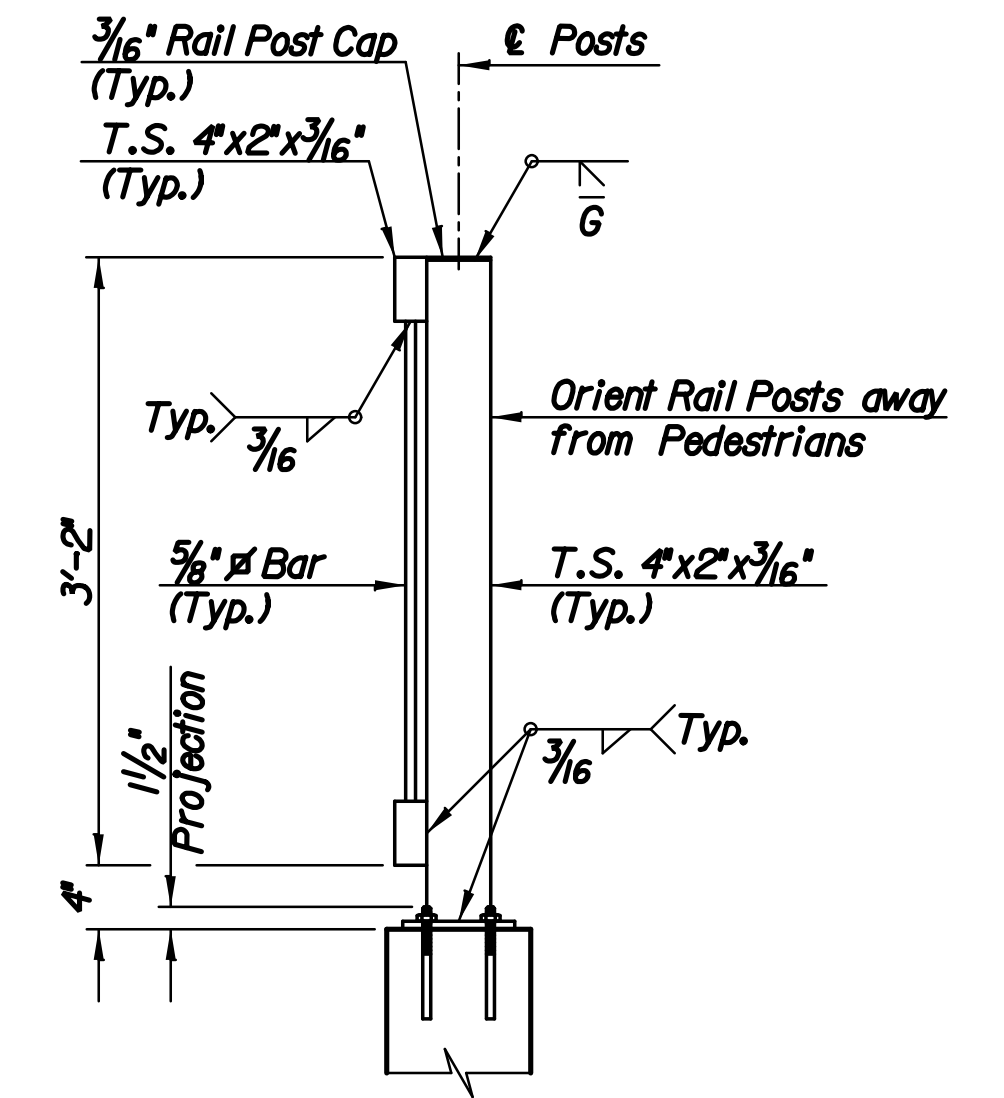

SECTION A-A
Center Posts on Hubguard or Wingwall

GENERAL NOTES

- The horizontal members of the Rail and Posts shall be hollow structural tubing. All structural steel tubing shall comply to A.S.T.M. designation A36 or A500 Grade B respectively.
- Rail shall be fabricated in lengths as shown from joint to joint and joint to end.
- Post and Bars shall be set vertical and shimmed if required.
- Prior to painting abrasive blast to commercial finish SSPC-SP6 to obtain a surface profile of 1 1/2 Mils. The shop and field coats applied to structural steel shall conform to an inorganic Zinc Primer with water-borne Acrylic finish coat. (The finish coat shall match Carboline #C900, Ebony Black). Provide a color sample to the Engineer with shop drawing submittal.
- Material and construction shall conform to the structural welding code A.W.S. D1.1-01.
- Shop details must be submitted and approved by the Engineer.
- All work associated with furnishing and installing Handrail shall be paid for as "Handrail (Steel), Pedestrian (3'-6") (Sta. 113+03)".

SUMMARY OF QUANTITIES

Item	Quantity	Unit
Handrail (Steel), Pedestrian (3'-6") (Sta. 113+03)	24.8	L.F.

No.	Revision	By	Date
TYLER ROAD BETWEEN MAPLE AND CENTRAL PAVING AND INCIDENTAL IMPROVEMENTS PEDESTRIAN HANDRAIL FOR 7' x 3' R.C.B. GARY JANZEN, P.E. - CITY ENGINEER CITY OF WICHITA PROJECT NO. 472-85282			
		PROFESSIONAL ENGINEERING CONSULTANTS, P.A. 303 SOUTH TOPEKA WICHITA, KS 67202 316-262-2691 www.pec1.com	
Designed by	M.S.N.	Job No.	31-15956-000
Drawn by	W.L.L.	Date	JULY 2017

Plotted By : wll 5-13-2017
 Drawing Name : U:\Wichita-Civil\2015\15956\000\Trans\Bridg\Dgn_Pro\lect\Handrail\Tx3 RCB.dgn