

- LEGEND**
- TOP OF FINISH GRADE
 - TOP OF WALL
 - FLOWLINE
 - MATCH EXISTING ELEVATION
 - PROPOSED CONTOUR
 - EXISTING CONTOUR
 - CONTOUR INTERVAL: 1 FOOT

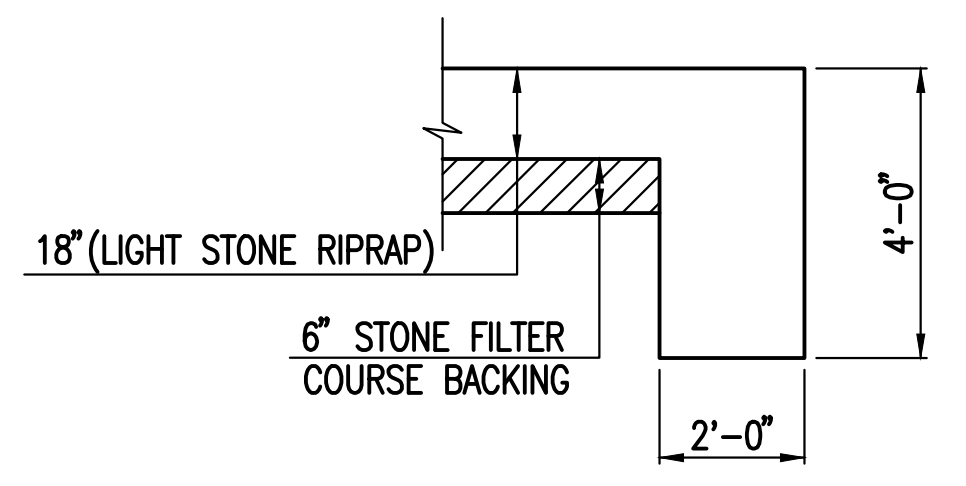
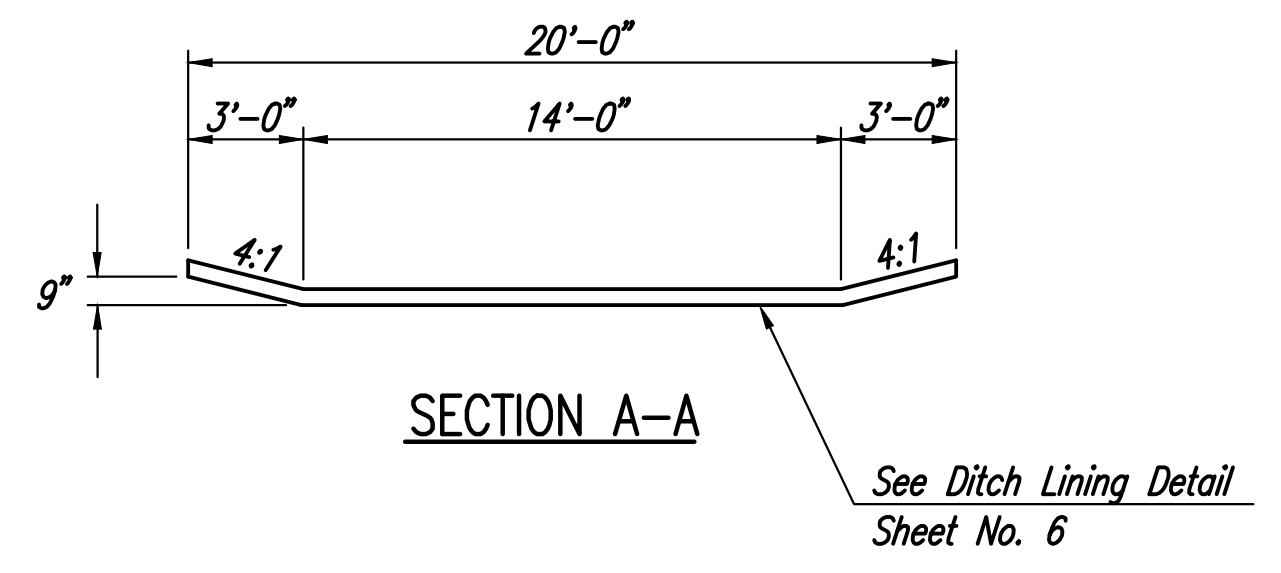

TYPICAL SECTION THRU TOEWALL
NO SCALE

- NOTES**
1. ALL RIPRAP FOR THIS PROJECT SHALL BE NATURAL STONE. NEITHER BROKEN CONCRETE, FABRIC ENVELOPE, NOR PREMIXED DRY PACKAGED CONCRETE BAG ALTERNATES WILL BE ALLOWED, UNLESS INDICATED OTHERWISE.
 2. TOEWALLS SHALL BE INSTALLED ALONG ALL UNPROTECTED EDGES OF STONE RIPRAP.
 3. GROUTING OF THE SURFACE OF THE RIPRAP SHALL NOT BE PERFORMED, UNLESS INDICATED OTHERWISE. GROUTING OF THE TOEWALLS SHALL BE PERFORMED PER CITY SPECIFICATIONS.

LIGHT STONE RIPRAP DETAILS

RIPRAP PLAN
(STORM WATER DRAIN)

COORDINATE LIST-CONC. WEIR		
POINT	NORTH	EAST
6200	1,698,426.1833	1,688,465.7961
6201	1,698,476.1617	1,688,467.2666

(6200) = COORDINATE POINT NO.

COORDINATE LIST		
POINT	NORTH	EAST
6100	1,698,476.5440	1,688,454.2721
6101	1,698,475.7794	1,688,480.2609
6102	1,698,460.7859	1,688,479.8198
6103	1,698,460.1095	1,688,502.8098
6104	1,698,459.5327	1,688,522.4143
6105	1,698,459.1932	1,688,533.9508
6106	1,698,439.2019	1,688,533.3626
6107	1,698,439.5413	1,688,521.8261
6108	1,698,440.1181	1,688,502.2217
6109	1,698,440.7945	1,688,479.2316
6110	1,698,425.8010	1,688,478.7904
6111	1,698,426.5657	1,688,452.8017

(6100) = COORDINATE POINT NO.

Sowed 09-28-2017 9:30:36 AM by GAGE SCHEER
 Plot Scale 1:1 10-02-2017 9:29:19 AM by GAGE SCHEER
 U:\Wichita-Civil\2014\14472\Drawings\14472-002-C05-RIPRAP AND MISCELLANEOUS DETAILS

JOSHUA GOLK
LICENSED
24136
10/02/2017
KANSAS
PROFESSIONAL ENGINEER

CROSS POINTE 2ND STORM WATER DRAIN NO. 399	
RIPRAP AND MISCELLANEOUS DETAILS	
GARY JANZEN, P.E. - CITY ENGINEER CITY OF WICHITA PROJECT NO. 468-85013	
PEC PROFESSIONAL ENGINEERING CONSULTANTS, P.A. 303 SOUTH TOPEKA WICHITA, KS 67202 316-262-2691 www.pec1.com	
Designed by JAG Drawn by BJS	Job No. 35-14472-002 Date October 2015

Sht. 5 of 11