

EXISTING VAULT DIMENSIONS (INCHES)

VAULT	A	B	C	D	E	F	G	H	I	J	K	L	M	N	O	P	Q	R	S	
1	64	112	N/A	N/A	N/A	N/A	N/A	52	67	21	21	N/A	N/A	N/A	N/A	57	27	**	N/A	
2	64	112	N/A	N/A	16	22	65	N/A	N/A	N/A	N/A	20	11	33	46	58	28	**	N/A	
3	64	112	13	14	14	18	N/A	50	66	19	19	N/A	11	5	46	58	24	**	6	
3A	76	120	17	12	N/A	N/A	N/A	N/A	N/A	N/A	N/A	N/A	13	35	40	77	42	**	14	
4	76	120	7	7	21	N/A	43	58	75	25	30	26	10	19	10	58	30	**	14	
5	76	120	N/A	N/A	23	N/A	47	60	73	25	36	25	13	13	17	57	43	24.00	10	
6	64	112	N/A	N/A	15	19	66	N/A	N/A	N/A	N/A	18	9	23	47	58	28	21.00	N/A	
7	64	112	N/A	N/A	16	18	65	N/A	N/A	N/A	N/A	20	9	23	43	60	31	27.00	N/A	
8	64	112	N/A	N/A	N/A	66	N/A	N/A	N/A	N/A	20	10	24	47	58	31	16.00	N/A		
9	64	112	10	10	15	17	57	66	N/A	N/A	19	20	6	3	42	58	29	13.00	6	
10	76	120	7	7	21	25	42	61	75	24	28	24	9	11	9	58	10	26 TO 31	18	
11	64	112	10	10	12	17	47	67	N/A	N/A	20	20	7	10	43	58	35	25.00	6	
12	64	112	N/A	N/A	12	18	66	N/A	N/A	N/A	N/A	17	7	23	44	58	37	29 TO 33	N/A	
13	64	112	N/A	N/A	11	17	66	N/A	N/A	N/A	N/A	17	7	26	44	58	42	24 TO 31	N/A	
14*	64	112	10	10	14	18	55	66	N/A	N/A	17	18	7	4	41	58	28	26.00	6	
15	64	112	7	8	12	18	52	68	N/A	N/A	20	20	6	1	43	58	29	6.00	6	
16	64	112	N/A	N/A	13	19	55	65	N/A	N/A	**	**	8	N/A	43	58	29	26.00	N/A	
17	76	120	**	**	23	22	46	61	73	**	**	**	9	20	13	59	22	9.00	14	
18	76	120	7	8	21	25	43	63	76	25	30	26	8	19	8	58	10	21.00	18	
19*	64	112	N/A	N/A	12	18	67	N/A	N/A	N/A	N/A	20	7	25	44	59	34	**	N/A	
20	64	112	N/A	N/A	11	17	67	N/A	N/A	N/A	N/A	19	7	25	45	59	31	21 TO 24	N/A	
21*	64	112	10	10	15	18	50	67	N/A	N/A	20	20	2	4	42	59	24	19.00	6	
22	76	120	**	**	20	25	41	59	79	**	**	**	11	20	8	59	9	10.00	18	
23	64	112	10	10	**	**	52	67	N/A	N/A	20	20	2	19	30	58	22	30 TO 36	6	
24	76	120	8	8	22	25	45	60	76	22	27	22	9	14	13	58	20	22 TO 32	14	
25	64	112	N/A	N/A	12	19	66	N/A	N/A	N/A	N/A	20	6	24	44	58	30	14.00	N/A	
26	64	112	10	10	12	21	52	67	N/A	N/A	21	21	2	10	42	59	24	16 TO 23	6	
27	76	120	**	**	17	25	40	61	76	**	**	**	7	20	30	58	12	24 TO 42	18	
28	76	120	8	8	20	25	41	60	73	**	**	**	8	12	13	58	22	24 TO 48	14	
29	64	112	10	10	12	18	49	68	N/A	N/A	20	20	2	4	43	58	23	26 TO 38	6	
30	76	120	8	8	21	24	42	60	73	**	**	**	8	12	13	58	22	14 TO 26	14	
STA. 42.04	**	**	**	**	**	**	**	**	**	**	**	**	**	**	**	**	**	**	**	**

**CONTRACTOR TO FIELD VERIFY DIMENSIONS

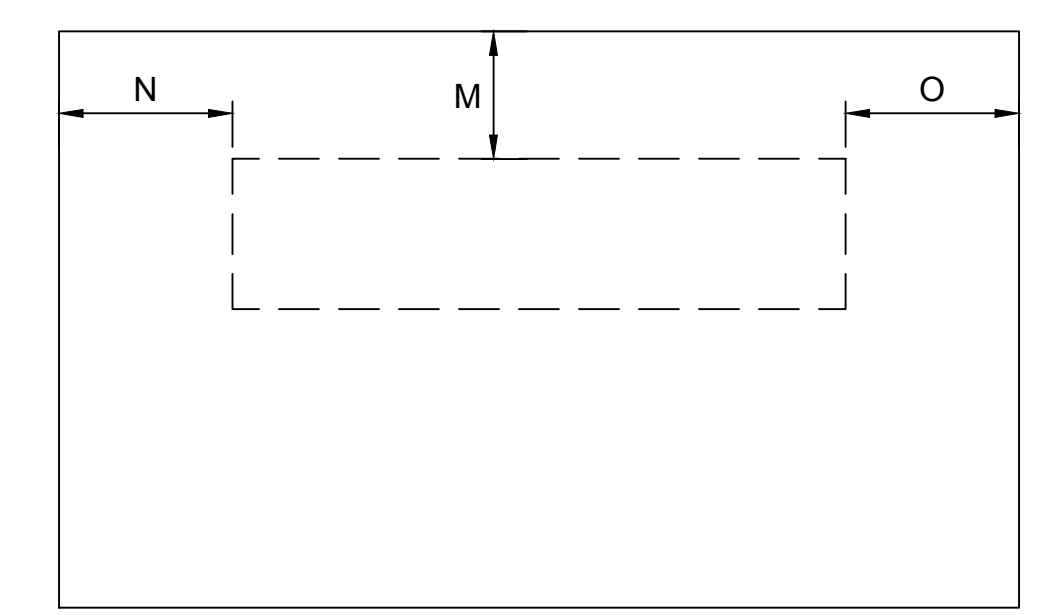
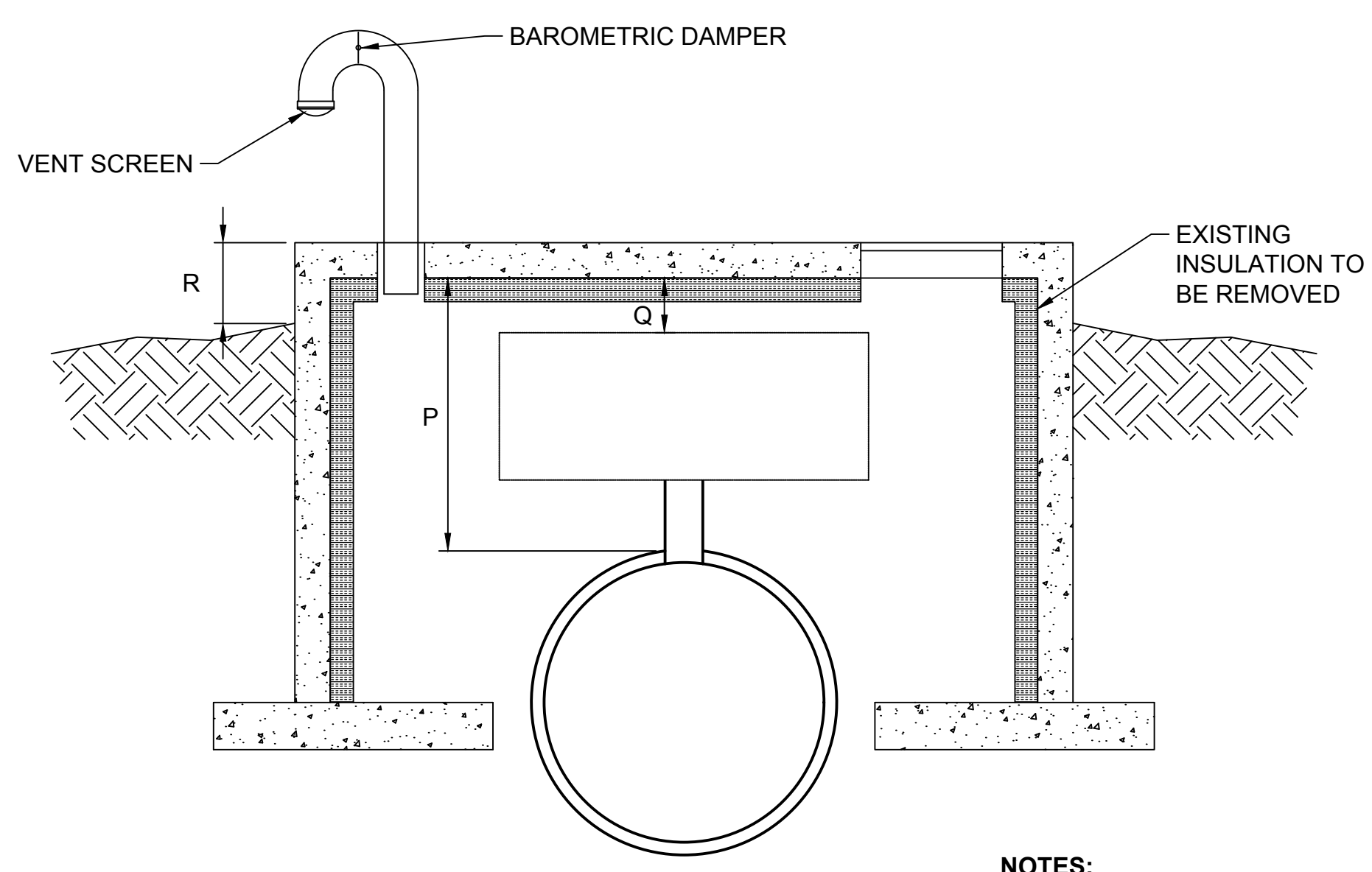
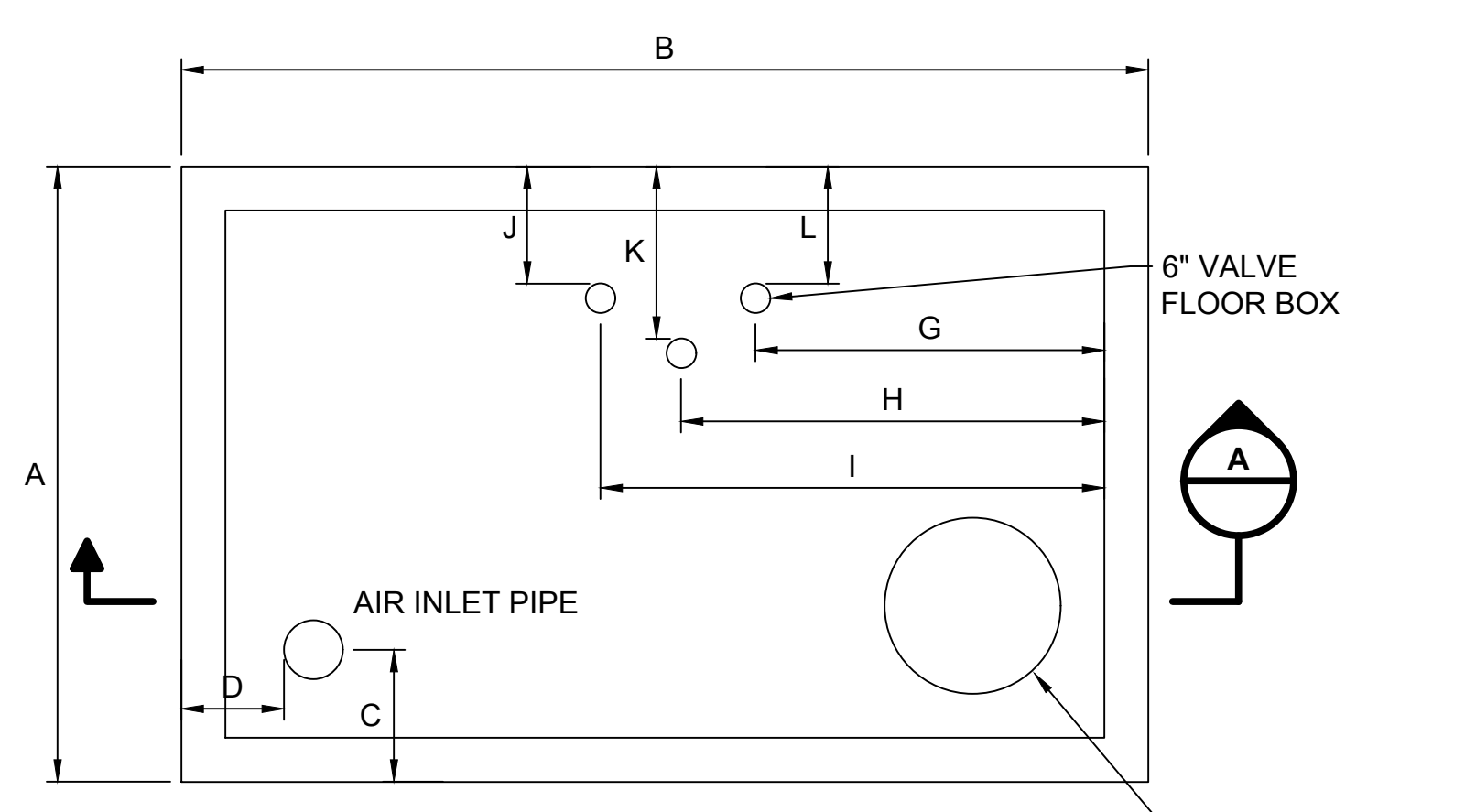
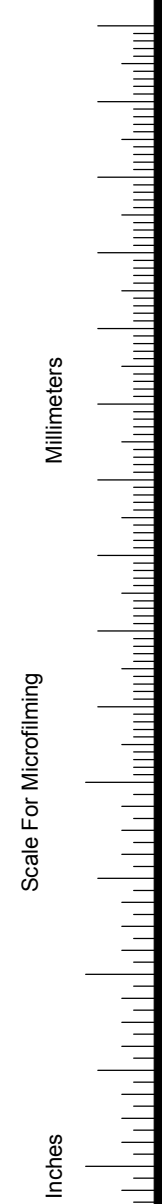

NOTES:

1. BOX REPRESENTS AREA OCCUPIED BY PIPING AND VALVES.
2. DIMENSIONS OF BOXED AREA REPRESENT THE CLOSEST POINT FROM THE PIPING TO THE VAULT WALL

NOTES:

1. BOX REPRESENTS AREA OCCUPIED BY PIPING AND VALVES.
2. DIMENSIONS OF BOXED AREA REPRESENT THE CLOSEST POINT FROM THE PIPING TO THE VAULT WALL

no.	date	by	ckd	description
0	11/8/17	CAM	LJK	ISSUED FOR BID



9400 WARD PARKWAY
KANSAS CITY, MO 64114
816-333-9400
LICENSEE NO. E-65

date	designed	detailed
SEPTEMBER 11, 2017	C. MAGES	B. FIFIELD
checked	L. KLEIN	



CHENEY TRANSMISSION LINE

EXISTING CONDITIONS

project	contract
97687	CONTRACT
drawing	rev.
D001	0
sheet	of sheets
file 97687_D001.DWG	