

FHWA REGION NO.	STATE	PROJECT NUMBER	FISCAL YEAR	SHEET NUMBER	TOTAL SHEETS
7	KANSAS	87N-0128-01	1999	44	118

BY	DATE
REFERENCES NOTED	
REFERENCES CHECKED	

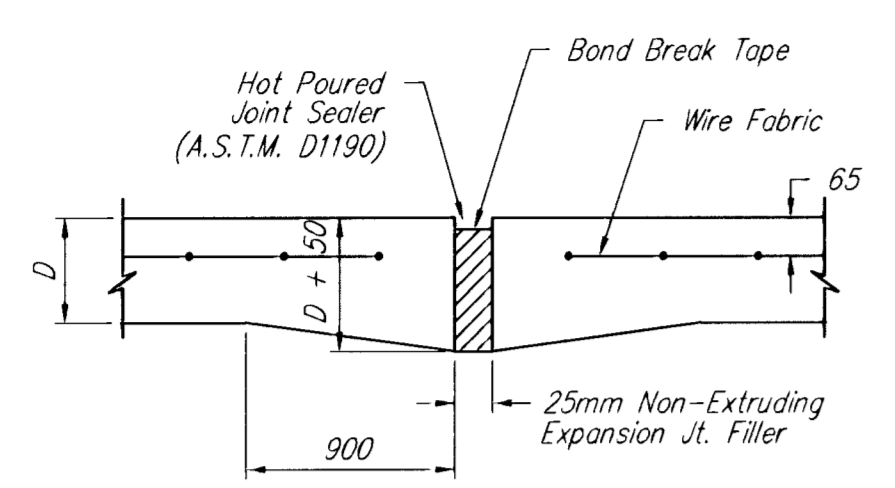

EXPANSION JOINT

NOTE: Extra Thickness to be Subsidiary to Price of Square Meters Pavement

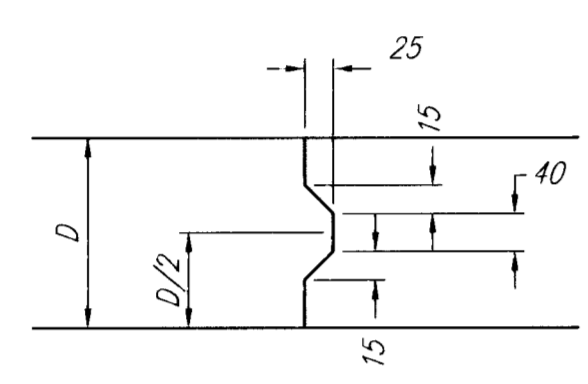

KEYWAY DETAIL

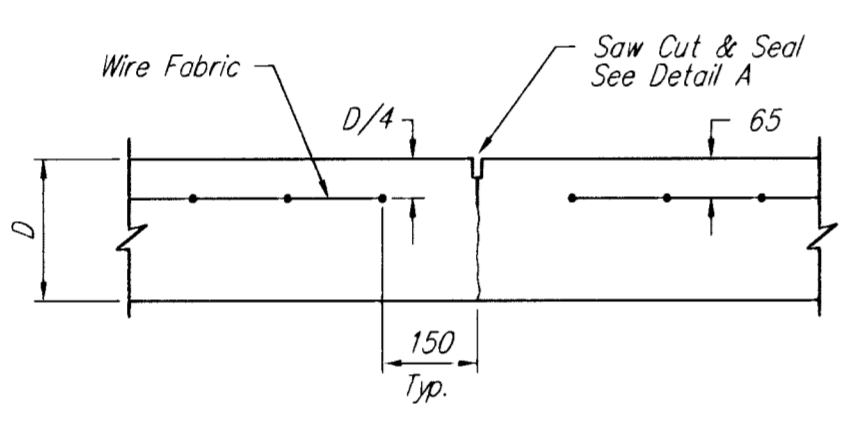

CONTRACTION JOINT DETAIL (C.J.)

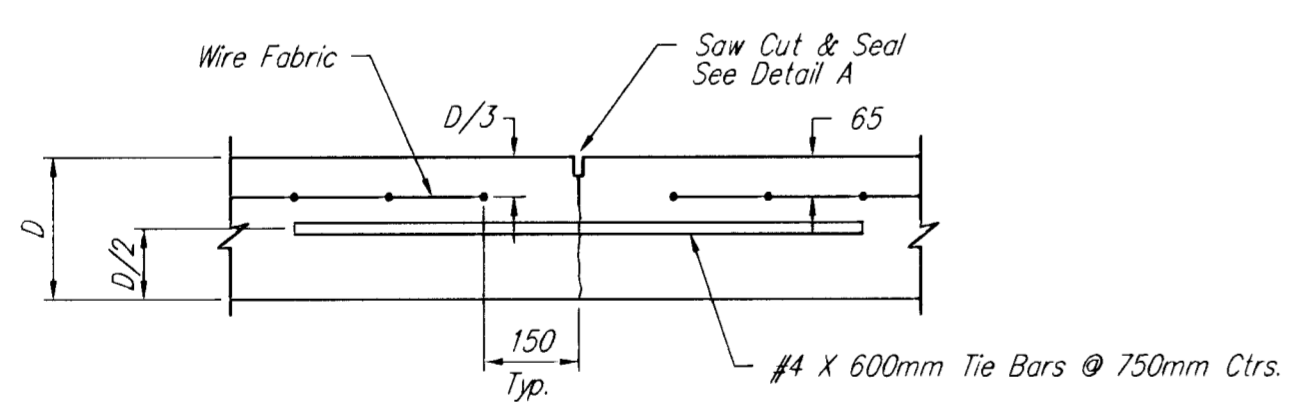

LONGITUDINAL JOINT DETAIL (L.J.)

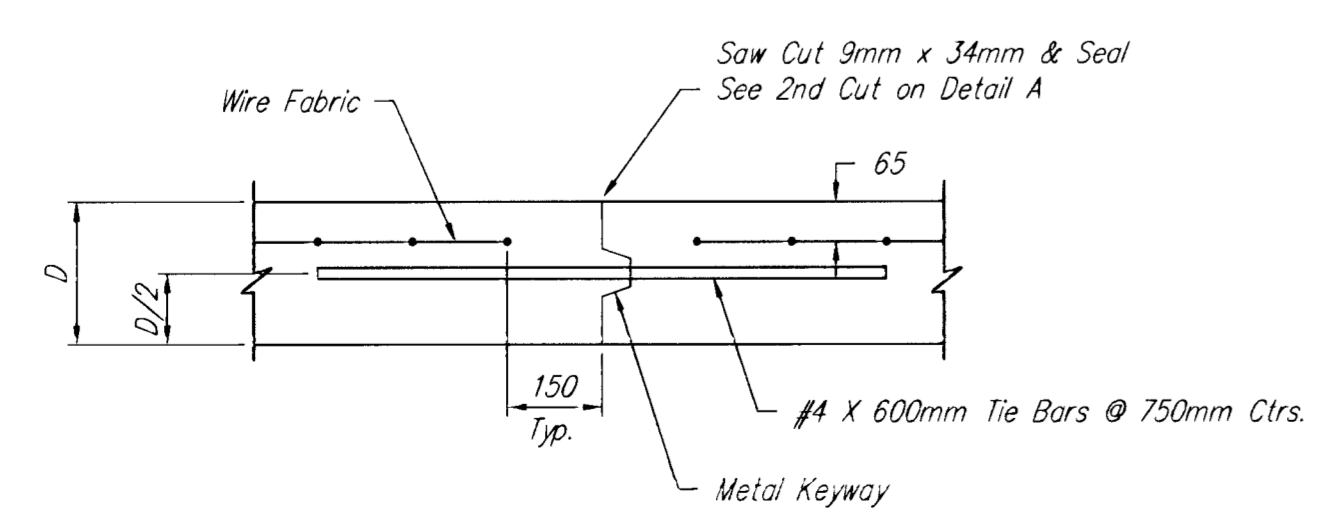

OPTIONAL LONGITUDINAL JOINT DETAIL (L.J.)

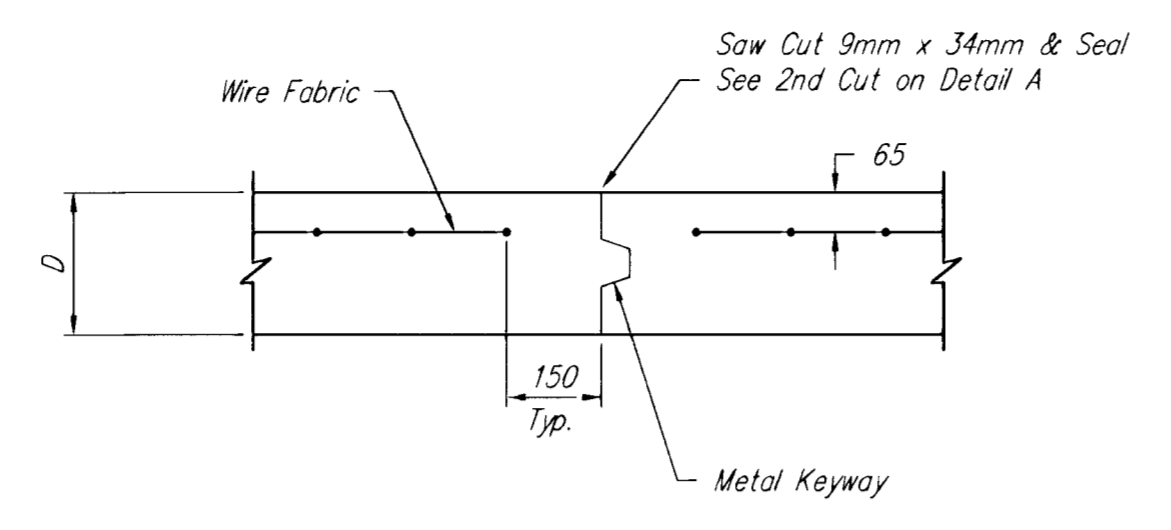

OPTIONAL CONTRACTION JOINT

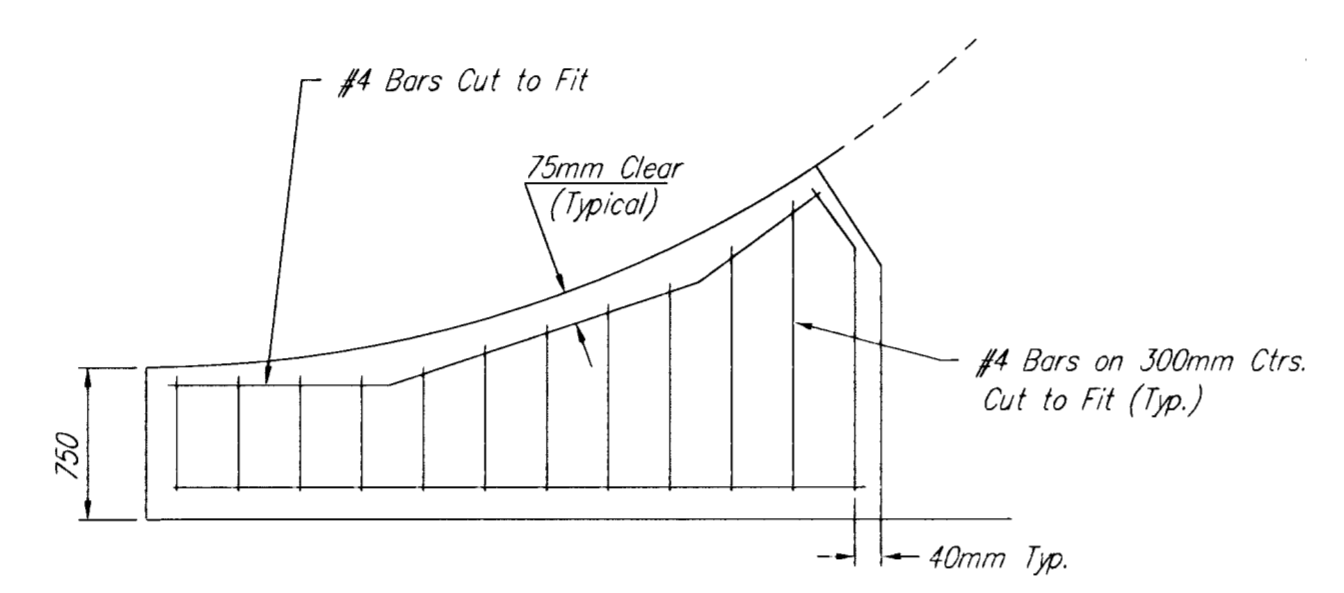

WING REINFORCING DETAIL

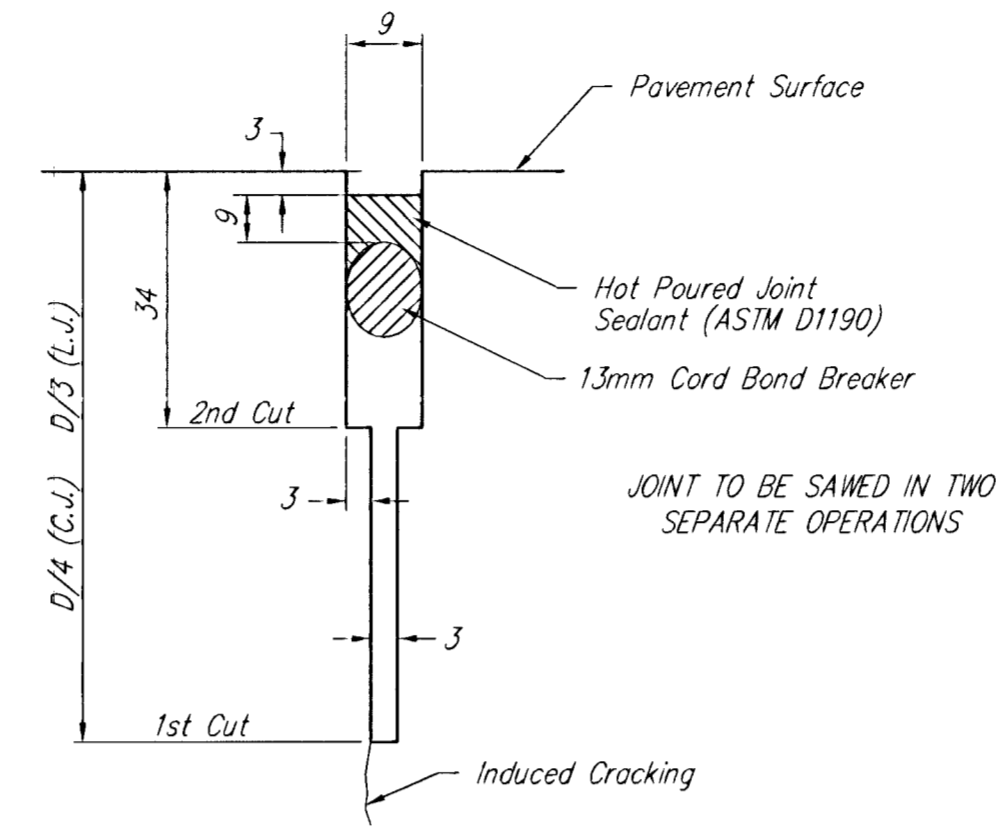

SAW JOINT DETAIL

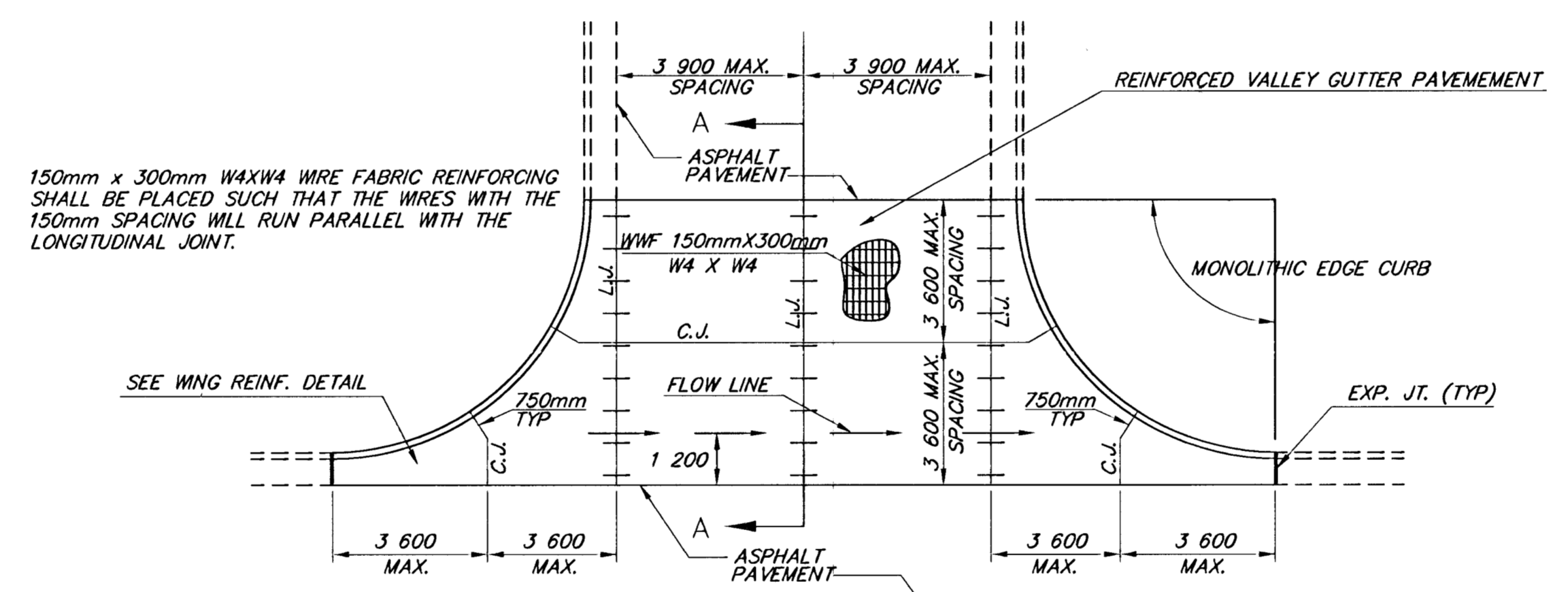

PLAN

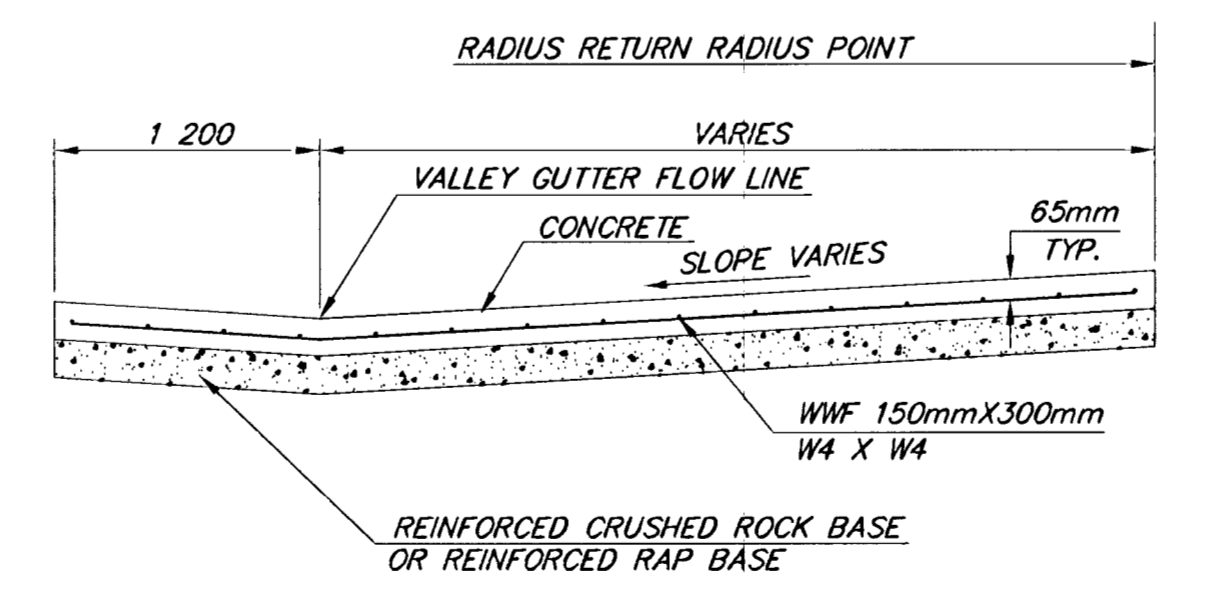

SECTION A-A

REINFORCED VALLEY GUTTER DETAIL

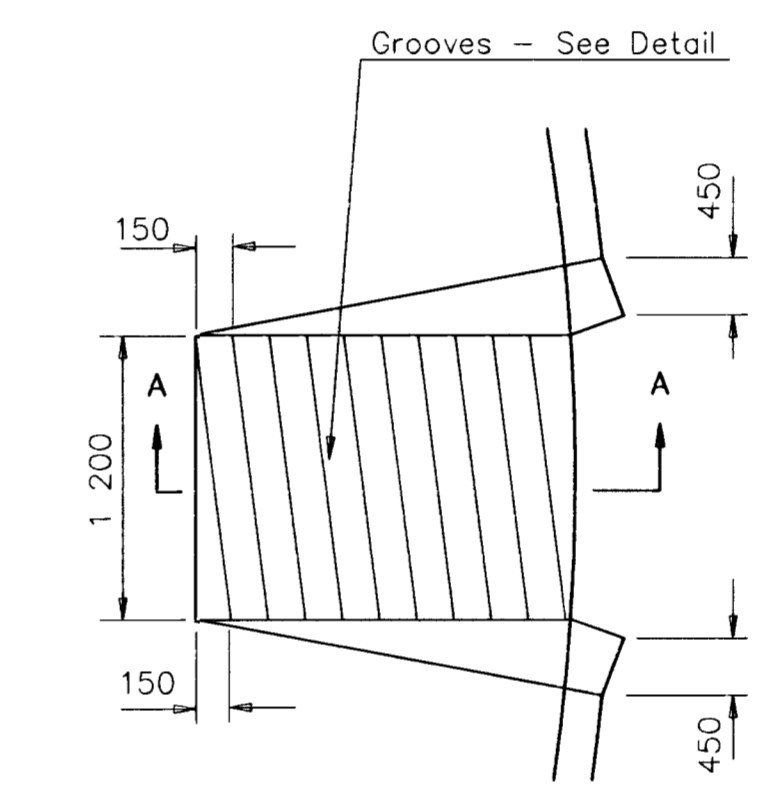

WHEELCHAIR RAMP PLAN VIEW

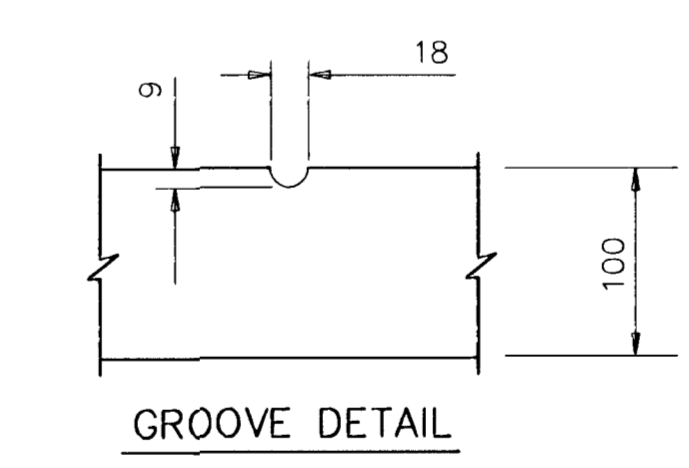

GROOVE DETAIL

WHEELCHAIR RAMP DETAIL

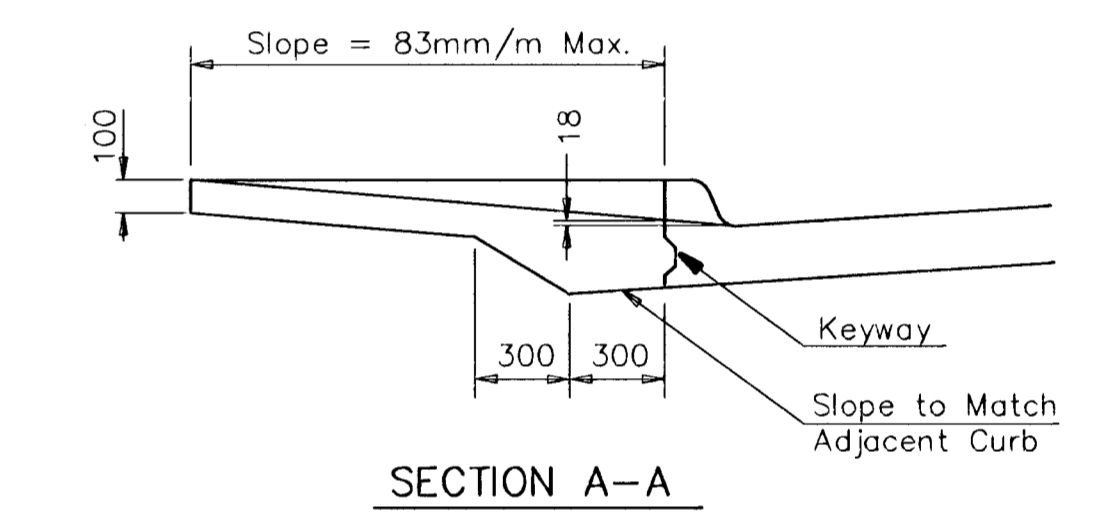

SECTION A-A

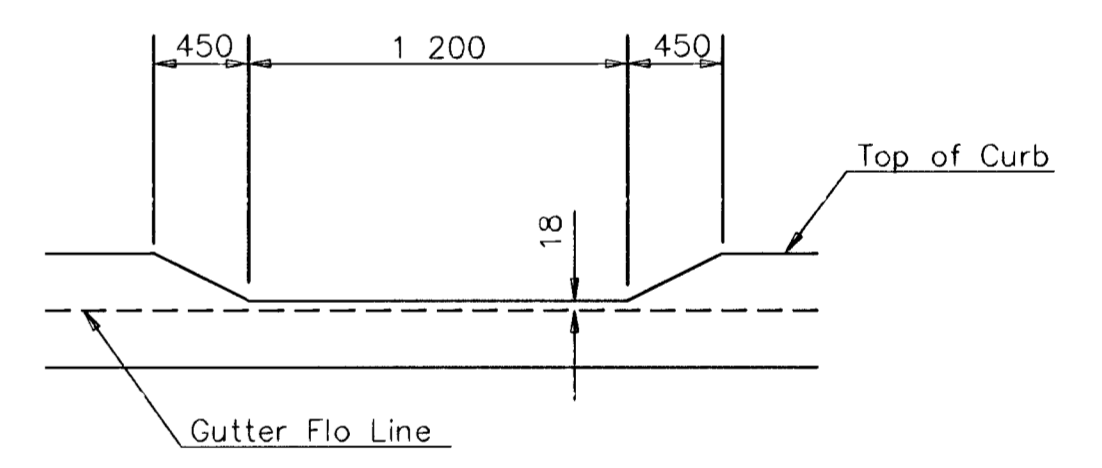

DEPRESSED CURB DETAIL

**VALLEY GUTTER DETAILS
WHEELCHAIR RAMP DETAILS**

SRB 324 NORTH MAIN 316-284-8008
WICHITA, KANSAS 67203 FAX 284-4621
http://www.feist.com/~srb E-Mail: srbs@feist.com

SAVOY, RUGGLES & BOHM, P.A.
ENGINEERING & SURVEYING

PROJECT NUMBER
472-76-245-83057-000-000-001

DRAWN	DESIGN	REVIEW	DATE	UTILITY	SRB JOB
JRA	KWL		Dec. 13, 2000		1218T

44
118