

PLOTED: Wednesday, November 29, 2017 @ 03:04PM

J:\PROJECTS\2017\1401040290 - COW\_127THE\_13TH TO 21ST\05-CIVIL\CAO\BRIDGE\142902D10.DWG

SLAB ELEVATIONS														
1	2	3	4	Formwork			Screed		Thickness			Deck Profile		
				5	6	7	8	9	10	11	12	13	14	15
Survey	Station	† Location	Transverse Location	Target Elevation TOF	Actual Elevation TOF	TOF Variance (QA/QC)	Target Screed El. = TOC El.	Actual Bottom of Screed Elevation Prior to Pour	Screed Variance (QA/QC)	Plan Deck Thickness	Measured Deck Thickness	Deck Thickness Variance (QA/QC)	Plan TOC El.	Actual TOC El. Optional Survey
	(1)(16)	(13)	(13)	(1)(6)	(2)(± in)	(2)(5)	(1)(6)	(2)(± in)	(2)(7)	(in)	(1)(in)	(2)(8)(± in)	(2)(9)	(1) Date: (3)
A	23+47.03	C. Brg. of Abut. #1	Left Fascia	/	/	/	-	-	-	/	/	/	1344.76	
	23+28.56		Crown Gr. C	/	/	/	-	-	-	/	/	/	1345.10	
	23+14.12		Right Fascia	/	/	/	-	-	-	/	/	/	1344.58	
B	23+48.48	Interior Face of Abut. #1	Left Fascia	/	/	/	/	/	/	14.0	/	/	1344.78	/
	23+30.00		Crown Gr. C	/	/	/	/	/	/	-	/	/	1345.12	/
	23+15.57		Right Fascia	/	/	/	/	/	/	14.0	/	/	1344.59	/
C	23+59.03	4/10 Point from Abut. #1	Left Fascia	/	/	/	/	/	/	14.1	/	/	1344.87	/
	23+40.56		Crown Gr. C	/	/	/	/	/	/	-	/	/	1345.22	/
	23+26.12		Right Fascia	/	/	/	/	/	/	14.1	/	/	1344.69	/
D	23+75.59	Span #1 Face of Pier Beam	Left Fascia	/	/	/	/	/	/	22.0	/	/	1345.02	/
	23+57.11		Crown Gr. C	/	/	/	/	/	/	-	/	/	1345.37	/
	23+42.68		Right Fascia	/	/	/	/	/	/	22.0	/	/	1344.84	/
E	23+77.03	C. Brg. of Pier #1	Left Fascia	/	/	/	/	/	/	/	/	/	1345.03	/
	23+58.56		Crown Gr.	/	/	/	/	/	/	/	/	/	1345.37	/
	23+44.12		Right Fascia	/	/	/	/	/	/	/	/	/	1344.85	/
F	23+78.48	Span #2 Face of Pier Beam	Left Fascia	/	/	/	/	/	/	22.0	/	/	1345.05	/
	23+60.00		Crown Gr. C	/	/	/	/	/	/	-	/	/	1345.39	/
	23+45.57		Right Fascia	/	/	/	/	/	/	22.0	/	/	1344.86	/
G	23+97.03	Midpoint of Span #2	Left Fascia	/	/	/	/	/	/	14.0	/	/	1345.21	/
	23+78.56		Crown Gr. C	/	/	/	/	/	/	-	/	/	1345.56	/
	23+64.12		Right Fascia	/	/	/	/	/	/	14.0	/	/	1345.03	/
H	24+15.59	Span #2 Face of Pier Beam	Left Fascia	/	/	/	/	/	/	22.0	/	/	1345.38	/
	23+97.11		Crown Gr. C	/	/	/	/	/	/	-	/	/	1345.73	/
	23+82.68		Right Fascia	/	/	/	/	/	/	22.0	/	/	1345.20	/
I	24+17.03	C. Brg. of Pier #2	Left Fascia	/	/	/	/	/	/	/	/	/	1345.39	/
	23+98.56		Crown Gr. C	/	/	/	/	/	/	/	/	/	1345.73	/
	23+84.12		Right Fascia	/	/	/	/	/	/	/	/	/	1345.21	/
J	24+18.48	Span #3 Face of Pier Beam	Left Fascia	/	/	/	/	/	/	22.0	/	/	1345.41	/
	24+00.00		Crown Gr. C	/	/	/	/	/	/	-	/	/	1345.75	/
	23+85.57		Right Fascia	/	/	/	/	/	/	22.0	/	/	1345.22	/
K	24+35.03	6/10 Point from Pier #2	Left Fascia	/	/	/	/	/	/	14.1	/	/	1345.56	/
	24+16.56		Crown Gr. C	/	/	/	/	/	/	-	/	/	1345.90	/
	24+02.12		Right Fascia	/	/	/	/	/	/	14.1	/	/	1345.37	/
L	24+45.59	Interior Face of Abut. #2	Left Fascia	/	/	/	/	/	/	14.0	/	/	1345.65	/
	24+27.11		Crown Gr. C	/	/	/	/	/	/	-	/	/	1346.00	/
	24+12.68		Right Fascia	/	/	/	/	/	/	14.0	/	/	1345.47	/
M	24+47.03	C. Brg. of Abut. #2	Left Fascia	/	/	/	/	/	/	/	/	/	1345.66	/
	24+28.56		Crown Gr. C	/	/	/	/	/	/	/	/	/	1346.00	/
	24+14.12		Right Fascia	/	/	/	/	/	/	/	/	/	1345.48	/

† Stationing shown from South to North

NOTE: The Contractor will turn in a completed copy of this table to the Design Engineer for review.

\* It is assumed that piling have been driven to design bearing and checked by ENR formula (QA/QC). No allowance for pile settlement is included in crush.

Pour Dates (2)	
Deck	
Left Rail (13)	
Right Rail (13)	

Survey Data (1)(11)	
Bench Mark No.	Elevation
BM#2	1342.27
BM#4	1354.41

Crown Grade Profile (1)(12)	
23+28.56	VPI Station
1345.10	VPI Elevation
0.90	G1 %
N/A	G2 %
N/A	L in Stations

Slab Thickness (1)	
14"	Uniform Depth (inch)
8"	Haunch Depth @ Face of PB (inch)

Span Data (1)	
HL-93	Design Loading
30'	Span #1 (ft)
40'	Span #2 (ft)
2 1/2"	Clear Cover (inch)

Roadway Data (1)(10)(13)	
18'	Deck Width (ft)(Ph2)
11'	Deck Width (ft)(Ph3)
1.60	% Slope Left (±)
1.60	% Slope Right (±)
30'0"0"	Skew (dd:mm:ss)

Camber (1)(17)	
0.0233'	Span #1 0.4 Point (ft)
0.0350'	Span #2 Midspan (ft)

Legend  
 TOF = Top of Formwork  
 TOC = Top of Concrete  
 QA = Quality Assurance  
 QC = Quality Control

- (1) By the Design Engineer
- (2) By the Contractor
- (3) By Request
- \* (4) Based on hardwood shims, assume 6 joints with 1/8" crush (Take Up) per joint. Revise estimate if/when more accurate information becomes available. Ref: "Formwork for Concrete" Fifth Edition, by M.K. Hurd, Chapter 6
- (5) (col 7 - col 6)x12
- (6) Crush (Take Up) and camber must be included
- (7) (col 10 - col 9)x12
- (8) (col 10 - col 7)x12
- (9) (col 13 - col 12)
- (10) If transition falls on the bridge, then enter "Varies" for the % Slope
- (11) From "Construction Layout" sheet
- (12) If bridge is not on the vertical curve, enter Abutment #1 C bearing elevation from the "Construction Layout" sheet. Represent a change in grade with G1 only.
- (13) Looking Up-Station
- (14) Out-to-Out
- (15) Ignore Fillet
- (16) Non-skewed bridges only require C stations.
- (17) Ignore theoretical camber at face of pier beams

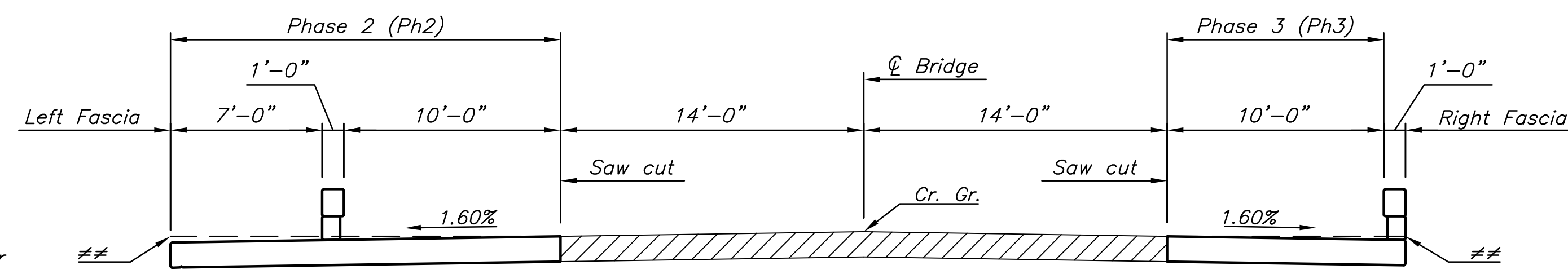

TYPICAL DECK SECTION  
(Shown Normal to C Prop. Imp.)

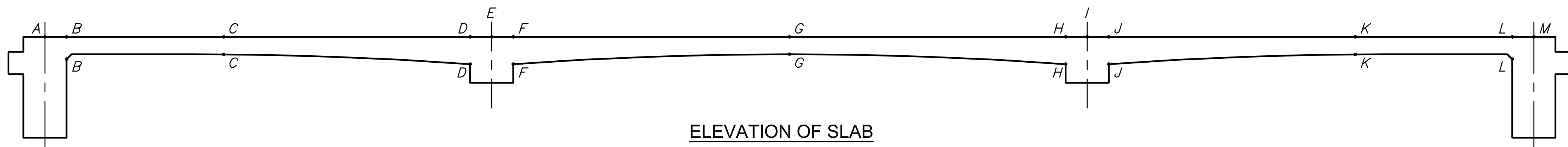

ELEVATION OF SLAB



STREET IMPROVEMENTS FOR  
**127TH STREET EAST**  
 FROM 13TH STREET NORTH TO 21ST STREET NORTH

©2017 MKEC Engineering All Rights Reserved  
 These drawings and their contents, including, but not limited to, all concepts, designs, & ideas are the exclusive property of MKEC Engineering (MKEC), and may not be used or reproduced in any way without the express consent of MKEC.

SLAB ELEVATIONS

PROJECT NO.	472-85158	
DATE	11/29/17	
SCALE	NTS	
DESIGNED	DRAWN	CHECKED
KJS	RAM	KJS

NO.	REVISION	DATE

SHEET NO.