

FHWA REGION NO.	STATE	PROJECT NO.	YEAR	SHEET NO.	TOTAL SHEETS
7	KANSAS	87-U-1362-01	1993	42	149

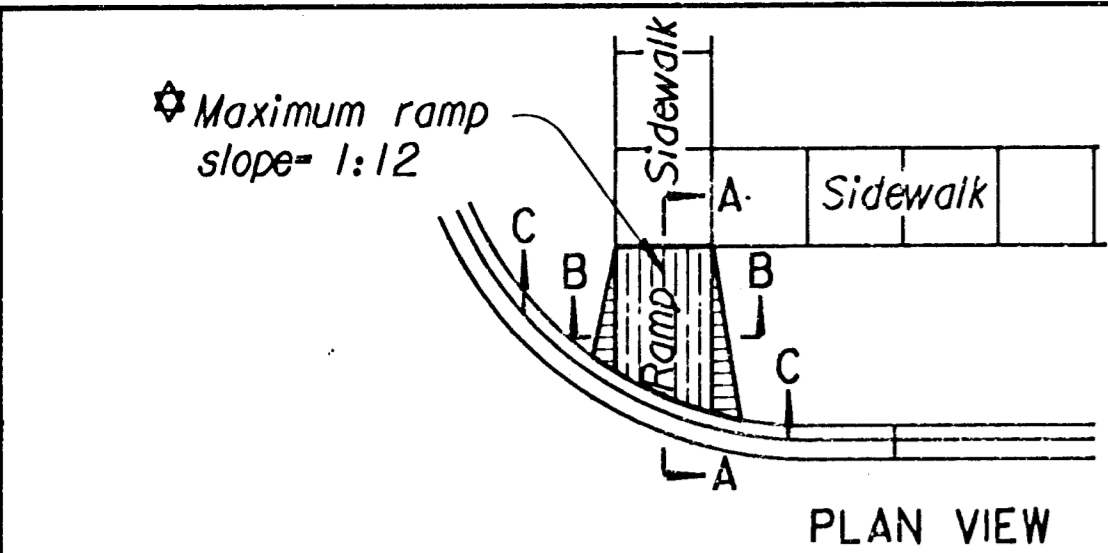

PLAN VIEW

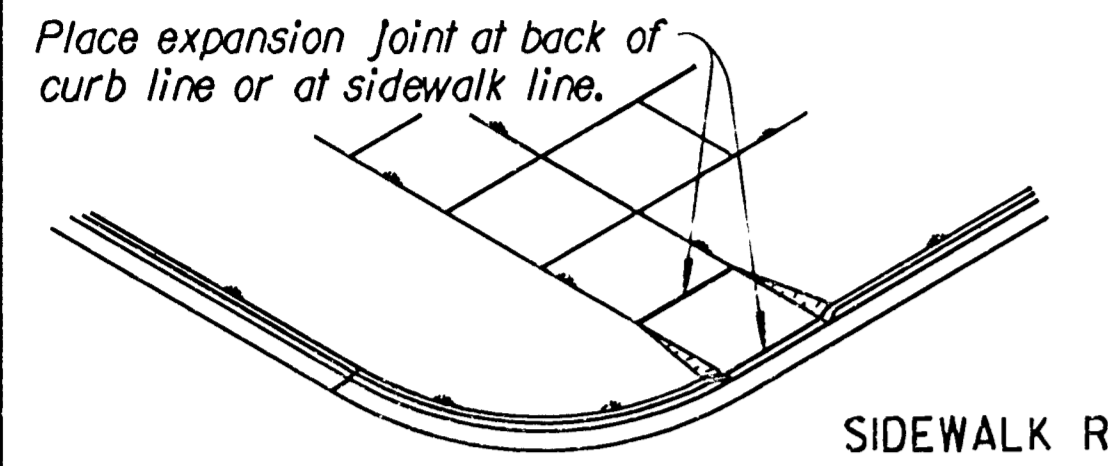

SIDEWALK RAMP TYPE 1

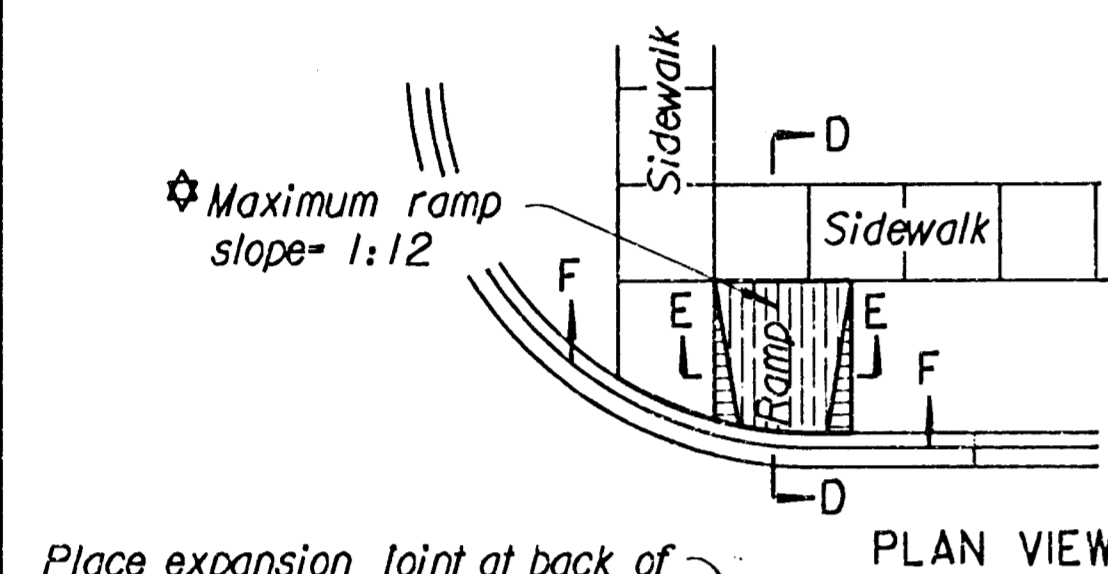

PLAN VIEW

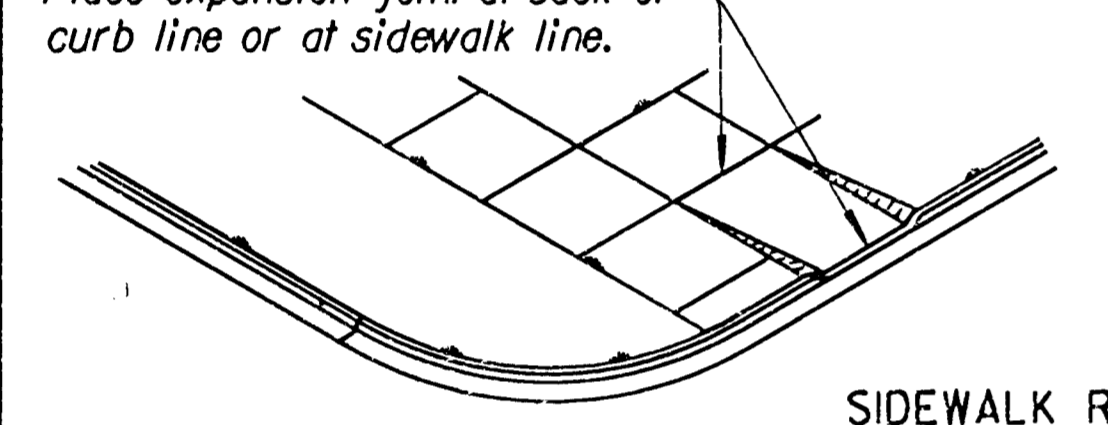

SIDEWALK RAMP TYPE 2

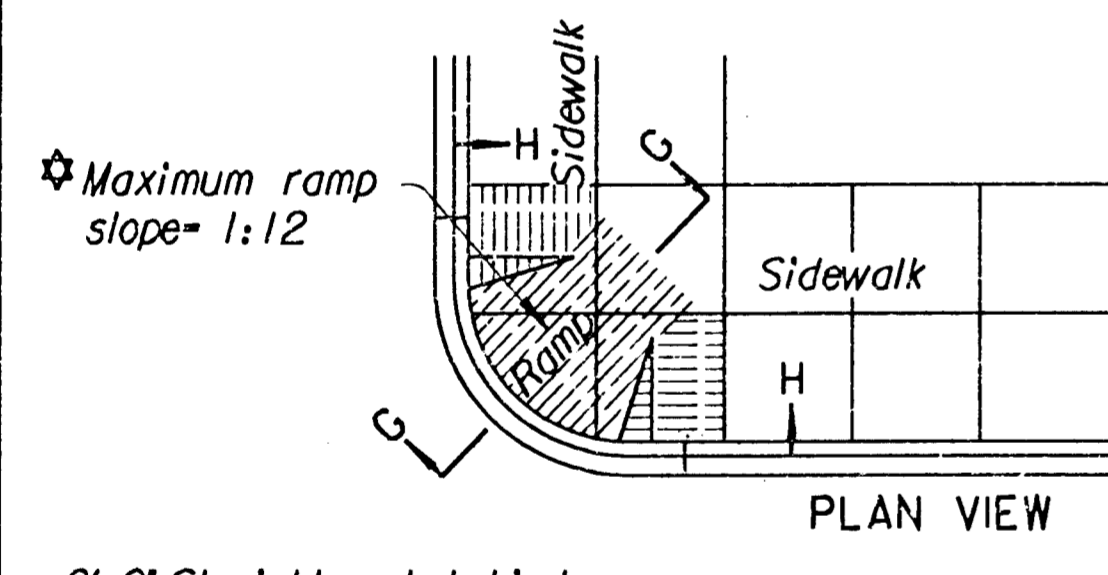

PLAN VIEW

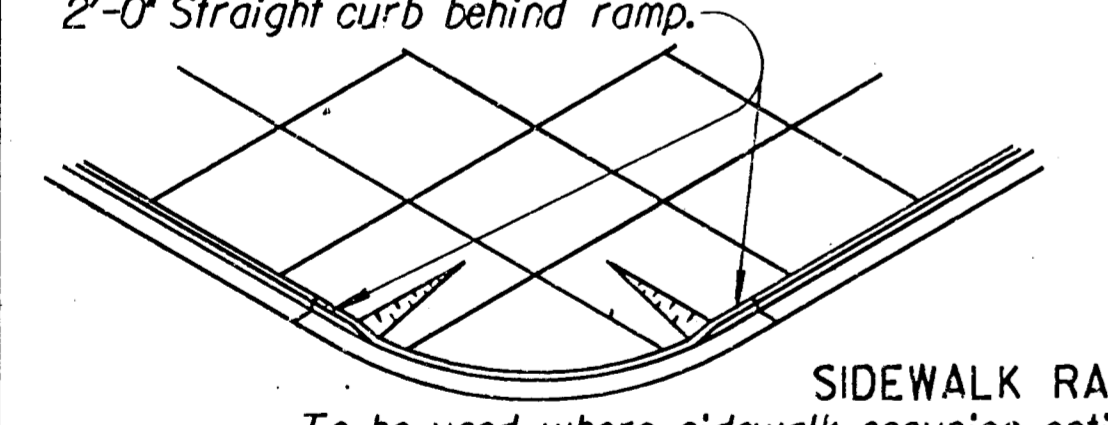

SIDEWALK RAMP TYPE 3

To be used where sidewalk occupies entire area between curb and property line.

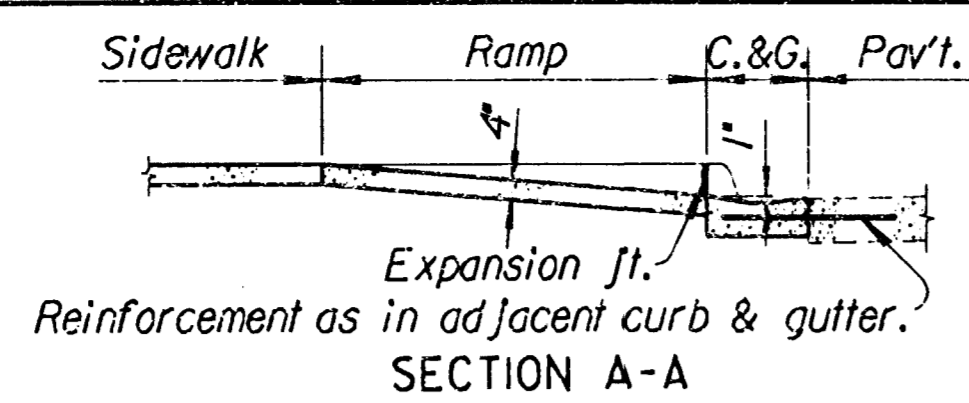

SECTION A-A

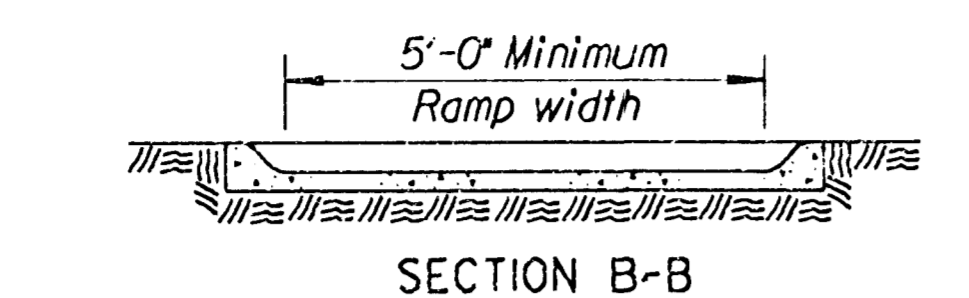

SECTION B-B

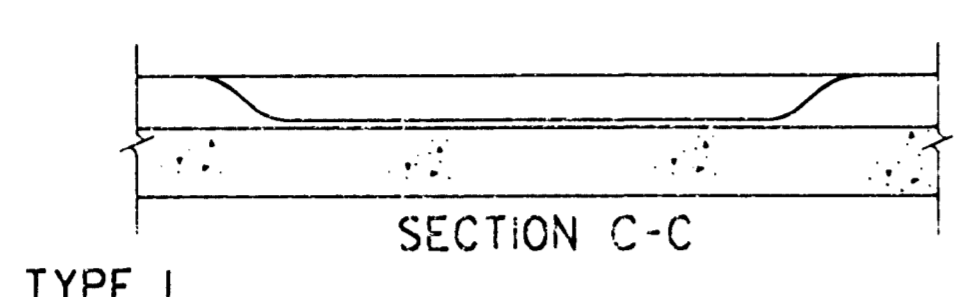

SECTION C-C

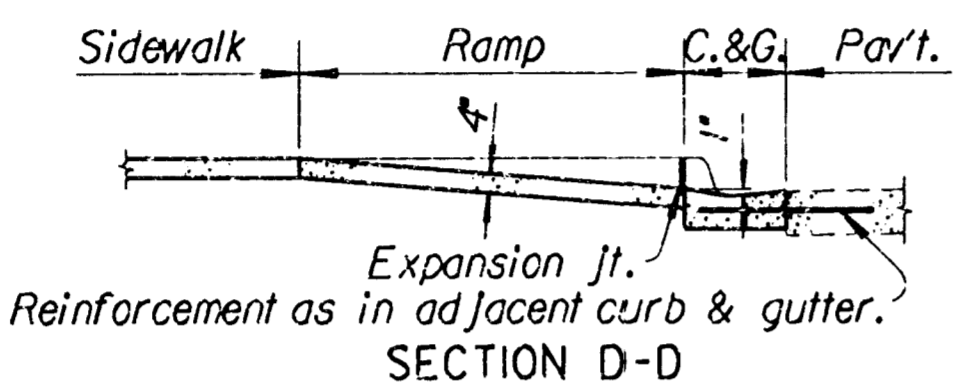

SECTION D-D

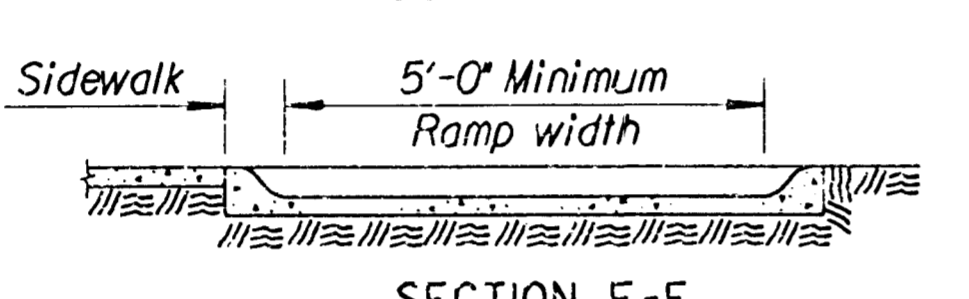

SECTION E-E

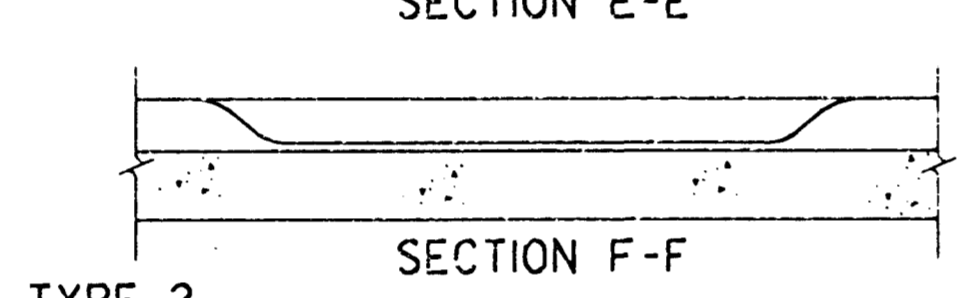

SECTION F-F

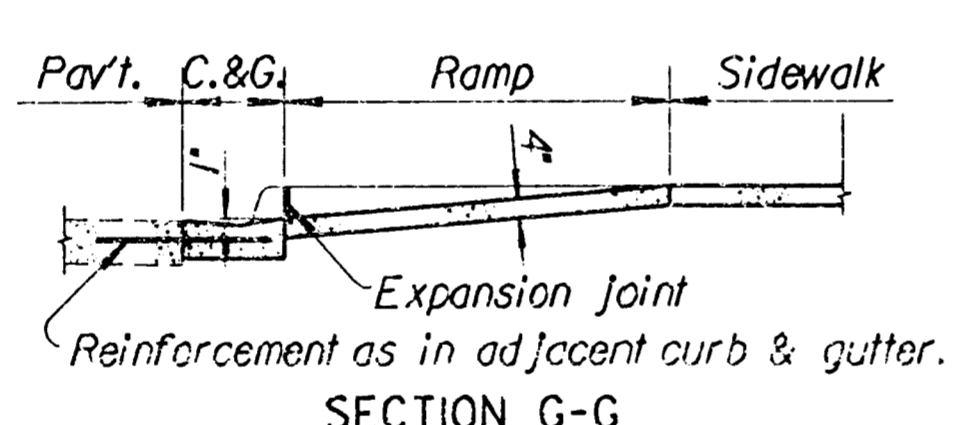

SECTION G-G

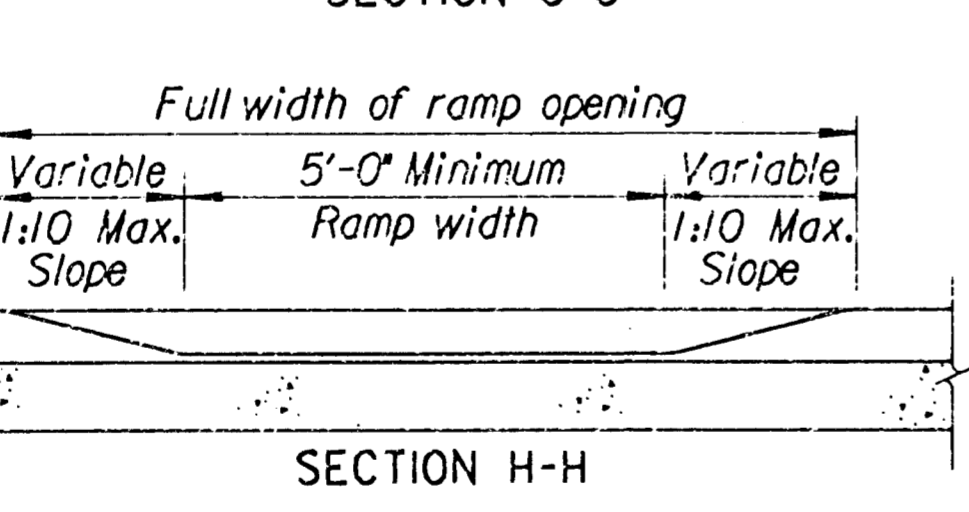

SECTION H-H

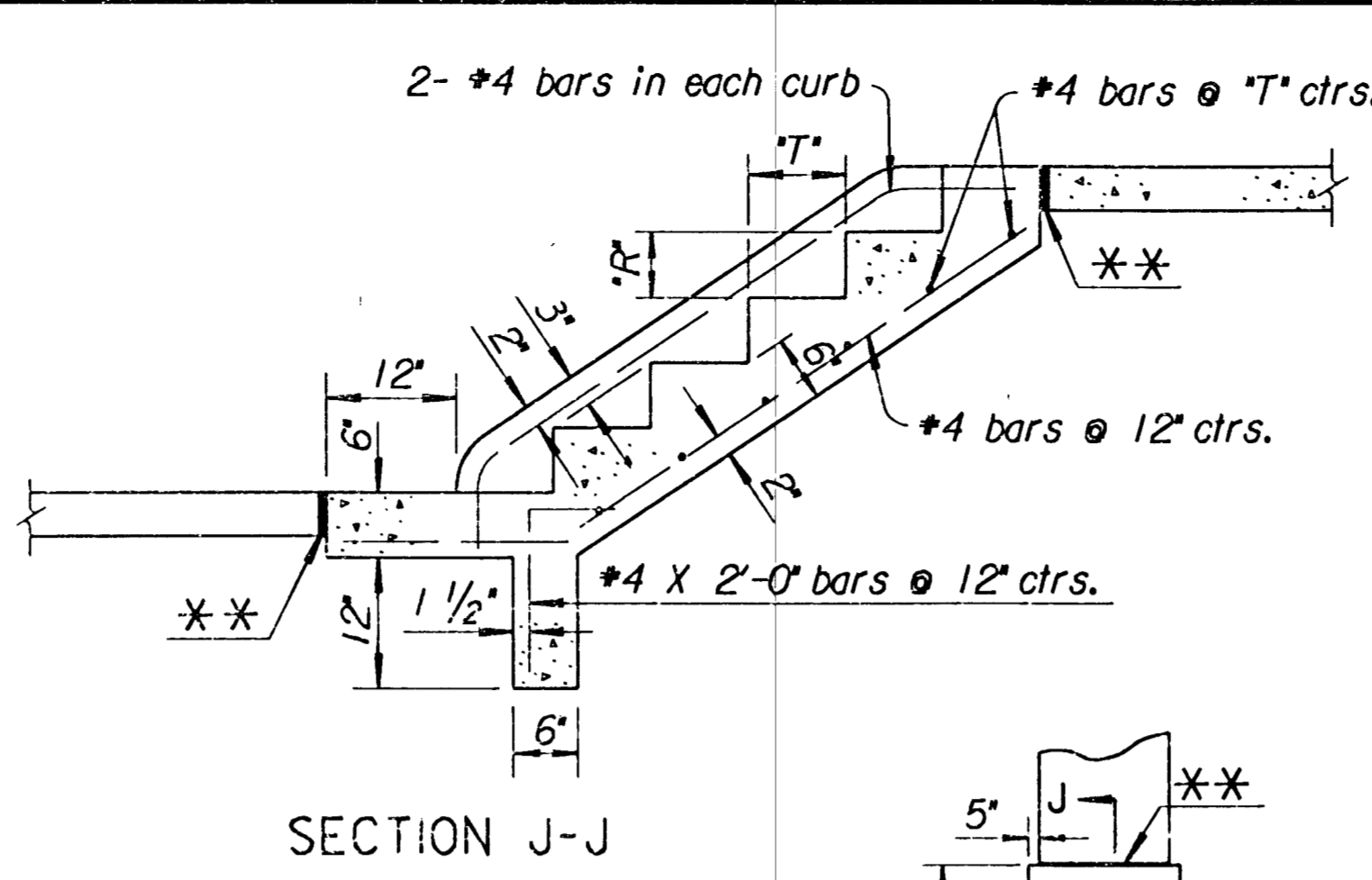

SECTION J-J

Step formula:  
 $R \times T = \text{not less than } 70 \text{ nor more than } 75.$   
 The maximum  $R = 7\frac{3}{4}$   
 The minimum  $T = 9'$

Maximum ramp slope in new construction shall be 1:12. Desirable maximum ramp slope on existing sites shall be 1:12. Where space limitations prohibit construction of 1:12 slopes at existing sites maximum slopes shall be as follows:  
 1:8 for a maximum rise of 3 inches  
 1:10 for a maximum rise of 6 inches

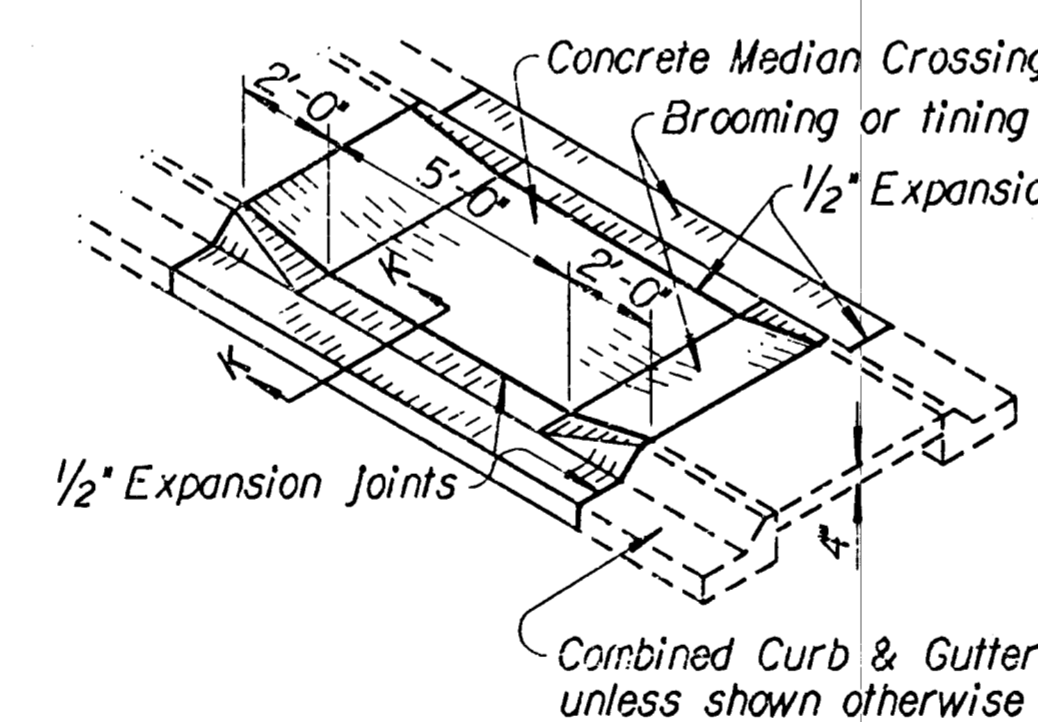

MEDIAN RAMP CROSSING

Note: A Median Ramp Crossing shall be constructed at Crosswalk locations.

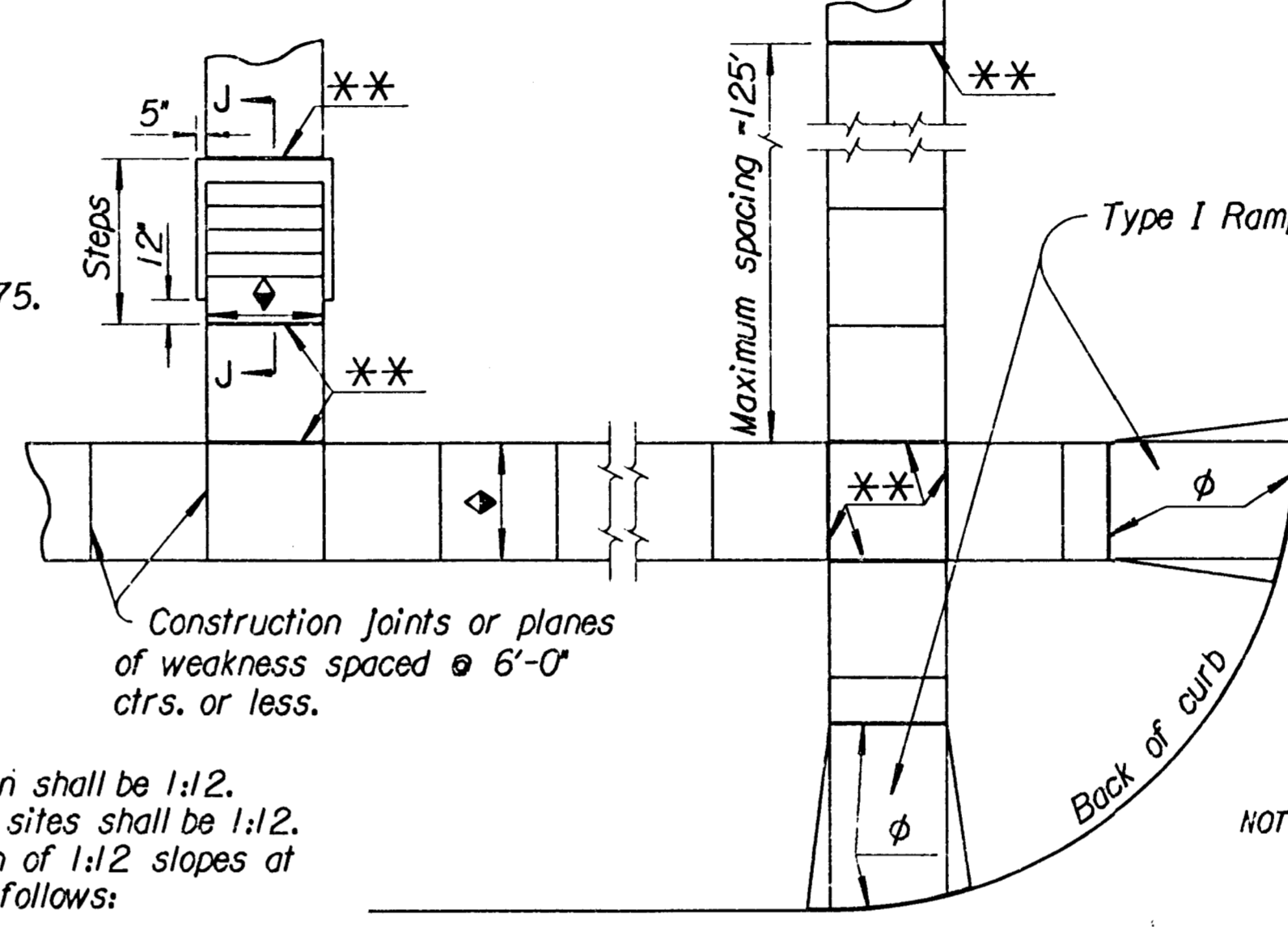

TYPICAL PLAN

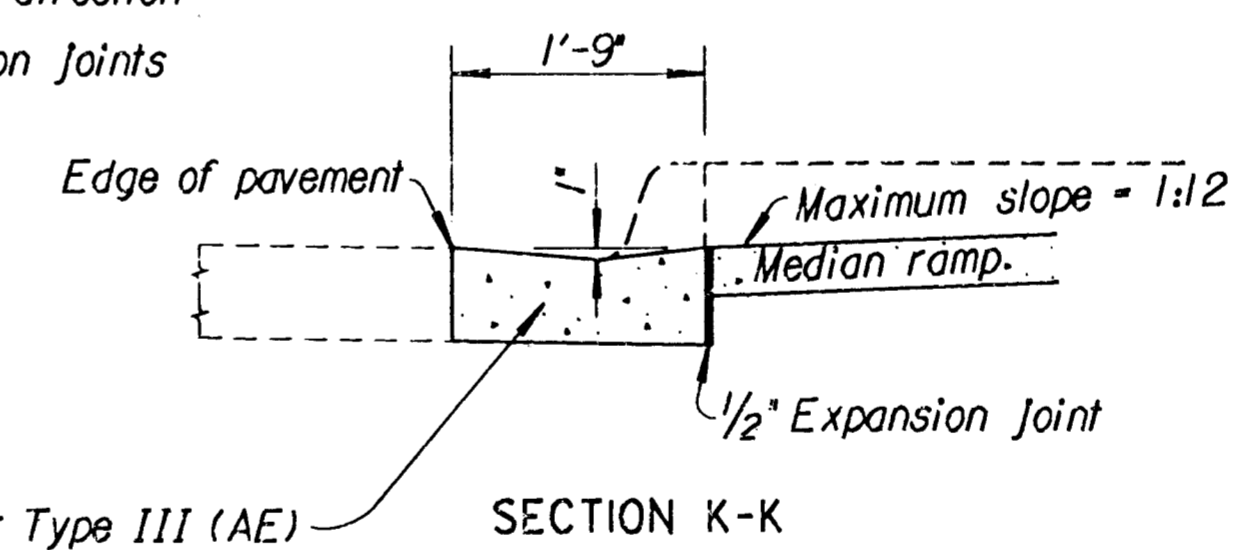

SECTION K-K

Shaping of curb and gutter and median crossing to be subsidiary to other bid items.

Note: Reinforcing bars shown are to be used only when more than four steps are necessary. Where field conditions permit, the steps should not be constructed too steep.

Expansion Joint (3/4" Redwood board) placed at either back of curb line or at sidewalk line.

Expansion Joint (3/4" redwood board) located as shown.

Variable width (5'-0" min.). Entrance walk to be same width as approach walk. Sidewalk width of 4'-0" may be used where existing conditions prohibit use of 5'-0".

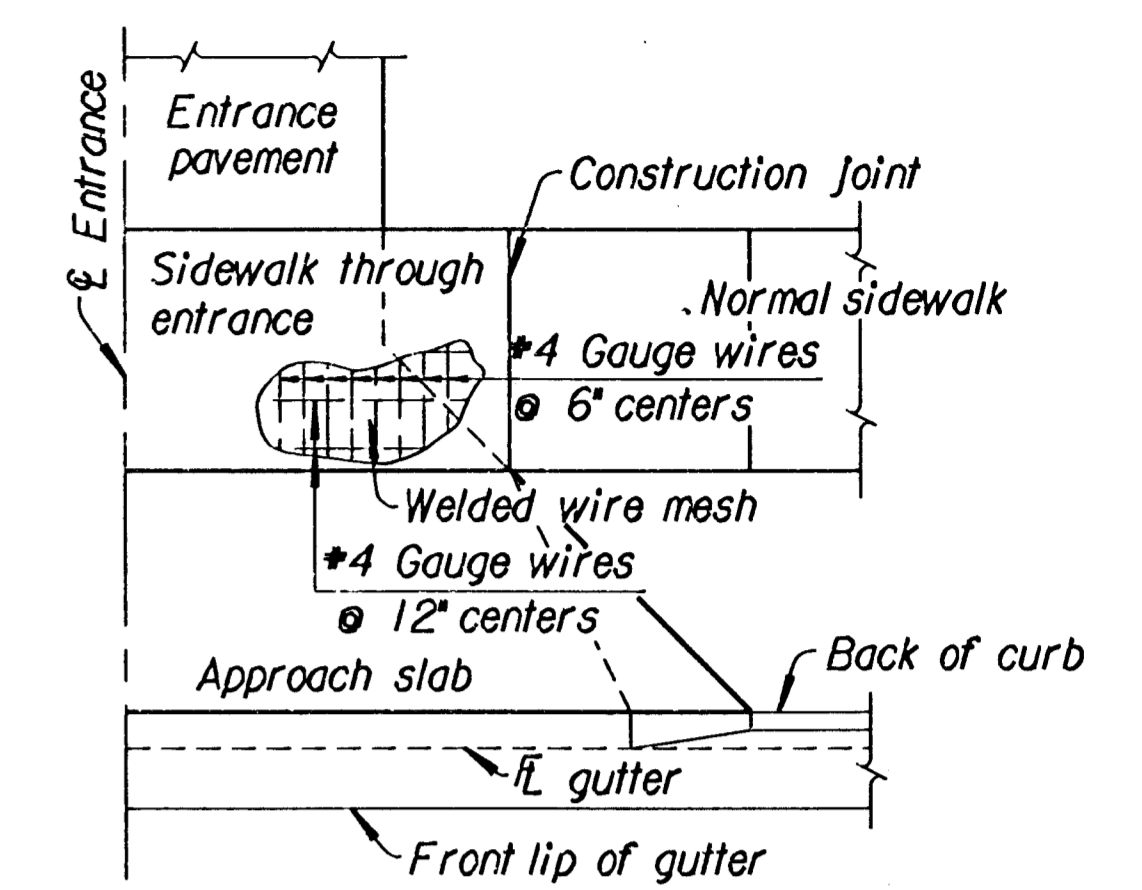

REINFORCEMENT DIAGRAM SIDEWALK THROUGH ENTRANCE

See Std. No. 726.1 for details of Alley and Entrance Pavement.

NOTES: Ramps shall be provided at all corners of street intersections where there is existing or proposed sidewalk and curb. Ramps shall also be provided at walk locations in mid-block in the vicinities of hospitals, medical centers and athletic stadiums. Details shown on this sheet apply to all construction or reconstruction of streets, curbs or sidewalks. Use of sidewalk ramp Type 2 shall be restricted to locations where it is not feasible to use Types 1 or 3. Curb cut ramps are to be located as shown on the plans or as directed by the Engineer. The normal gutter line profile shall be maintained through the area of the ramp. If possible, drainage structures should not be placed in line with ramps. Except where existing drainage structures are being utilized in the new construction, location of the ramp should take precedence over location of drainage structure. Sidewalks shall be ramped where the driveway curb is extended across the walk. Care shall be taken to assure a uniform grade on the ramp, free of sags and short grade changes. Expansion joints shall be placed in sidewalks as follows: In long runs, expansion joints shall be 3/4" redwood boards flush with the surface, at a maximum spacing of 125'. This same joint should be used at sidewalk junctions as shown in Typical Plan. Where the end of the sidewalk abuts a curb, a 3/4" redwood board flush with the surface shall be used. Where the sidewalk is parallel and adjacent to a rigid structure, a 1/2" preformed joint filler (Non-extruding, Type B) shall be used. Sidewalk shall slope toward the street at a maximum of 1:50, and where necessary, may be depressed or sloped to fit alleys and entrances as shown on the plans or as directed by the Engineer. Where clear width of sidewalk between top of ramp and building or other obstruction is less than 48 inches, the slope of the flared sides shall not exceed 1:12. Where sidewalk is shown to be constructed back of an entrance it shall be 6" thick with welded wire mesh reinforcement of the same gauge and spacing of wires as in entrance pavement, as shown in the Reinforcement Diagram. Bid item will be 'Sidewalk Construction (6") either with or without air entrainment. Where the plans do not require air entrainment for sidewalk and sidewalk ramps, at the Contractor's option, Class A Concrete (AE) may be used throughout. Payment will be made as square yards of Sidewalk Construction. At the Contractor's option Class A Concrete (AE) may be used throughout for construction of steps, but payment will be made as Class A Concrete. Surface texture of the ramp shall be that obtained by a coarse brooming or steel tining transverse to the slope of the ramp and shall be sufficient to provide a ramp surface which contrasts with adjacent surfaces.

\* Wheel Chair Ramps shall be constructed per City of Wichita Detail. See Sheet 60.

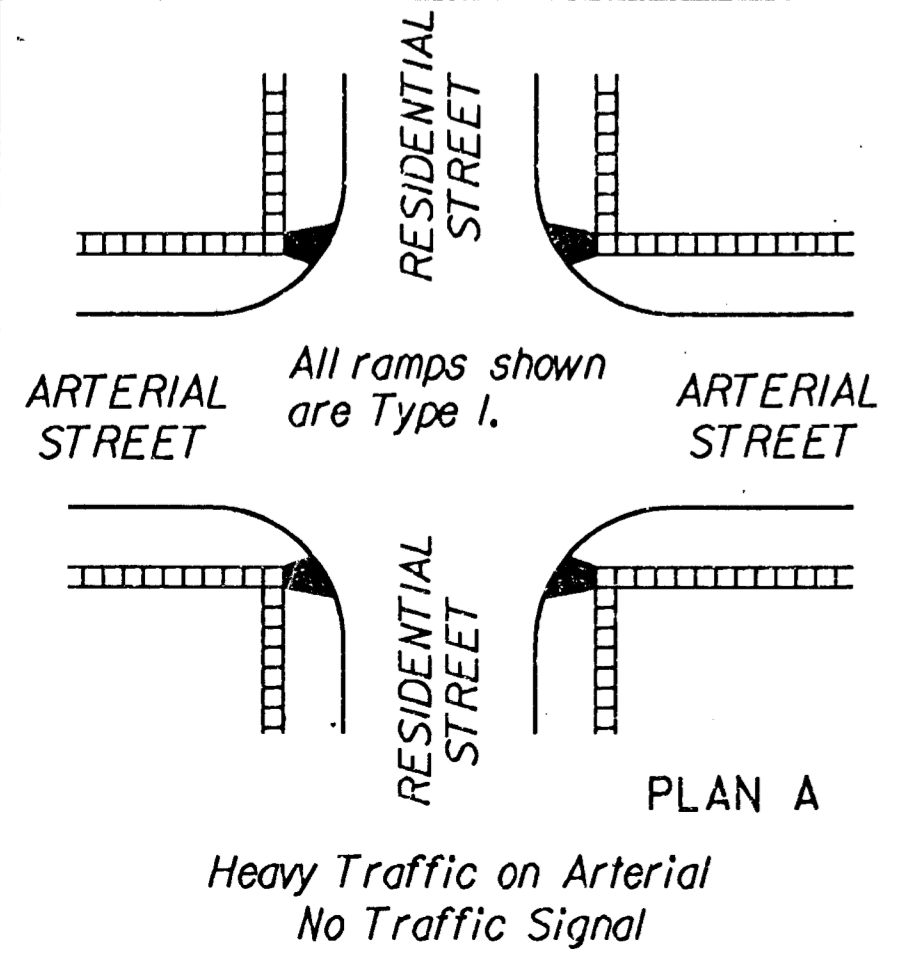

PLAN A

Heavy Traffic on Arterial  
No Traffic Signal

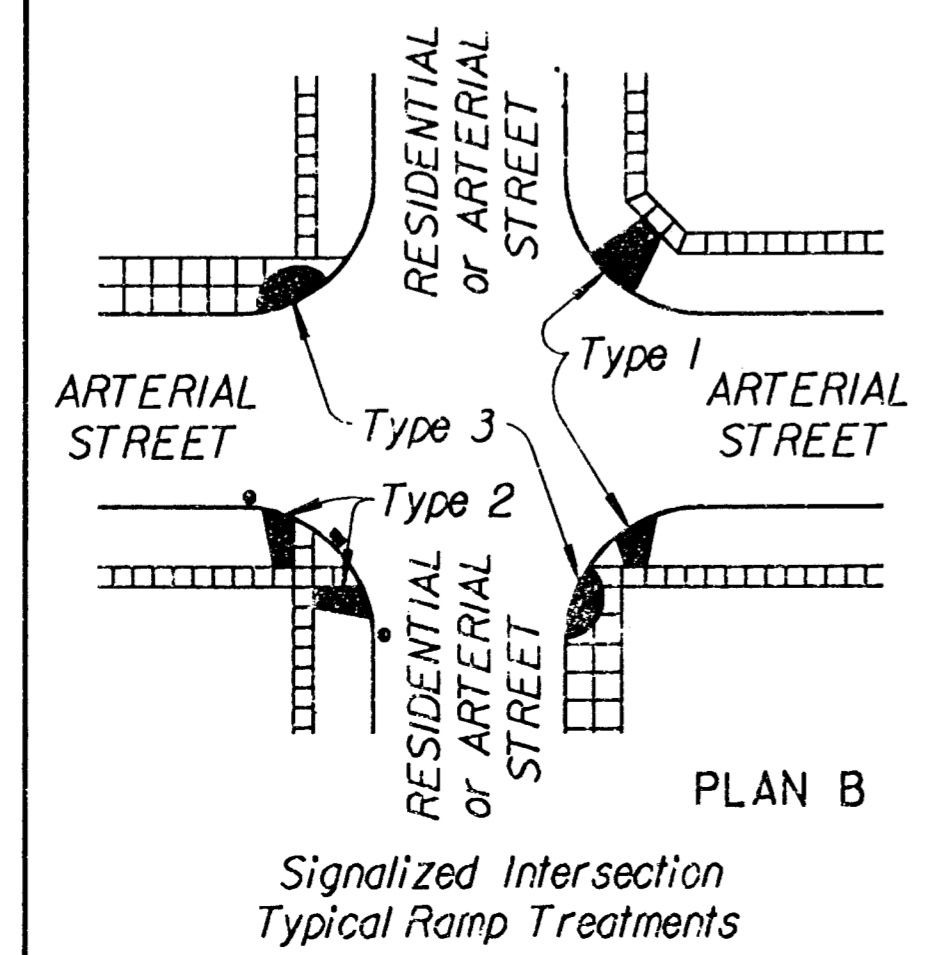

PLAN B

Signalized Intersection  
Typical Ramp Treatments

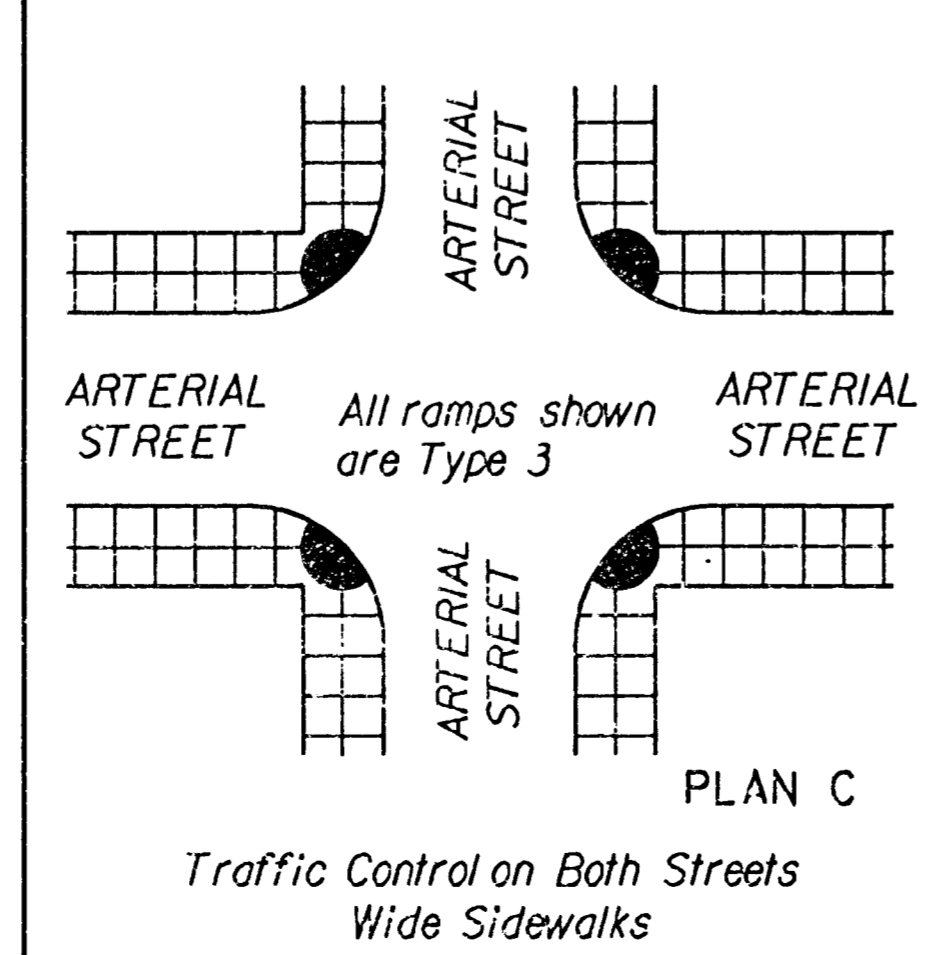

PLAN C

Traffic Control on Both Streets  
Wide Sidewalks

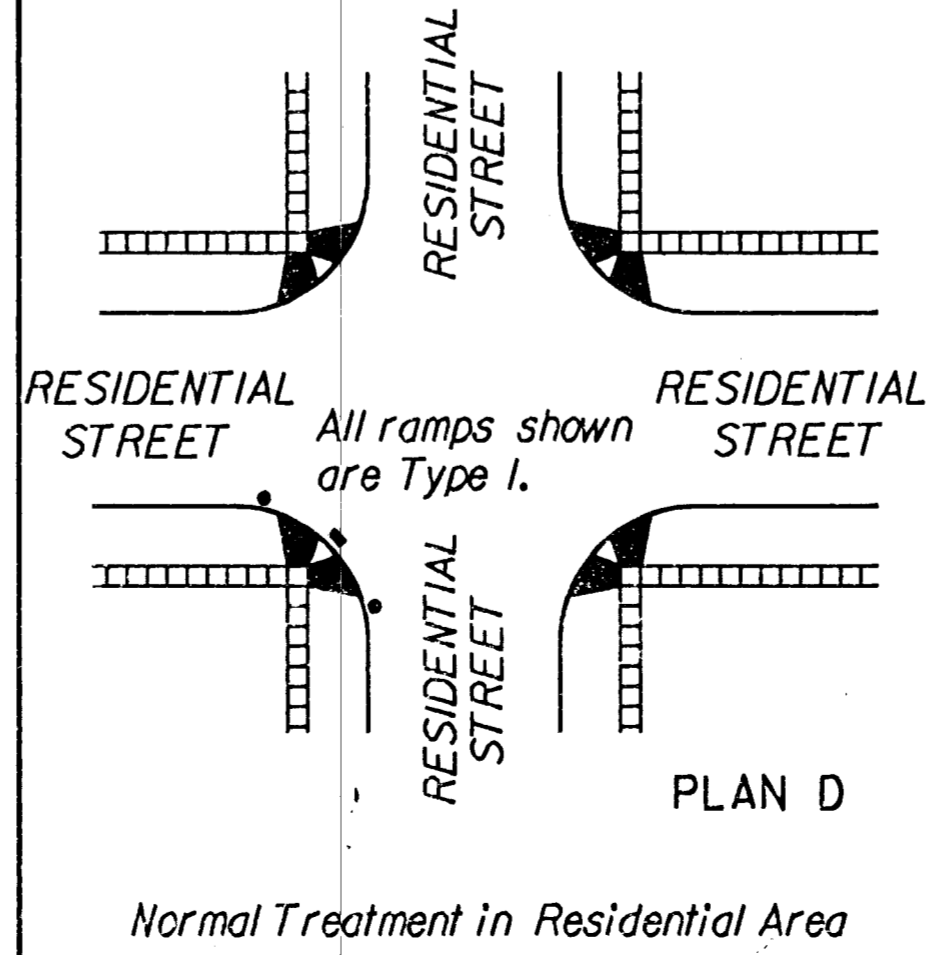

PLAN D

Normal Treatment in Residential Area

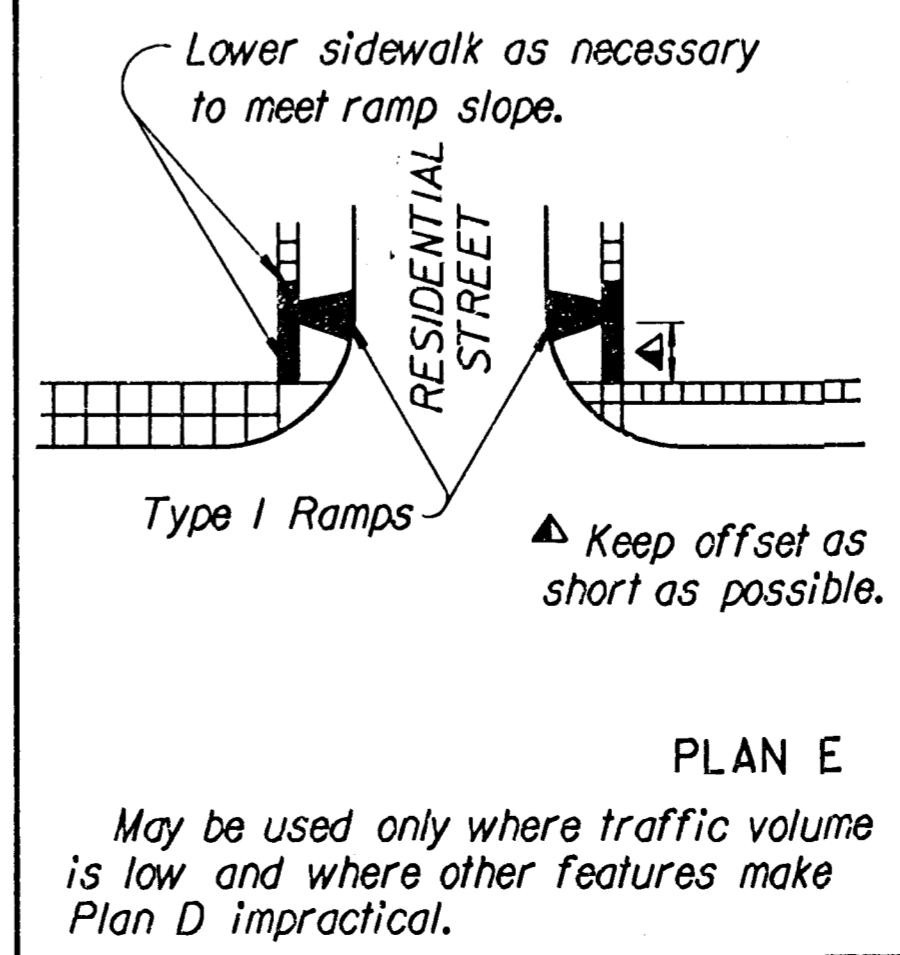

PLAN E

Lower sidewalk as necessary to meet ramp slope.  
Type I Ramps  
Keep offset as short as possible.  
May be used only where traffic volume is low and where other features make Plan D impractical.

LEGEND			
Sidewalk Ramp Type 1			
Sidewalk Ramp Type 2			
Sidewalk Ramp Type 3			
Preferred location of drainage inlet (Typical)			
Alternate location of drainage inlet (Typical)			
Sidewalk			

KANSAS DEPARTMENT OF TRANSPORTATION			
SIDEWALK & STEPS			
STD. NO. 725			
DESIGNED	10-24-91	Revised maximum ramp slopes	R.J.S. J.O.B.
DESIGN CK.	9-2-88	5' Min. sidewalk width, ent. on CADD	R.J.S. J.O.B.
APP'D		QUANTITIES	TRACED BOWSER
		DETAIL CK.	TRACE CK. SEITZ