

**BENCHMARK:**  
 BM #1: WEST OF INTERSECTION OF  
 MAIZE ROAD & 31ST STREET SOUTH,  
 CITY OF WICHITA BENCHMARK DISK,  
 SOUTHEAST CORNER OF HUBGUARD OF  
 R.C.B.C., 330.9' WEST & 16.8' SOUTH  
 OF THE NE COR., NE 1/4, SEC. 7, TWP.  
 28-S, R-1-W. ELEV. = 1331.90  
 NAVD88

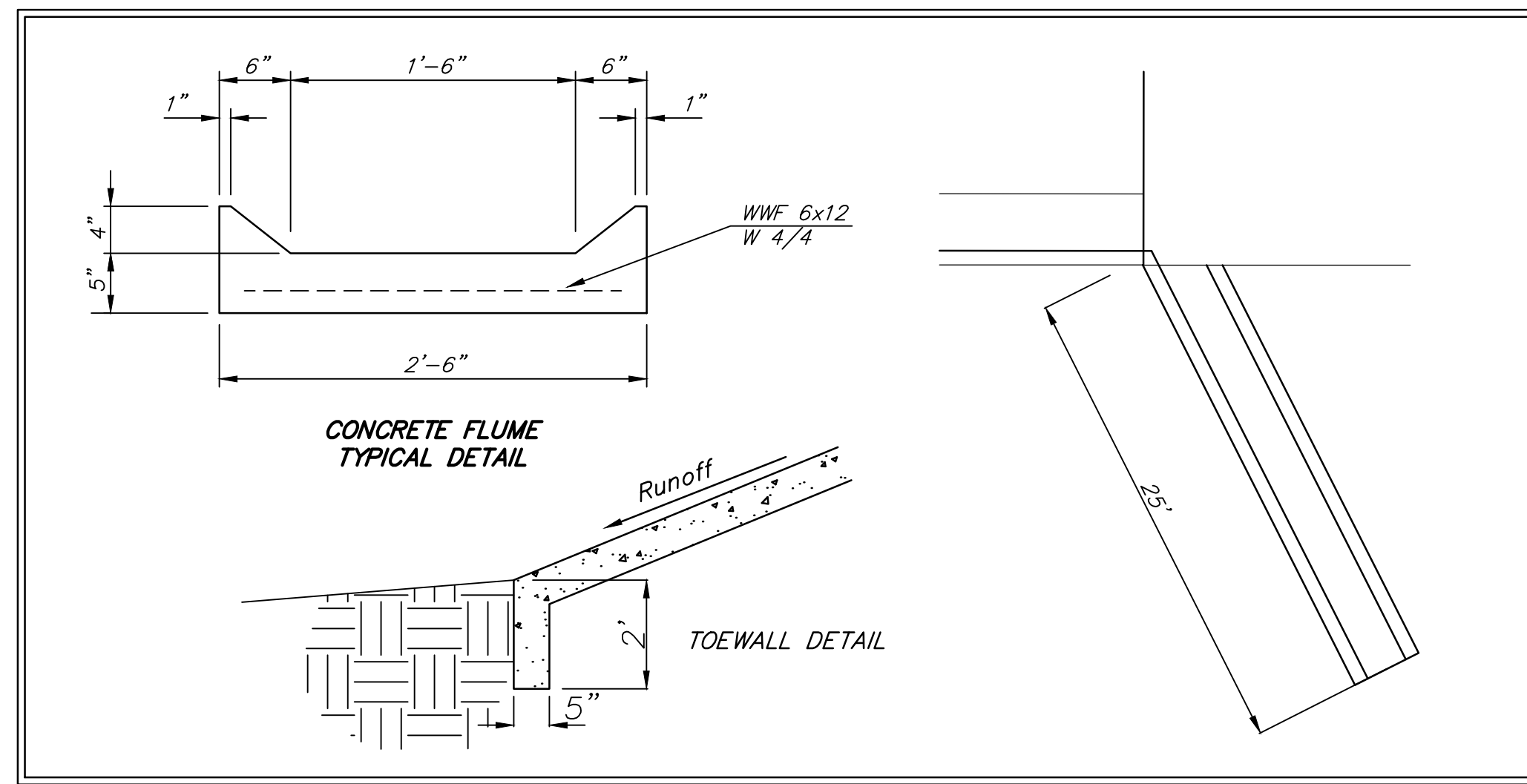
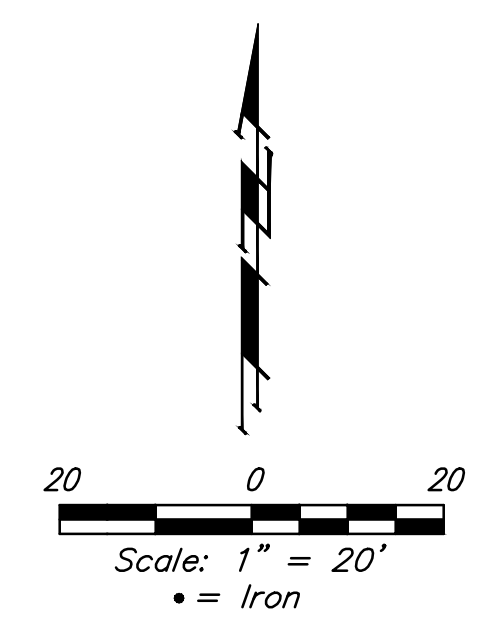
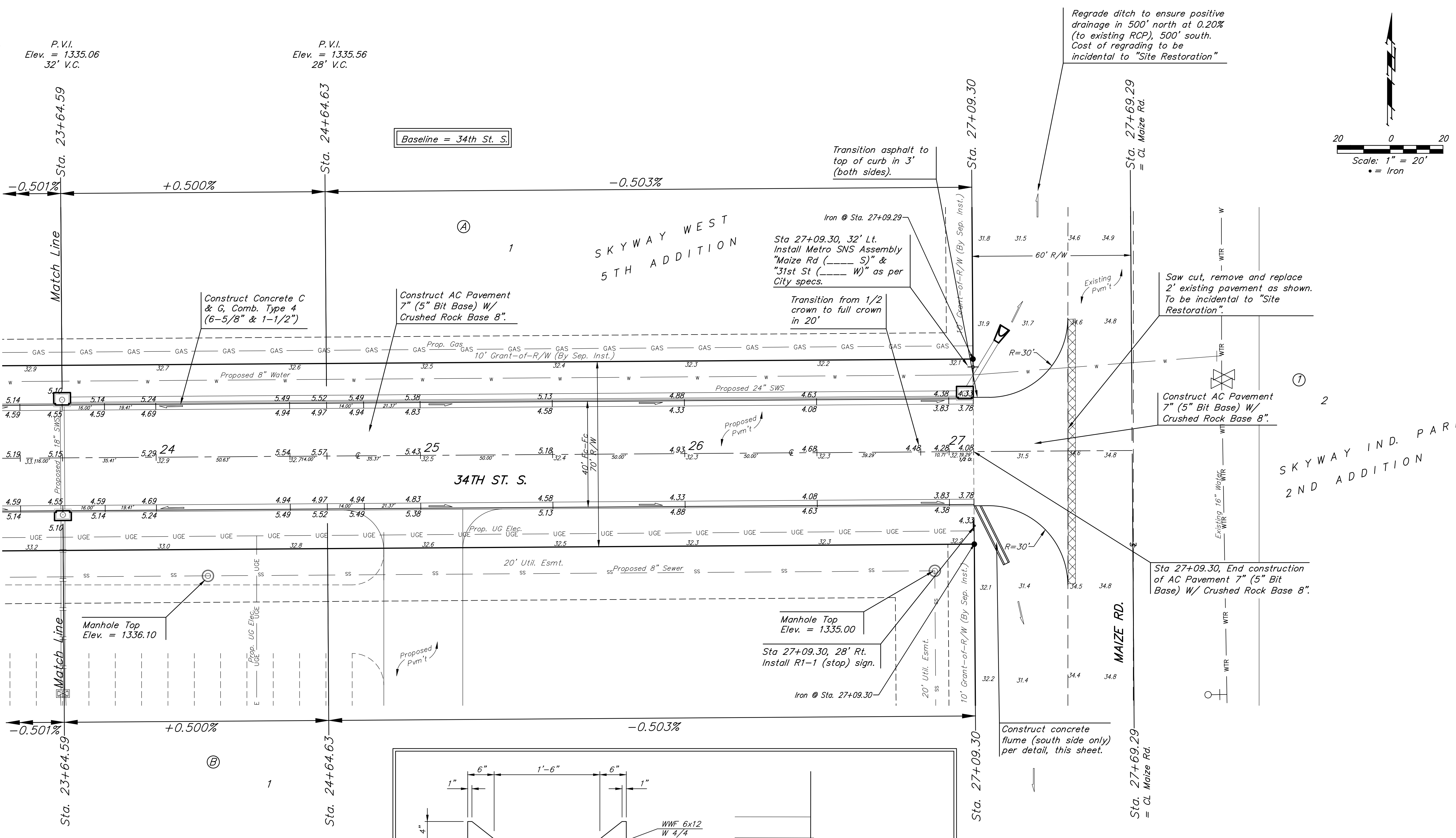

**Baughman Company, P.A.**  
 P.E. W. J. BAUGHMAN, P.E. J. BAUGHMAN, P.E. J. BAUGHMAN, P.E.  
 ENGINEERING, ARCHITECTURE, PLANNING, LANDSCAPE ARCHITECTURE  
 1000 W. 12TH ST., SUITE 100, WICHITA, KS 67202  
 (316) 261-1111  
 www.baughman.com

SKYWAY WEST 5TH ADD. - PH 1  
**34TH ST. S.**  
 STA. 23+64.59 TO STA. 27+09.29