

**EXPANSION JOINT**

NOTE: Extra Thickness to be Subsidiary to Price of Square Yards Pavement

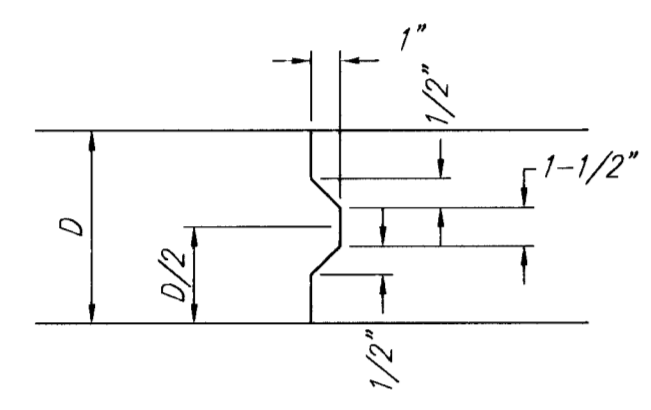

**KEYWAY DETAIL**

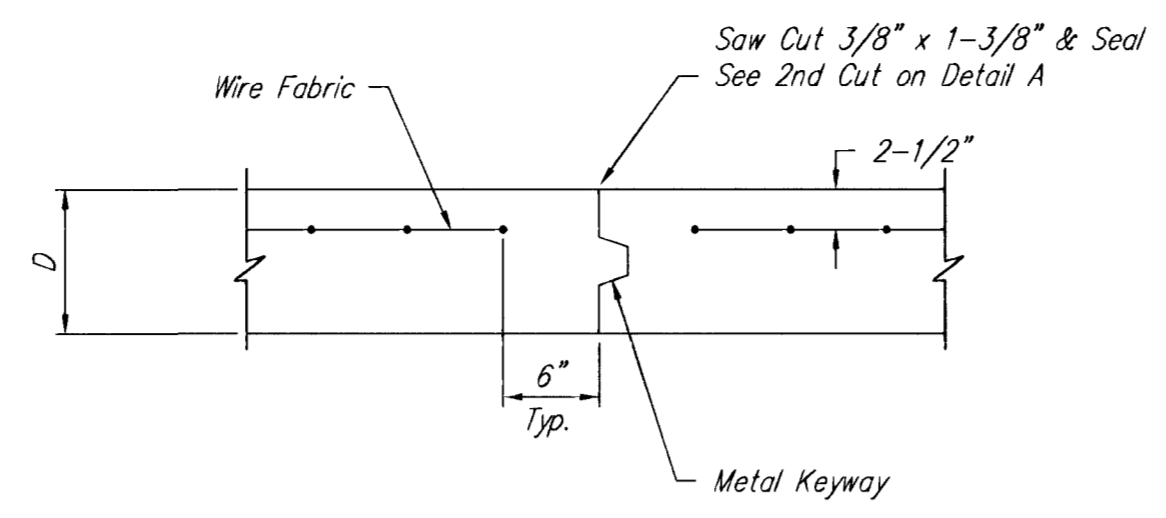

**OPTIONAL CONTRACTION JOINT**

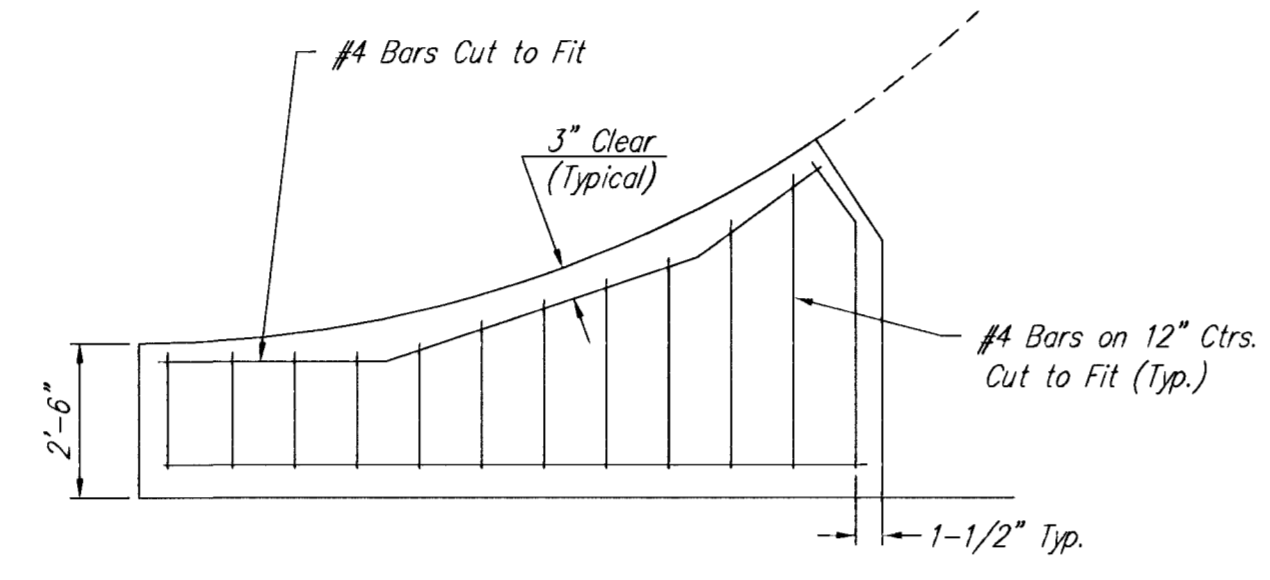

**WING REINFORCING DETAIL**

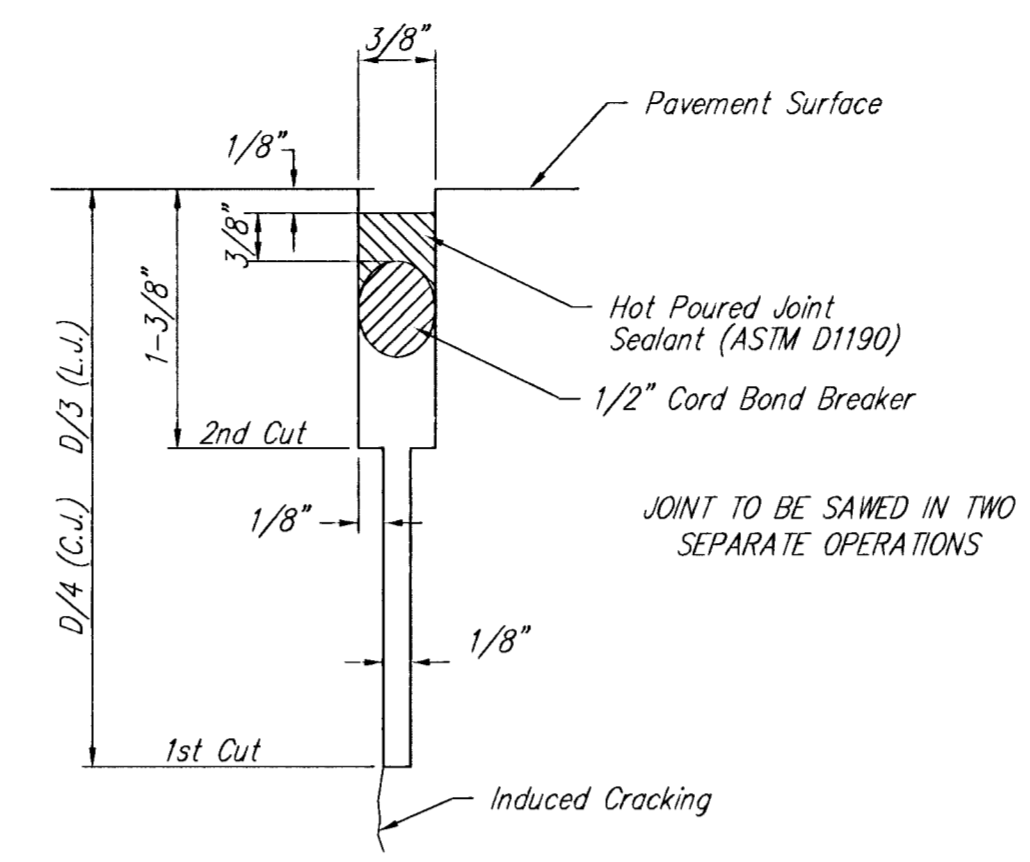

**SAW JOINT DETAIL**

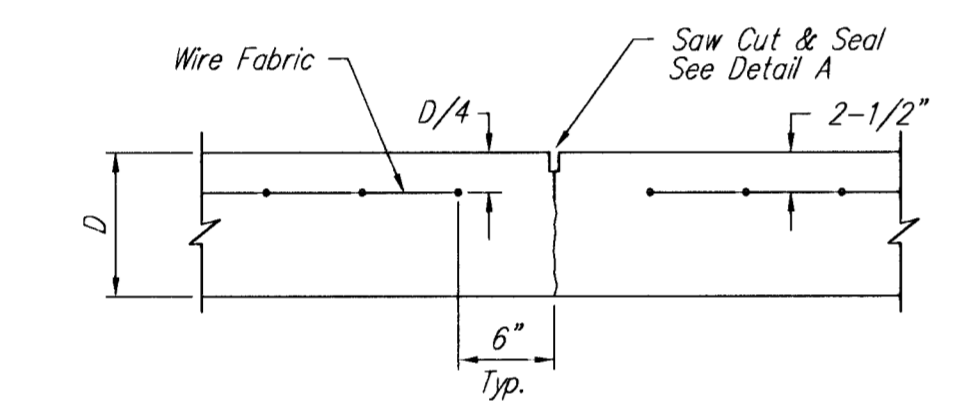

**CONTRACTION JOINT DETAIL (C.J.)**

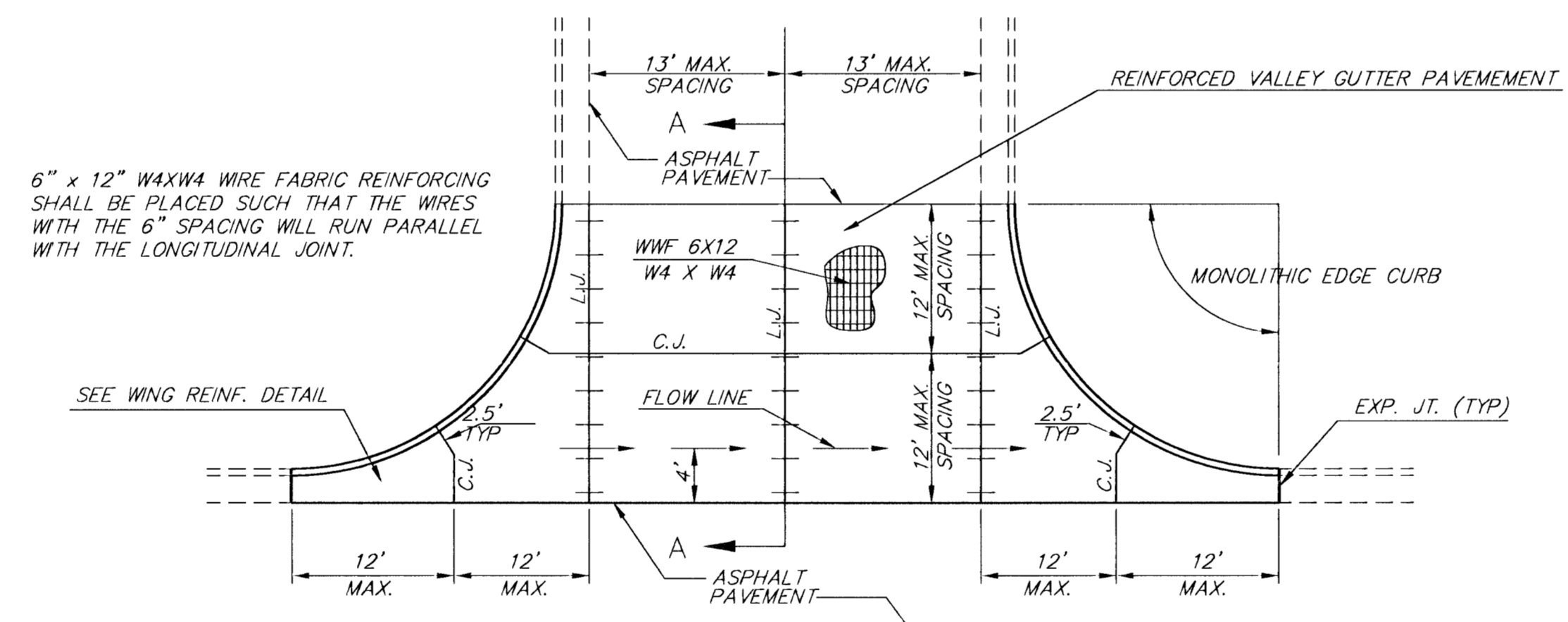

**PLAN**

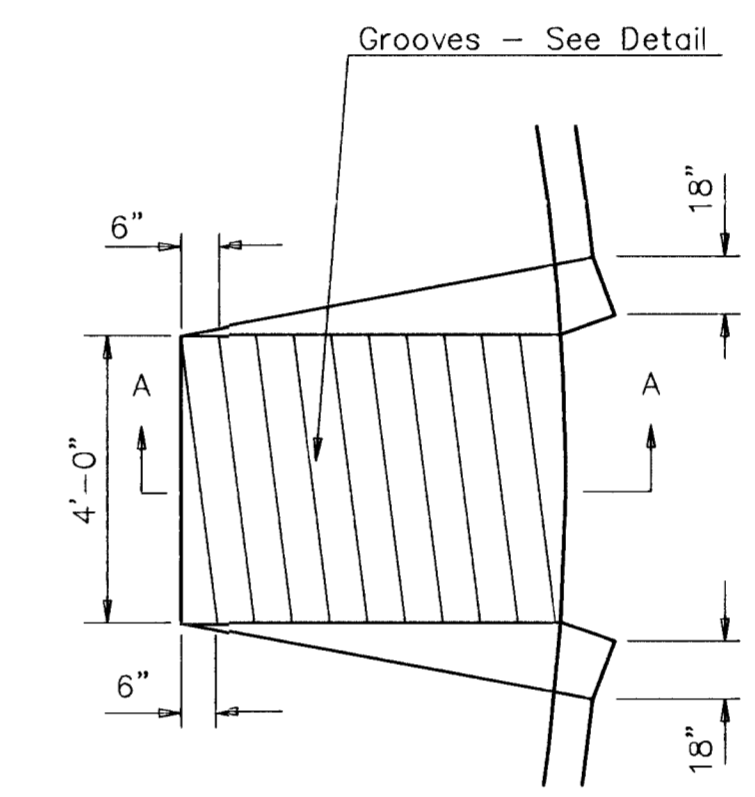

**WHEELCHAIR RAMP PLAN VIEW**

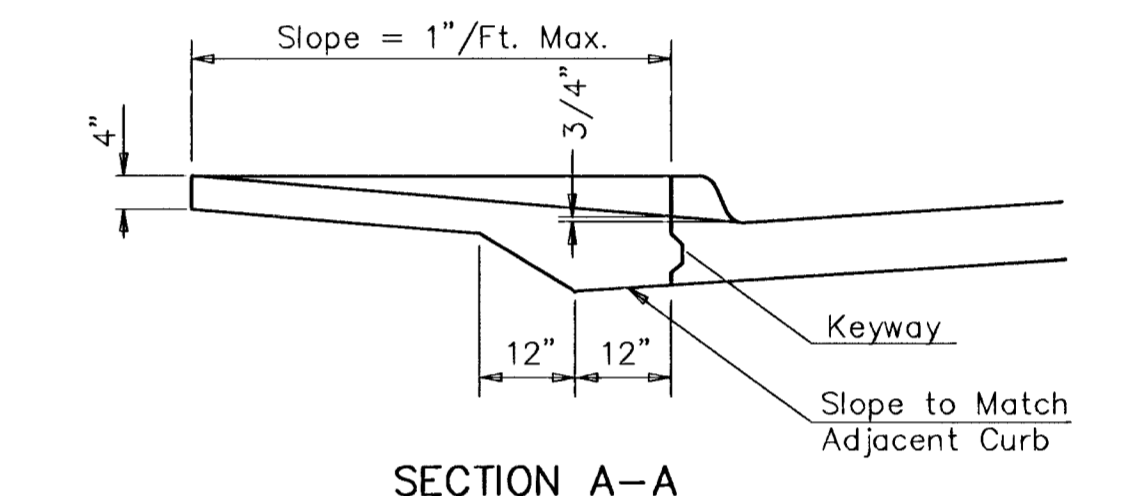

**SECTION A-A**

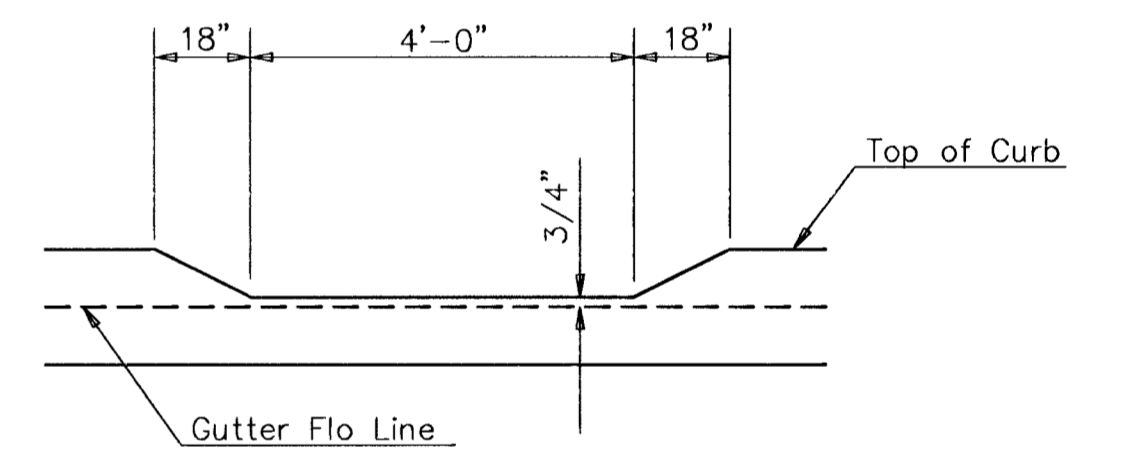

**DEPRESSED CURB DETAIL**

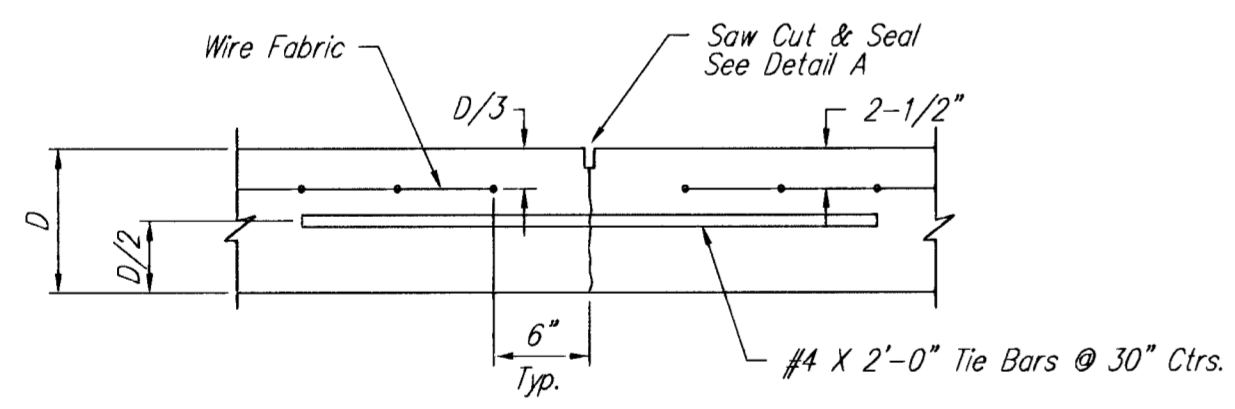

**LONGITUDINAL JOINT DETAIL (L.J.)**

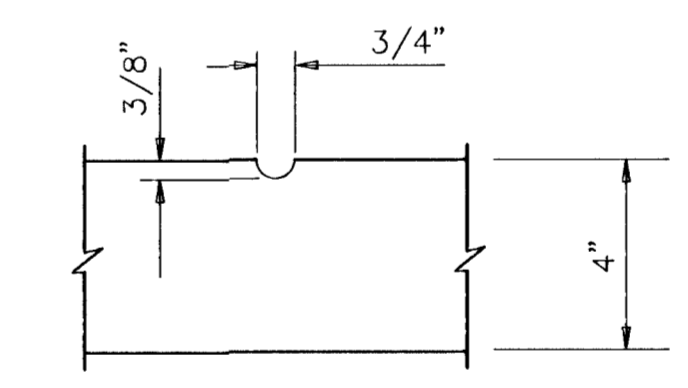

**GROOVE DETAIL**

**WHEELCHAIR RAMP DETAIL**

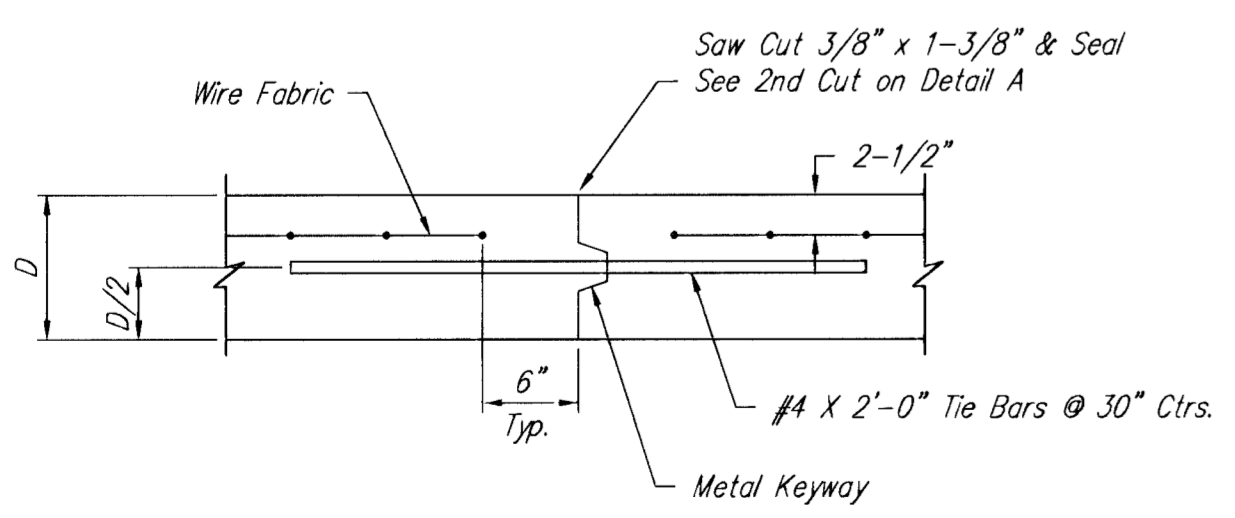

**OPTIONAL LONGITUDINAL JOINT DETAIL (L.J.)**

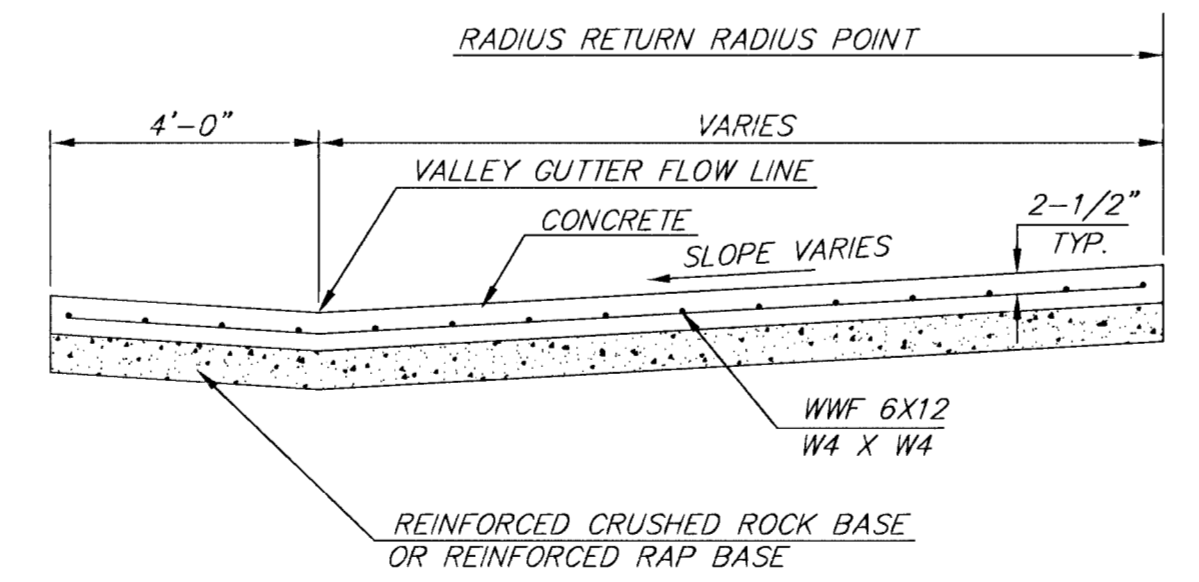

**SECTION A-A**

**REINFORCED VALLEY GUTTER DETAIL**

<p>THE CITY OF WICHITA</p>	<b>VALLEY GUTTER DETAILS</b>	
	<b>WHEELCHAIR RAMP DETAILS</b>	
	M. E. LINDEBAK P.E. - CITY ENGINEER	
	PROJECT NUMBER 87 N-0092-01	INDEX CODE XXXXXX
DATE MAR 96	SHEET 16A OF 75	

\\wv11p1\cnc\1827\val\gudt.dwg Fr, Jan 21 10:25:08 2000 JULIE