

EXPANSION JOINT

NOTE: Extra Thickness to be Subsidiary to Price of Square Yards Pavement

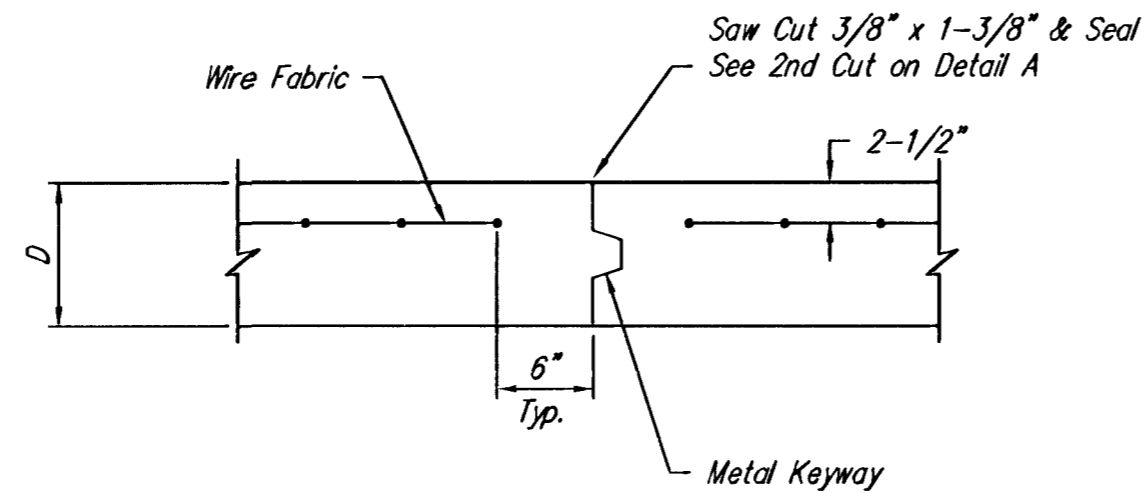

OPTIONAL CONTRACTION JOINT

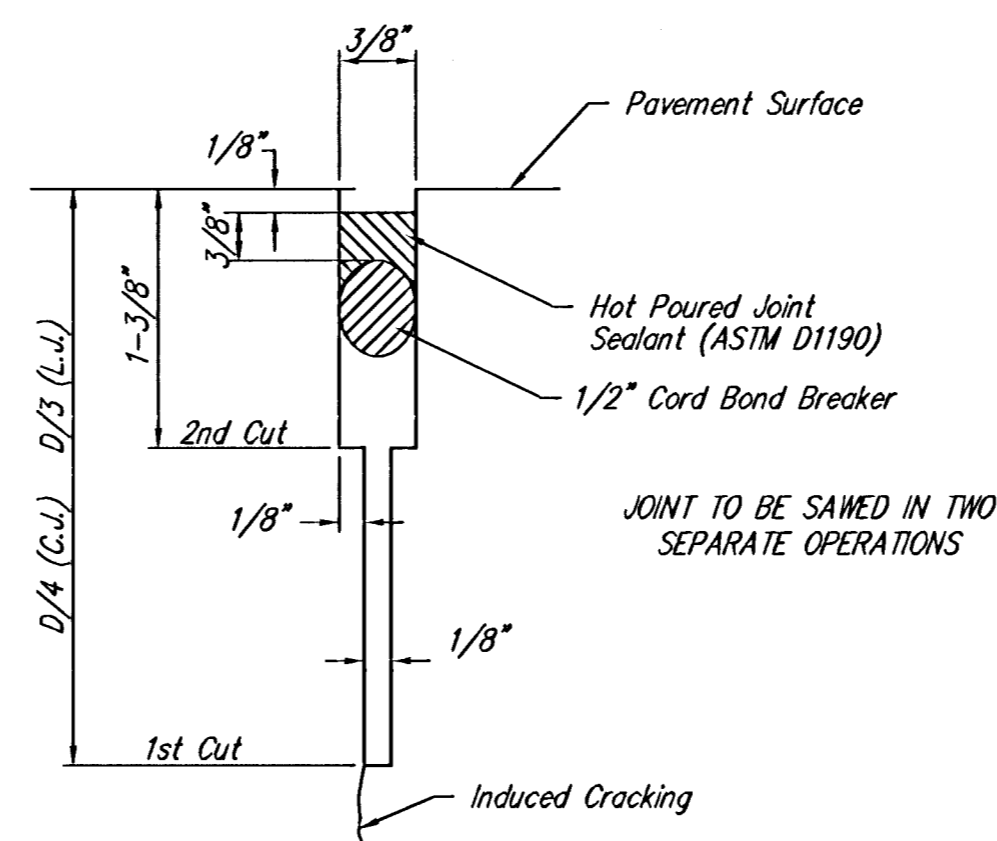

SAW JOINT DETAIL

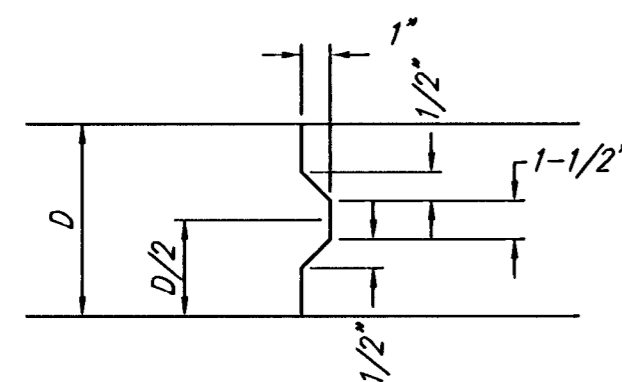

KEYWAY DETAIL

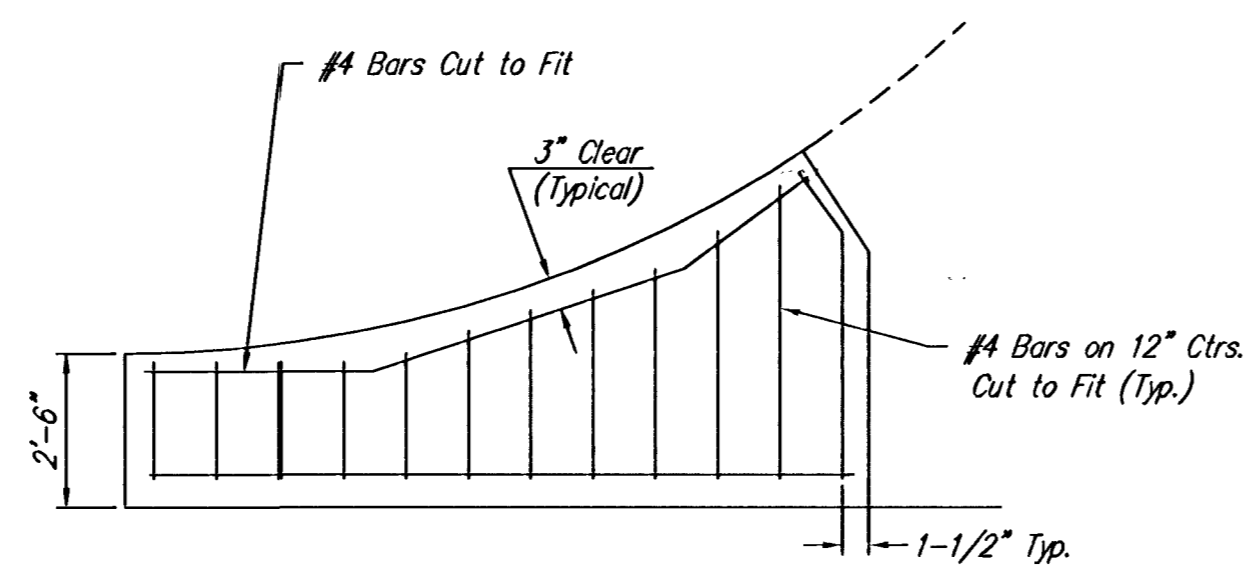

WING REINFORCING DETAIL

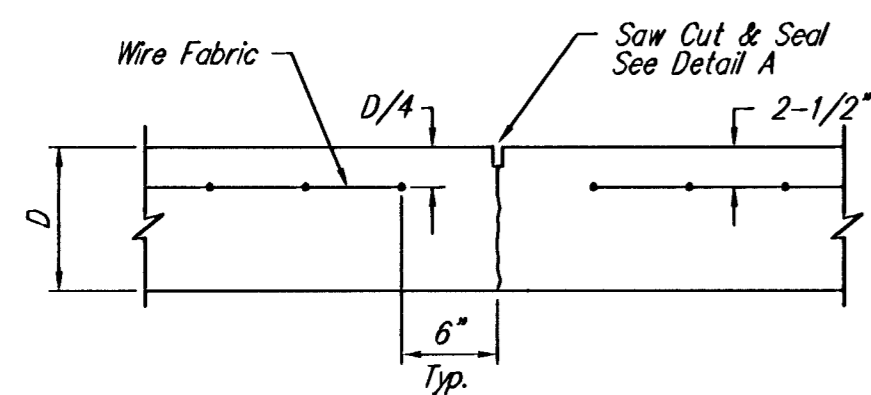

CONTRACTION JOINT DETAIL (C.J.)

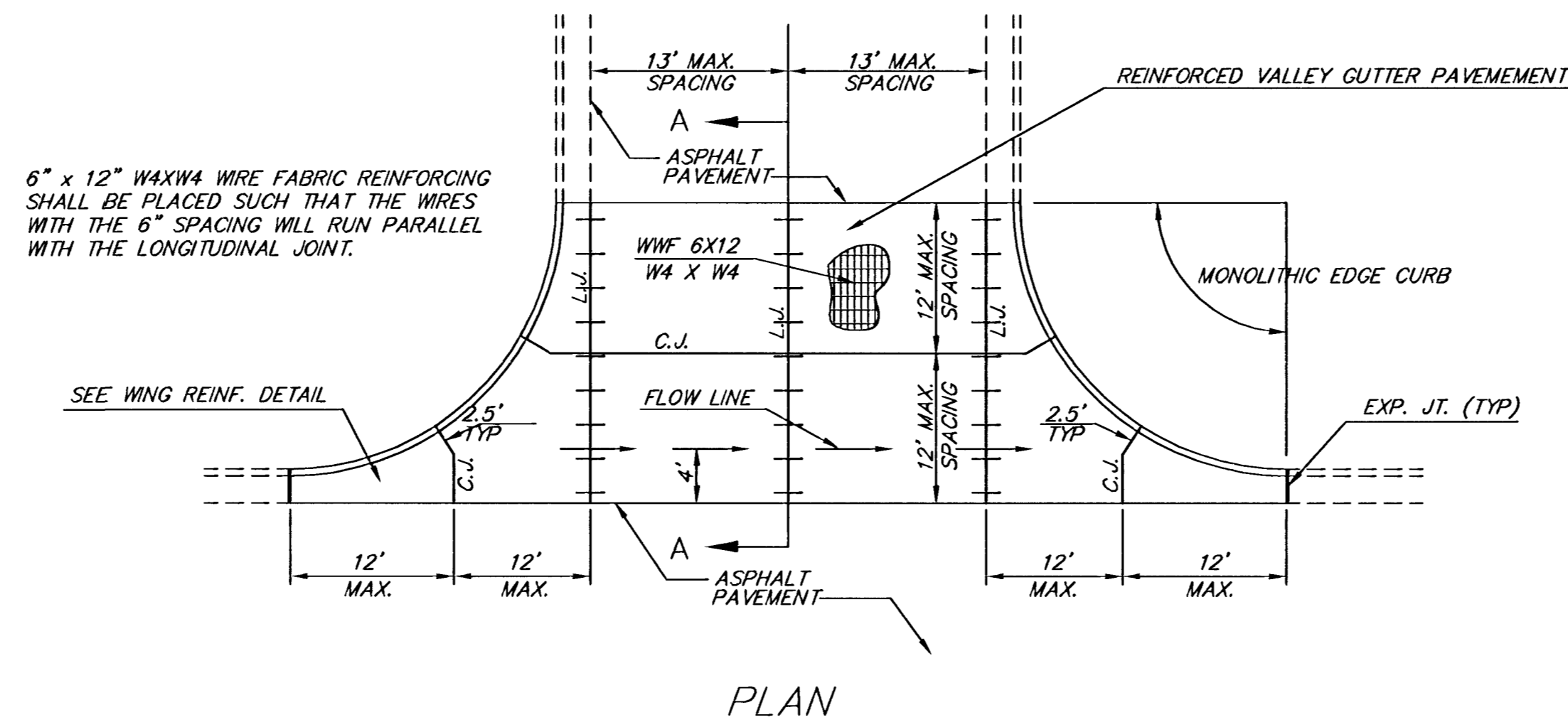

PLAN

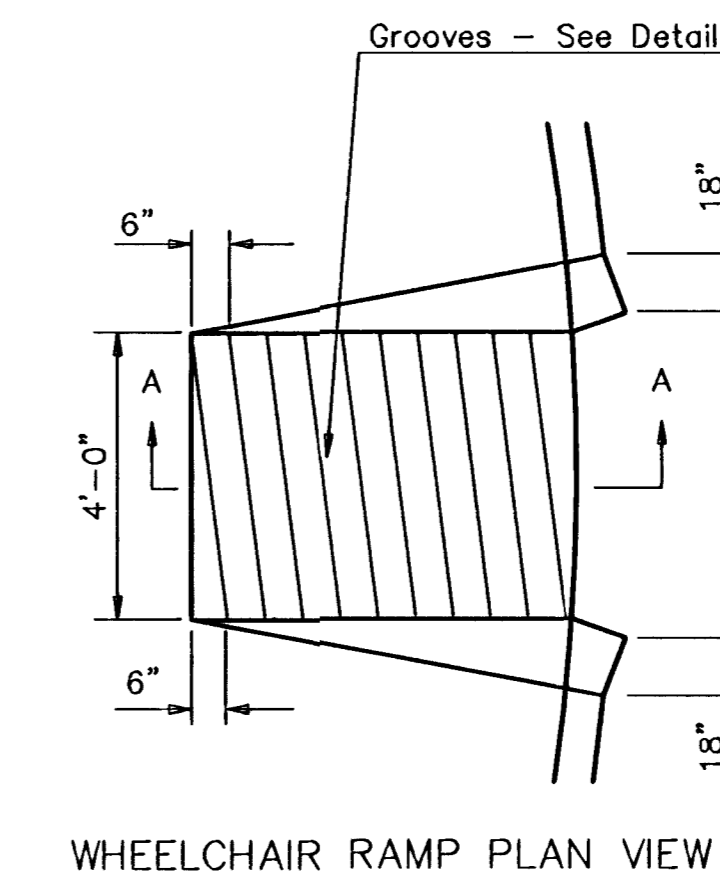

WHEELCHAIR RAMP PLAN VIEW

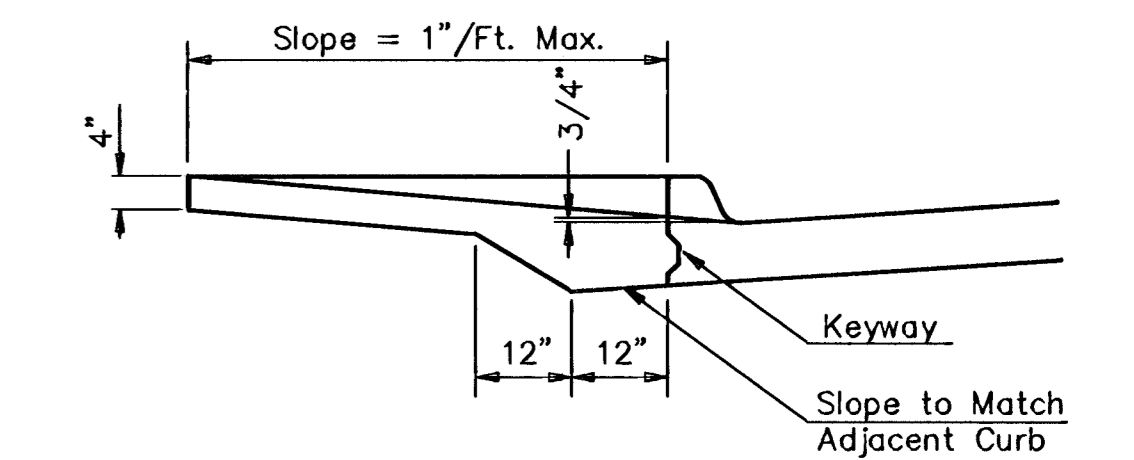

SECTION A-A

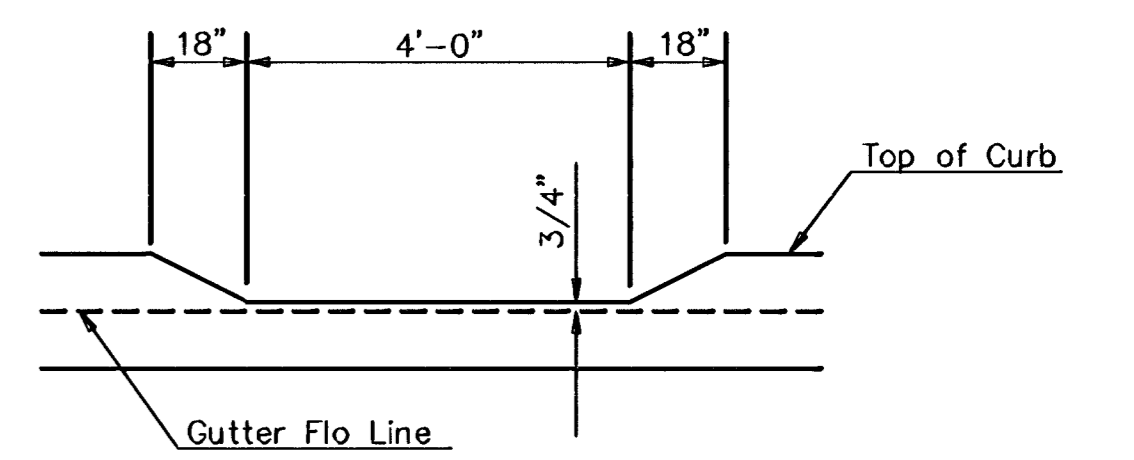

DEPRESSED CURB DETAIL

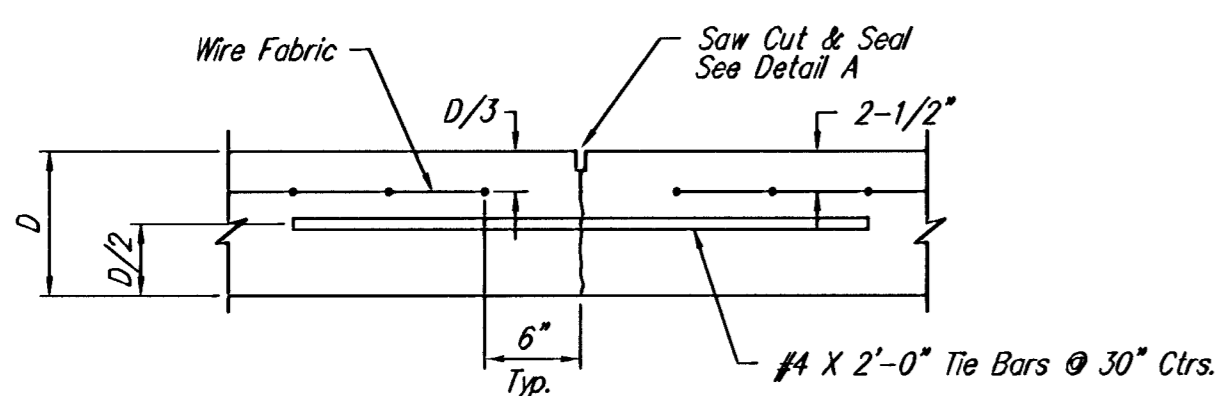

LONGITUDINAL JOINT DETAIL (L.J.)

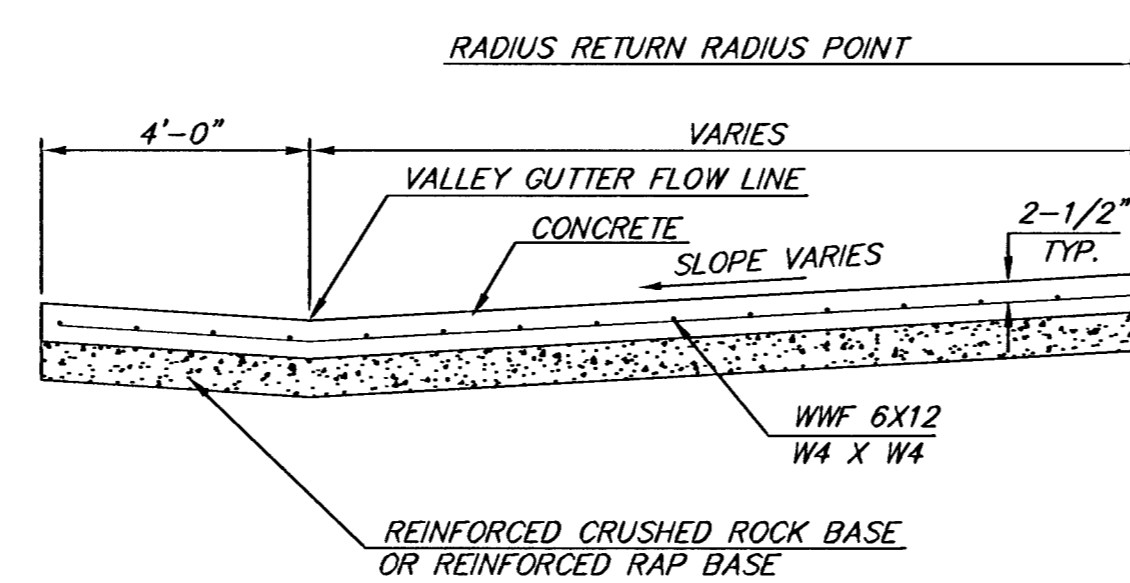

SECTION A-A

REINFORCED VALLEY GUTTER DETAIL

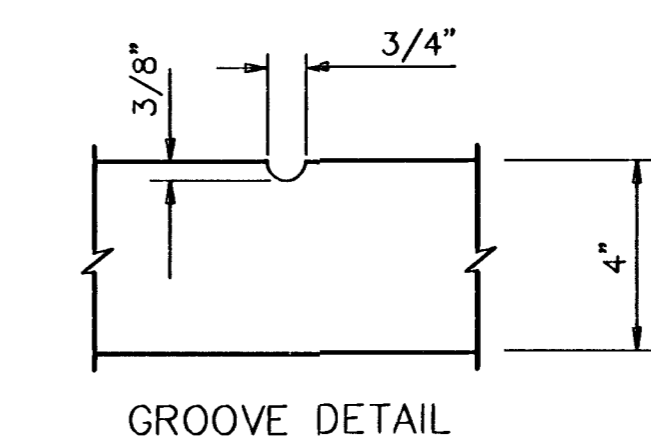

GROOVE DETAIL

WHEELCHAIR RAMP DETAIL

OPTIONAL LONGITUDINAL JOINT DETAIL (L.J.)

H:\CIVIL\02121\Draw\Phase 1A\VALGUT.dwg 03/05/2003 11:22:59 AM CST

<p>THE CITY OF WICHITA</p> <p>CITY ENGINEER'S OFFICE 455 NORTH MAIN STREET WICHITA, KANSAS 67202 (316) 268-4501 (316) 268-4114 FAX</p>	<p>VALLEY GUTTER DETAILS</p> <p>WHEELCHAIR RAMP DETAILS</p>	
	<p>NEIL D. CABLE, P.E. - CITY ENGINEER</p>	
	<p>PROJECT NUMBER XXX-XXXX</p>	<p>INDEX CODE XXXXXX</p>
	<p>DATE MAR 96</p>	<p>SHEET 4 OF 34</p>