

WHEELCHAIR RAMP DETAIL

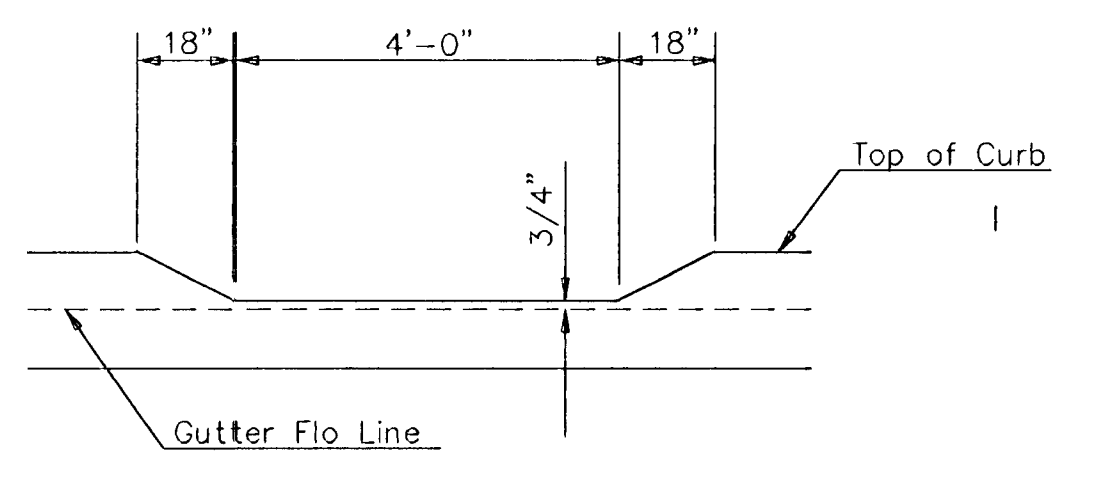

DEPRESSED CURB DETAIL

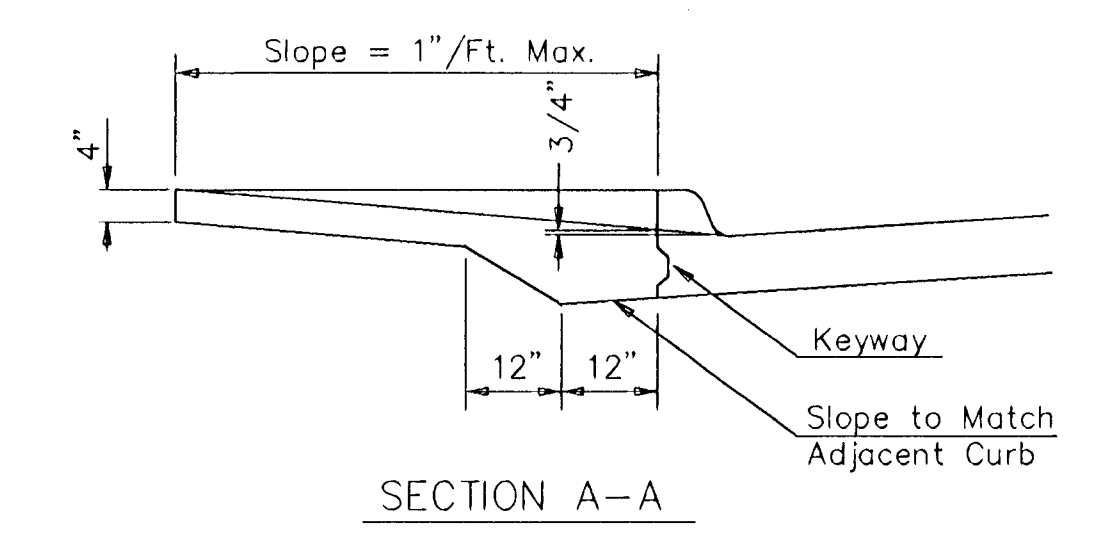
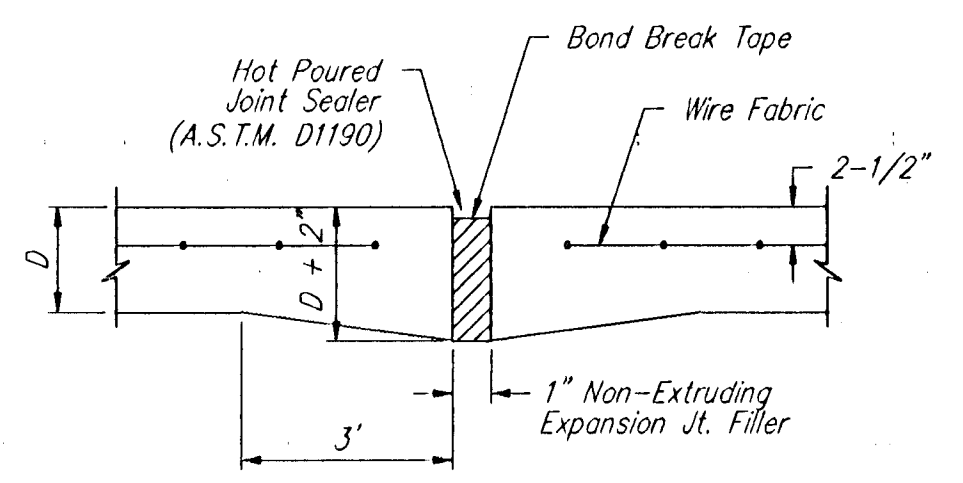

EXPANSION JOINT

NOTE: Extra Thickness to be Subsidiary to Price of Square Yards Pavement

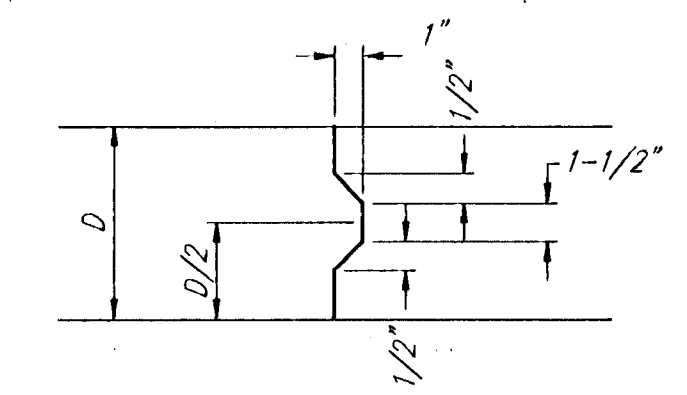

KEYWAY DETAIL

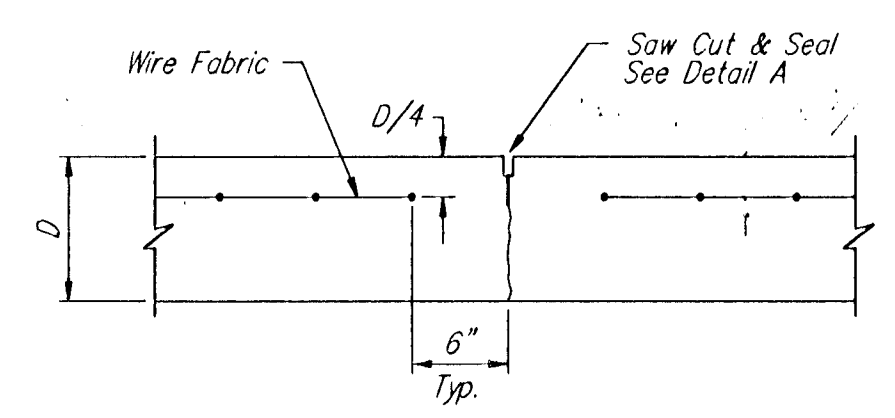

CONTRACTION JOINT DETAIL (C.J.)

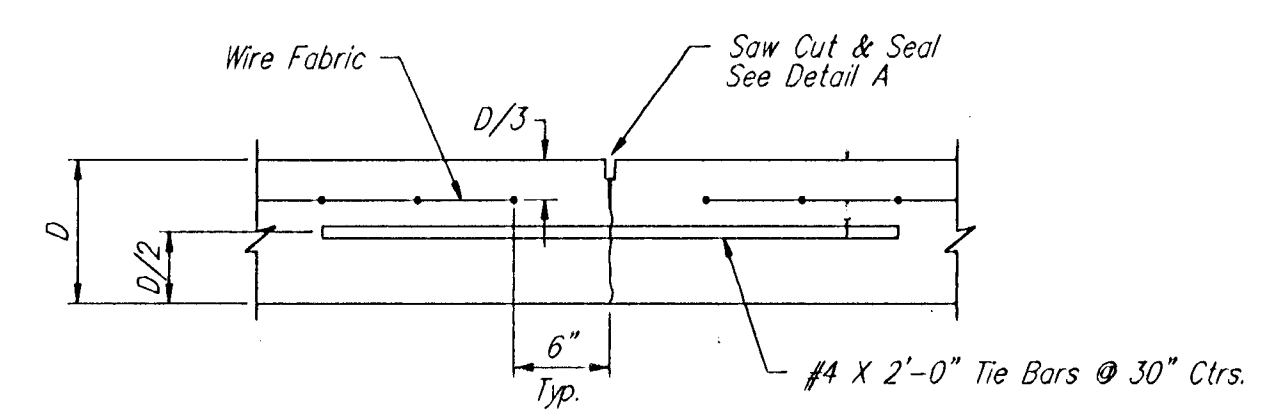

LONGITUDINAL JOINT DETAIL (L.J.)

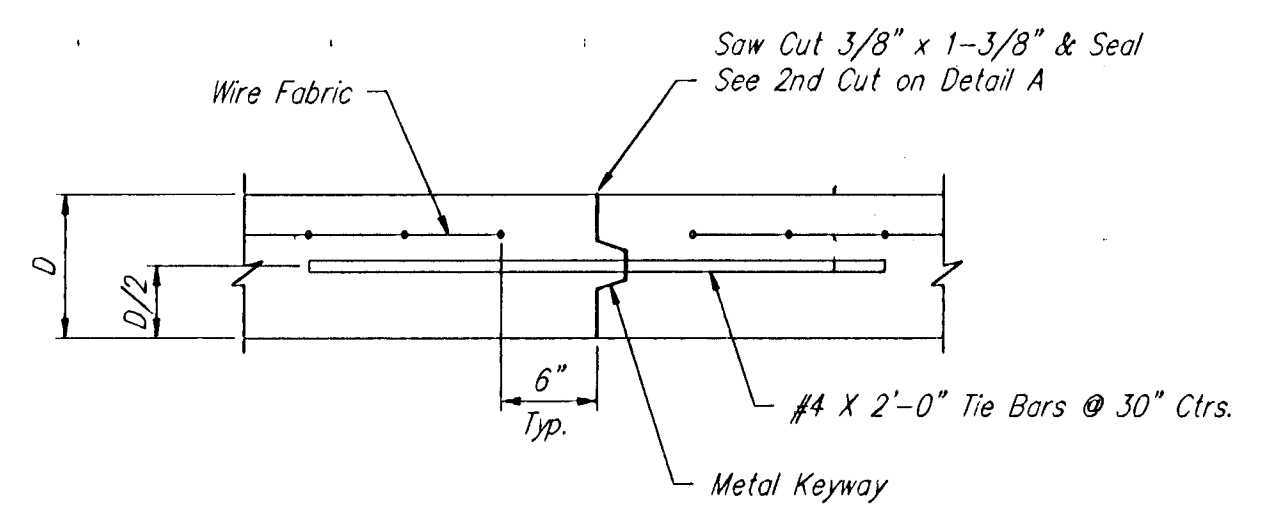

LONGITUDINAL JOINT DETAIL (L.J.)

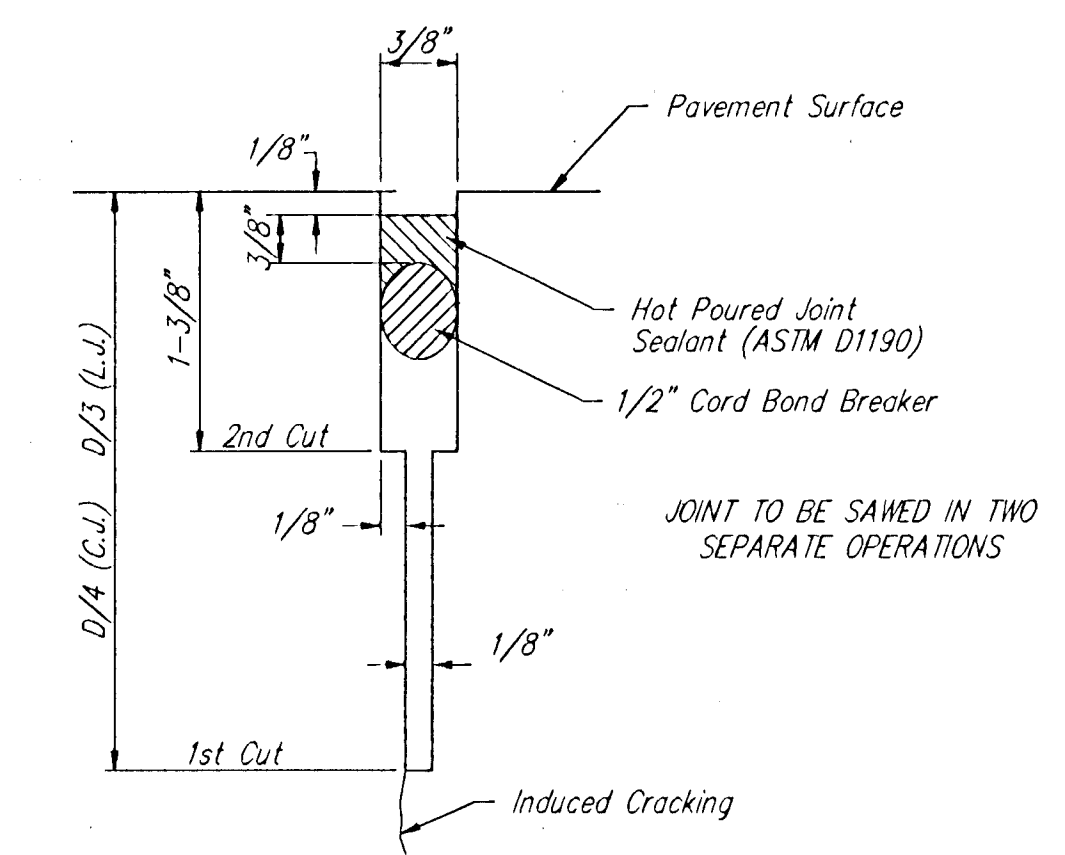

SAW JOINT DETAIL

JOINT TO BE SAWED IN TWO SEPARATE OPERATIONS

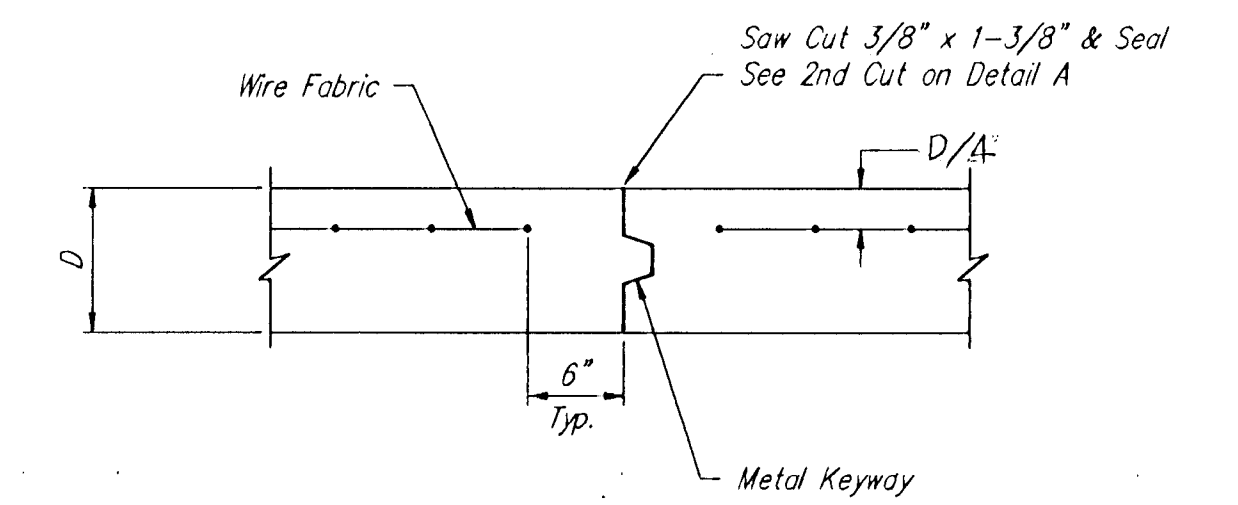

OPTIONAL CONTRACTION CONST. JOINT (C.J.)

(ALTERNATE C.J.)

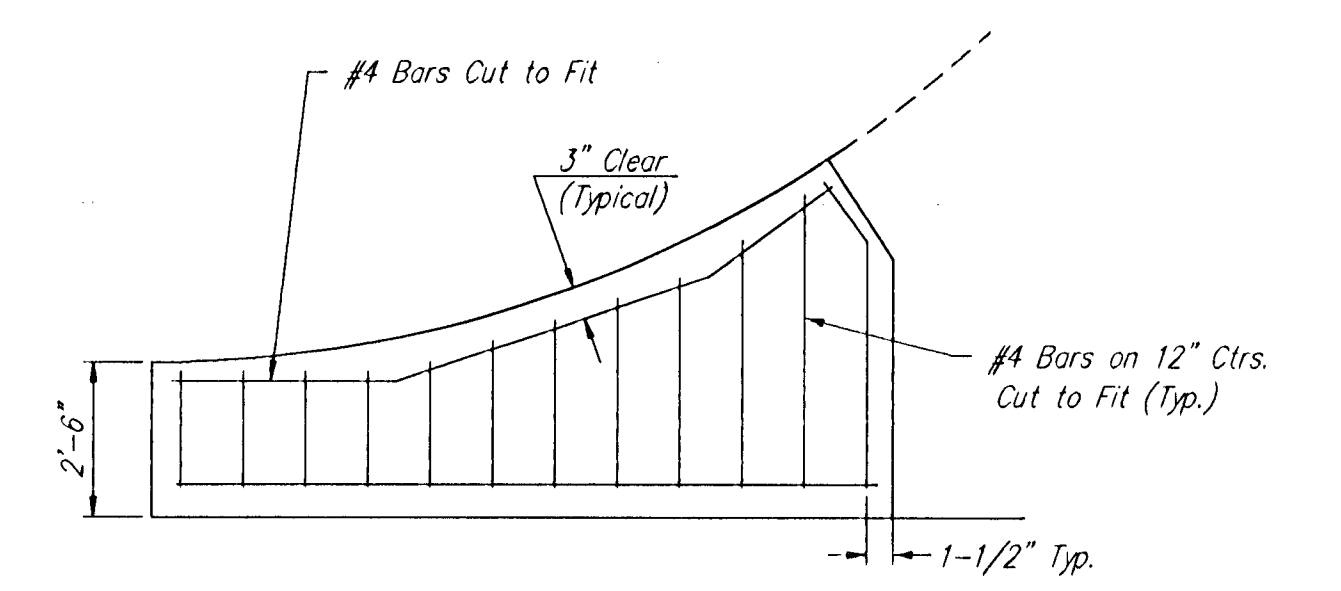

WING REINFORCING DETAIL

(USE WITH ASPHALTIC CONCRETE PAVEMENT ALTERNATE)

<b>VALLEY GUTTER DETAILS</b>				REV.
 <b>BAUGHMAN COMPANY P. A.</b> ENGINEERING & SURVEYING 316/262-7271 • 315 ELLIS • WICHITA, KANSAS 67211				
PROJECT NUMBER				SHEET
<b>074 PPP (607879)</b>				<b>4</b>
DESIGN	DRAWN	APPROVED	DATE	SCALE
CMB\TCR	CMB\JL		10-1-92	1" = 20'
				OF <b>11</b>

town\vg