

EXPANSION JOINT

NOTE: Extra Thickness to be Subsidiary to Price of Square Yards Pavement

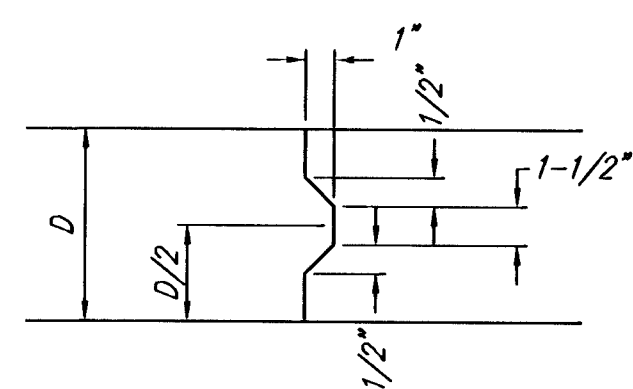

KEYWAY DETAIL

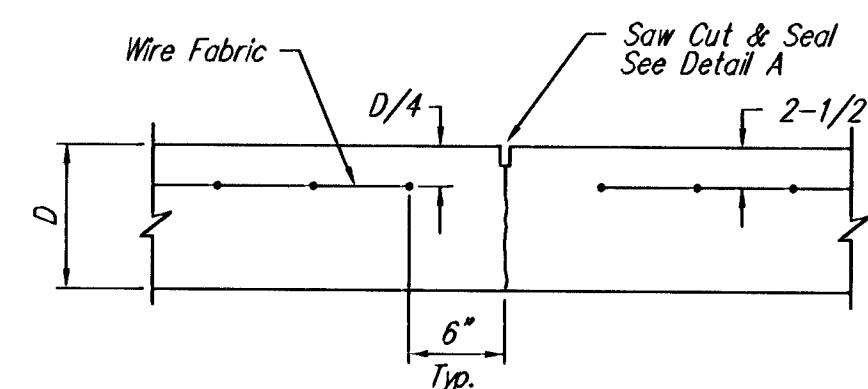

CONTRACTION JOINT DETAIL (C.J.)

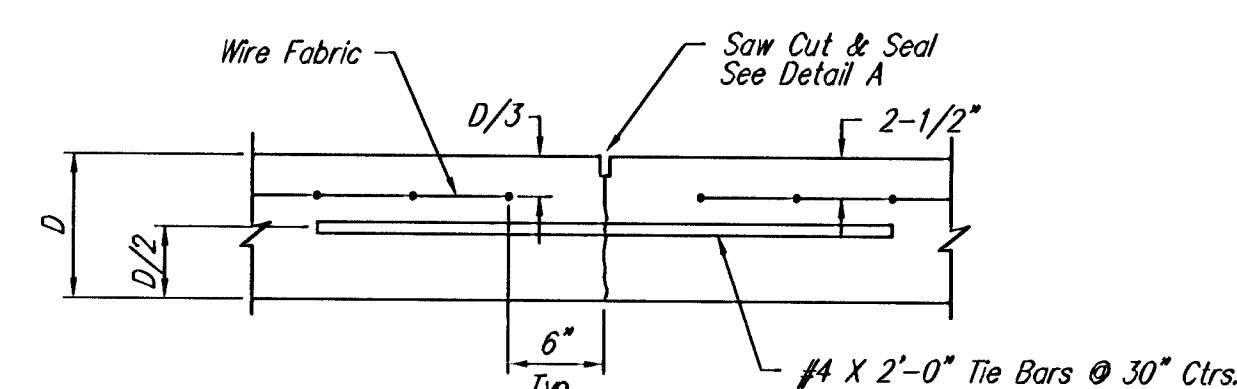

LONGITUDINAL JOINT DETAIL (L.J.)

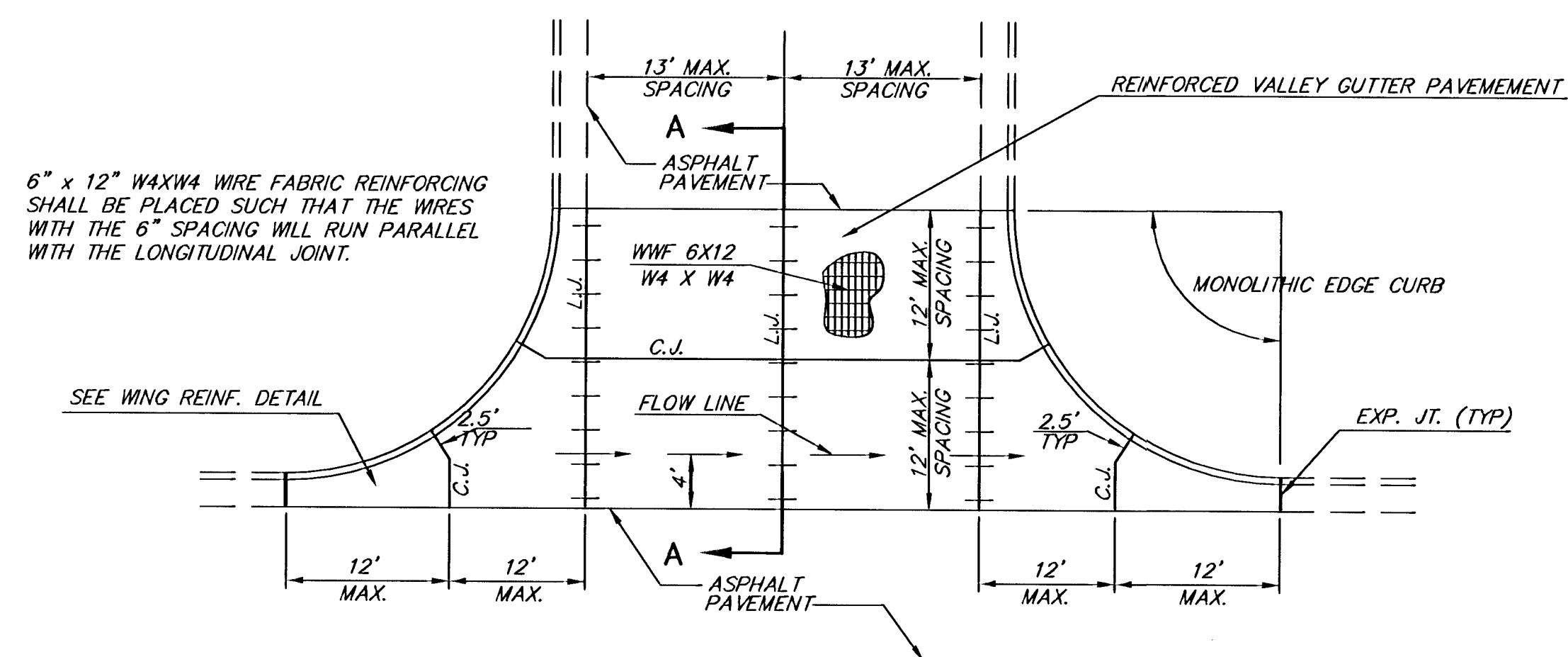

PLAN

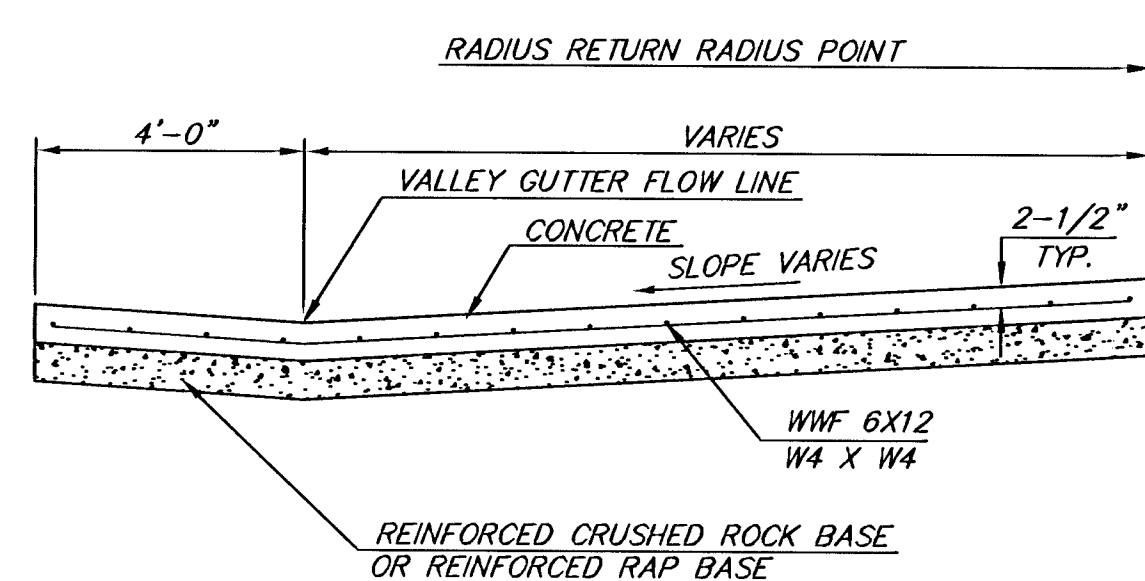

SECTION A-A

REINFORCED VALLEY GUTTER DETAIL

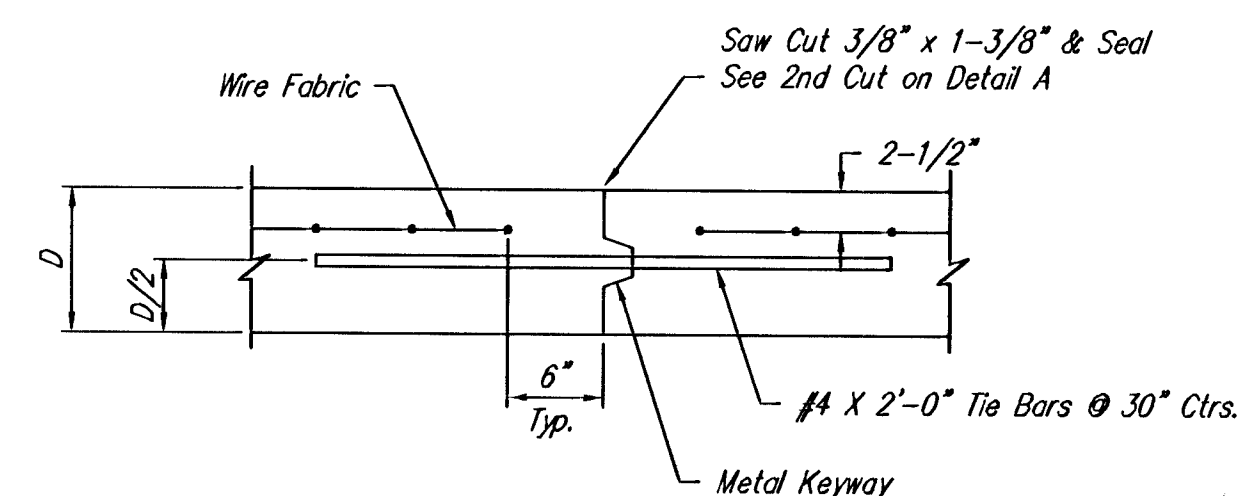

OPTIONAL LONGITUDINAL JOINT DETAIL (L.J.)

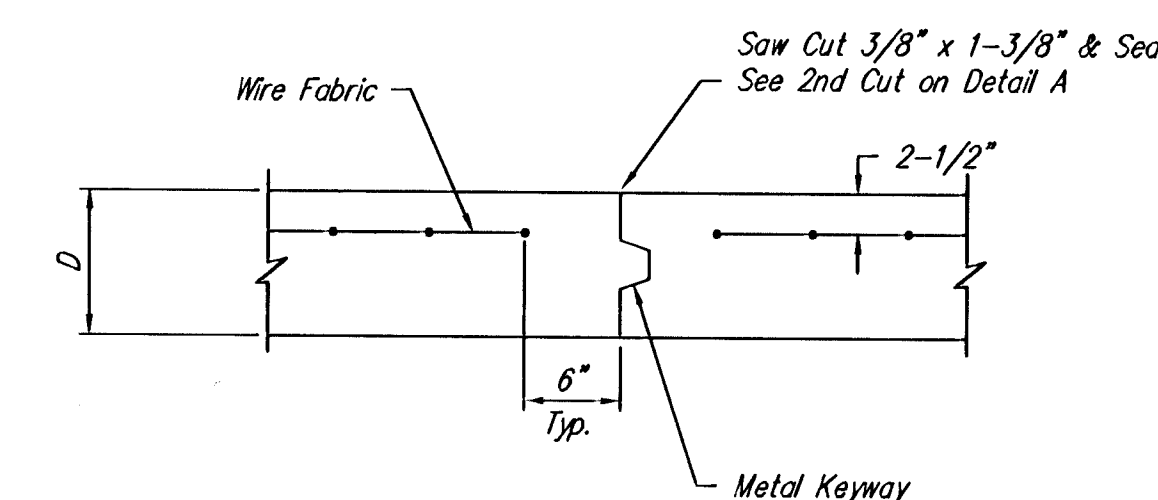

OPTIONAL CONTRACTION JOINT

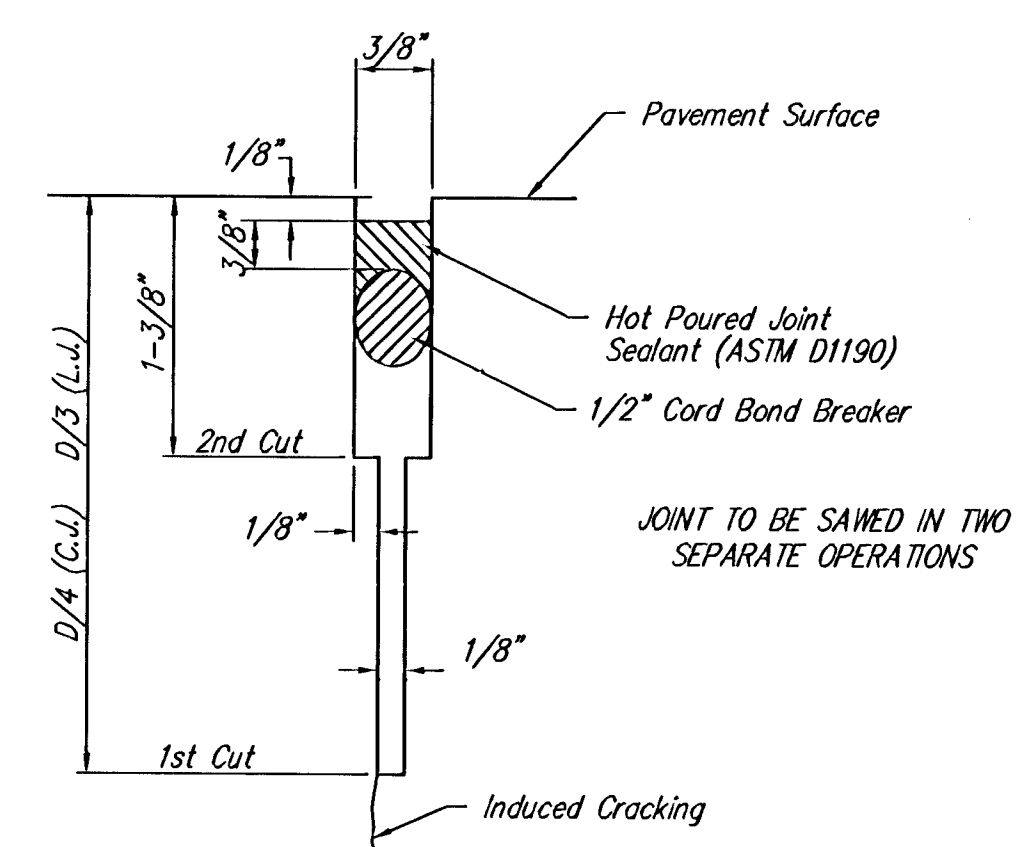

SAW JOINT DETAIL

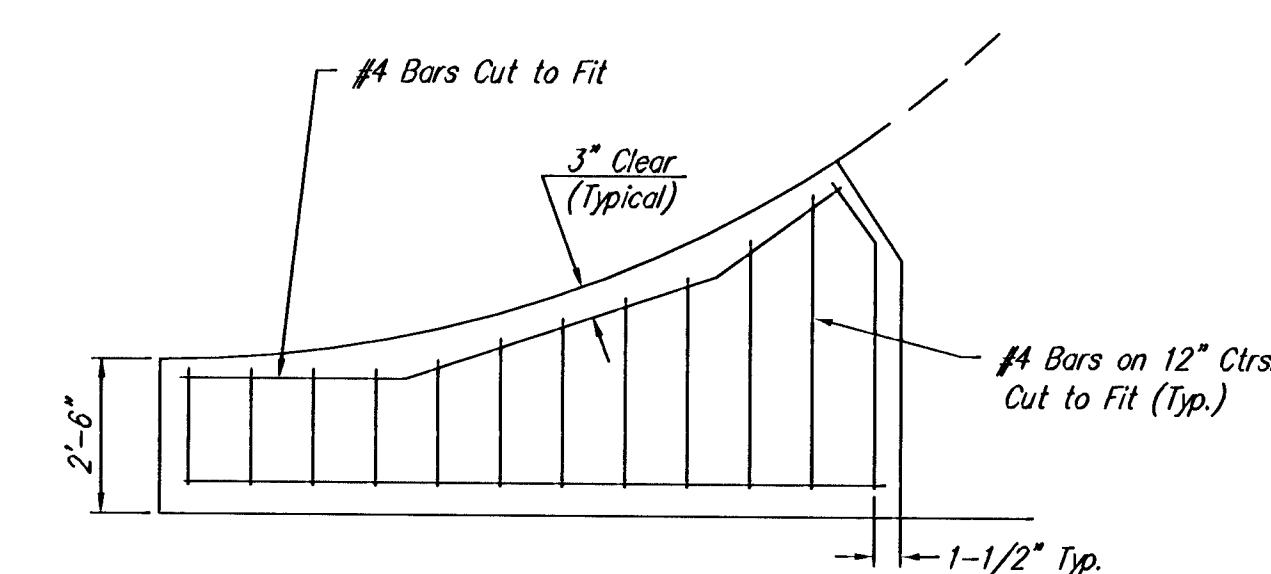

WING REINFORCING DETAIL

THE CITY OF WICHITA CITY ENGINEER'S OFFICE 455 NORTH MAIN STREET WICHITA, KANSAS 67202 (316) 268-4501 (316) 268-4114 FAX	VALLEY GUTTER DETAILS	
	NEIL D. CABLE, P.E. - CITY ENGINEER	
	PROJECT NUMBER 472-83842	OCA NUMBER 765817
	DATE OCT 2003	SHEET 5 OF 32

H:\CIVIL\96186\03131\PAV\0212IED3