

WATER VALVE BOX ELEVATIONS			
STREET	STATION	OFFSET	PROPOSED ELEVATION
RUTGERS COURT	79+37.31	22.0' Lt.	172.6
RUTGERS COURT	81+02.85	39.73' Rt.	175.0

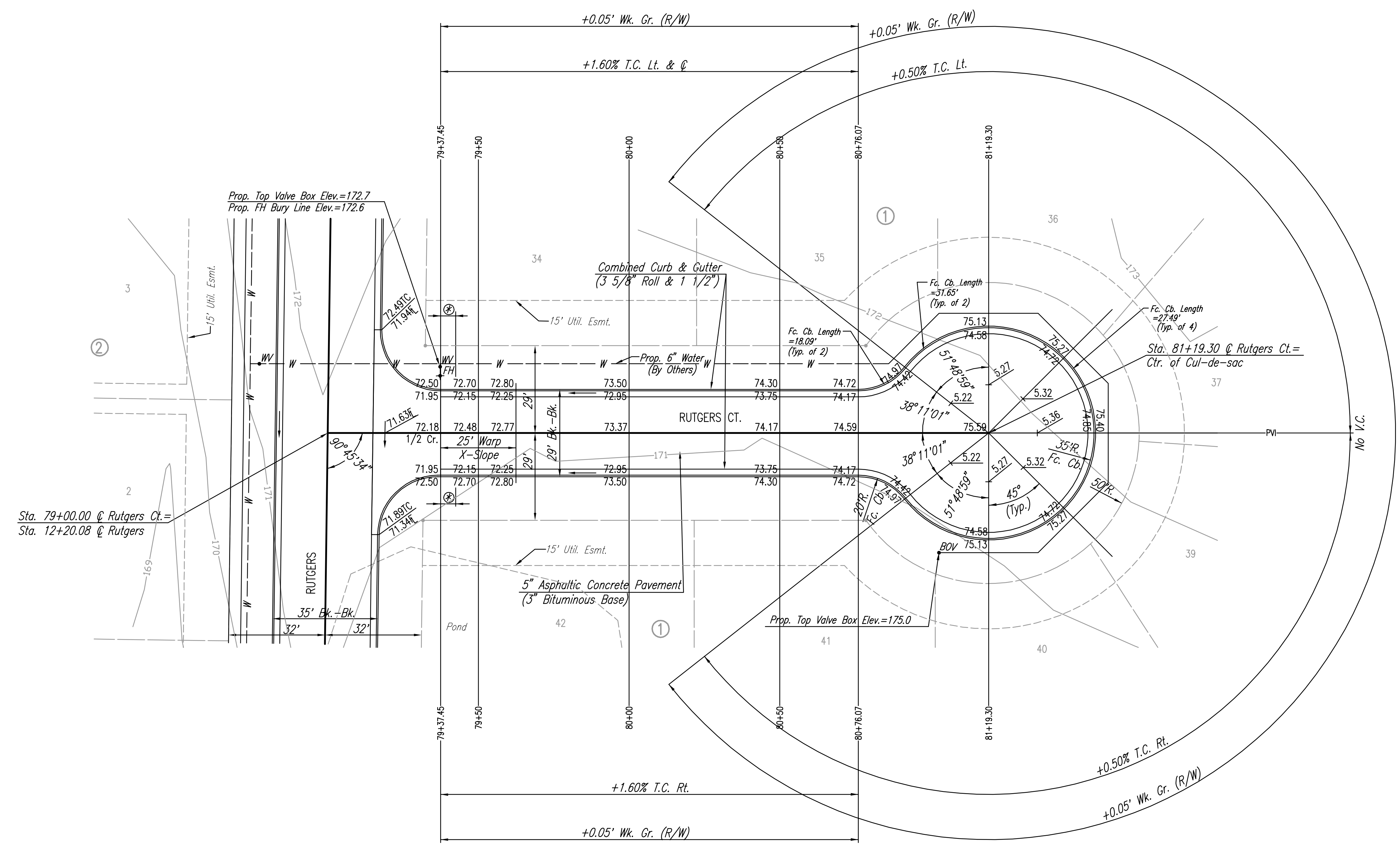

Sta. 79+00.00 @ Rutgers Ct. =
Sta. 12+20.08 @ Rutgers

Prop. Top Valve Box Elev.=172.7
Prop. FH Bury Line Elev.=172.6

Prop. Top Valve Box Elev.=175.0

Sta. 81+19.30 @ Rutgers Ct. =
Ctr. of Cul-de-sac

NOTE: THIS STREET TO BE CONSTRUCTED WITH ROLL-TYPE CURB. TOP OF CURB ELEVATIONS GIVEN ARE FOR FULL HEIGHT CURB.

⊗ 5' Transition from Combined Curb and Gutter (6 5/8" & 1 1/2") to Combined Curb and Gutter (3 5/8" Roll & 1 1/2"). To be bid and paid for as "Combined Curb and Gutter (3 5/8" Roll & 1 1/2)".

Sowed 05-02-2007 12:15:46 PM by REFJ
 Plot Scale 1:20 05-02-2007 12:15:59 PM by REFJ
 J:\SENTOU\2006\06563\2007-05-01 to City\Street\DWG\14-STR RUTGERS CT

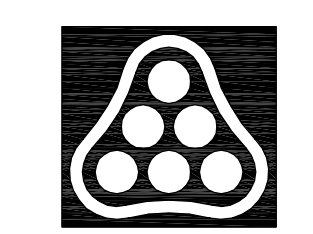

No.	Revision	By	Date

PRAIRIE POINTE-PHASE 3

RUTGERS CT.
 STA. 79+00 TO STA. 81+00
 JAMES L. ARMOUR, P.E.-CITY ENGINEER
 CITY OF WICHITA PROJECT NO. 472-84043

Professional Engineering Consultants, P.A.
 303 S. TOPEKA • WICHITA, KANSAS 67202
 316-262-2691 • FAX 316-262-3003

Designed by	BDB, BMM	Job No.	35-06563-000
Drawn by	BJS, TAT	Date	October 2006

Sheet 14 of 56