

BENCHMARKS:
 135th St. W. & 13th St. N. - City of Wichita Disc at Southwest Corner of Intersection, 30.00'± S. of C of 13th St. N. 35.00'± W. of C of 135th St. W.
 Elev. = 1355.65 MSL

"□" Cut in Top of Curb 10' South of end of Existing Pavement, East Curb adjacent to Lot 12, Block D, Copper Gate North Addition.
 Elev. = 1362.13 MSL

BM Disc in top Curb adjacent to Fire Hydrant at E. End of N. Curb Return of Kiwi & Decker, adjacent to Lot 16, Block D, Copper Gate North Addition.
 Elev. = 1361.04 MSL

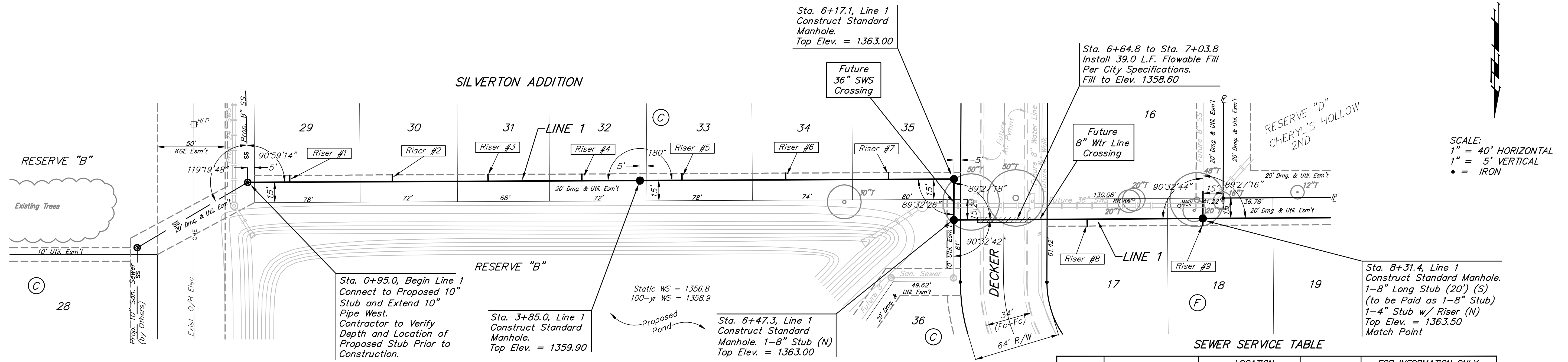

SCALE:
 1" = 40' HORIZONTAL
 1" = 5' VERTICAL
 • = IRON

SILVERTON ADDITION

Existing trees which are in direct conflict with proposed new construction shall be removed by the Contractor ONLY with approval of the Engineer. Trees not in direct conflict with proposed new construction shall remain and be protected from damage. Cost shall be included in bid item "Site Clearing & Restoration"

SEWER SERVICE TABLE

NUMBER	TYPE	LOCATION			FOR INFORMATION ONLY	
		LOT NO.	BLOCK NO.	LINE NO.	STATION/DIRECTION	APPROXIMATE LENGTH 4" PIPE
1	10" X 4" Tee Saddle	29	C	1	1+26/Lt.	9.5' VERTICAL 5' HORIZONTAL
2	10" X 4" Tee Saddle	30	C	1	2+02/Lt.	9.5' VERTICAL 5' HORIZONTAL
3	10" X 4" Tee Saddle	31	C	1	2+72/Lt.	9' VERTICAL 5' HORIZONTAL
4	10" X 4" Tee Saddle	32	C	1	3+42/Lt.	9' VERTICAL 5' HORIZONTAL
5	10" X 4" Tee Saddle	33	C	1	4+16/Lt.	9' VERTICAL 5' HORIZONTAL
6	10" X 4" Tee Saddle	34	C	1	4+92/Lt.	8.5' VERTICAL 5' HORIZONTAL
7	10" X 4" Tee Saddle	35	C	1	5+68/Lt.	9.5' VERTICAL 5' HORIZONTAL
8	10" X 4" Tee Saddle	17	F	1	7+46/Rt.	10.5' VERTICAL 5' HORIZONTAL
9	4" Stub w/Riser	18	F	1	8+31.4/Lt.	11' VERTICAL 5' HORIZONTAL

NOTE: Vertical Riser Pipe shall be extended to 2' minimum above ground water elevation and 4' maximum below proposed ground elevation.

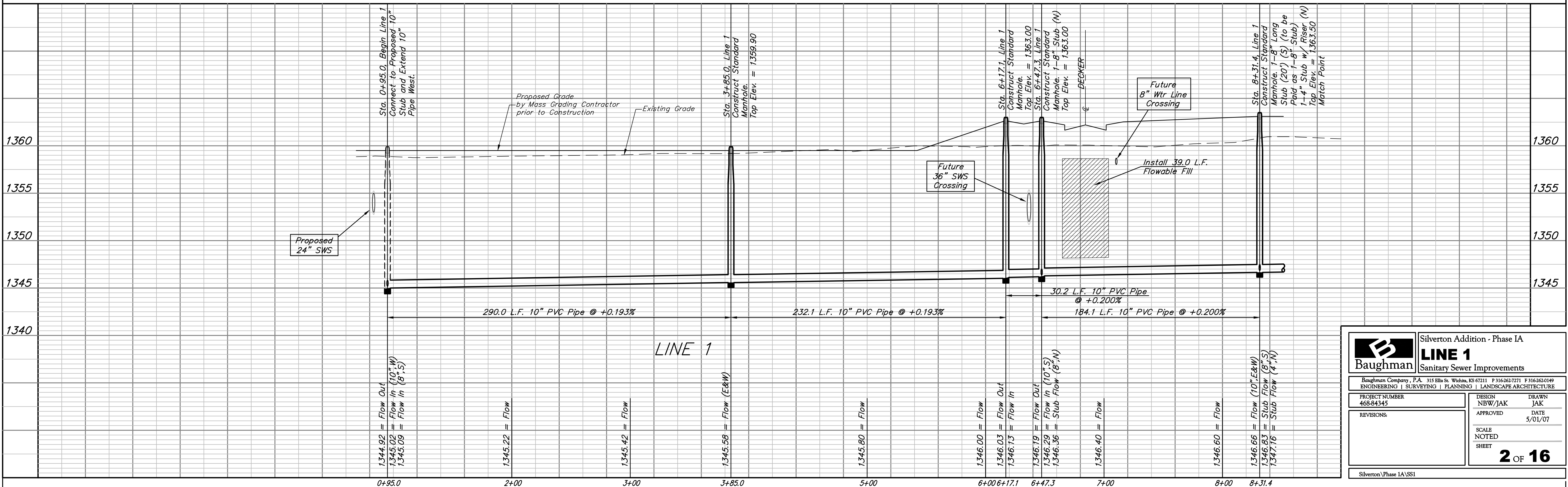

		Silvertown Addition - Phase IA	
		LINE 1 Sanitary Sewer Improvements	
<small>Baughman Company, P.A. 315 Ellis St. Wichita, KS 67211 P 316-262-7271 F 316-262-0149 ENGINEERING SURVEYING PLANNING LANDSCAPE ARCHITECTURE</small>			
PROJECT NUMBER 468-84345	DESIGN NBW/JAK	DRAWN JAK	
REVISIONS:	APPROVED	DATE 5/01/07	
SCALE NOTED		SHEET	
		2 OF 16	
<small>Silvertown Phase IA\SS1</small>			