







BENCHMARKS:

#1: "□" CUT CHISELED ON CURB,
15.2' S. OF SW COR., LOT 6,
BLOCK A, ROCKY FORD 2ND
ADDITION.
ELEV. = 1385.10 NAVD88

#2: "□" CUT CHISELED ON CURB,
8.6' N. & 11.7' W. OF SW COR.,
LOT 14, BLOCK C, ROCKY FORD
2ND ADDITION.
ELEV. = 1380.11 NAVD88

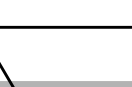
EROSION CONTROL LEGEND

-  - DROP INLET PROTECTION
-  - CURB INLET PROTECTION
-  - DITCH CHECKS
-  - SILT FENCING
-  - CUT-OFF TRENCH
-  - TEMPORARY DITCH

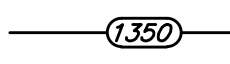
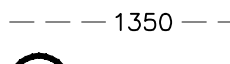
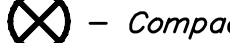
-  Area to be graded
-  Proposed Grade
-  Existing Grade
-  Compaction Testing Location

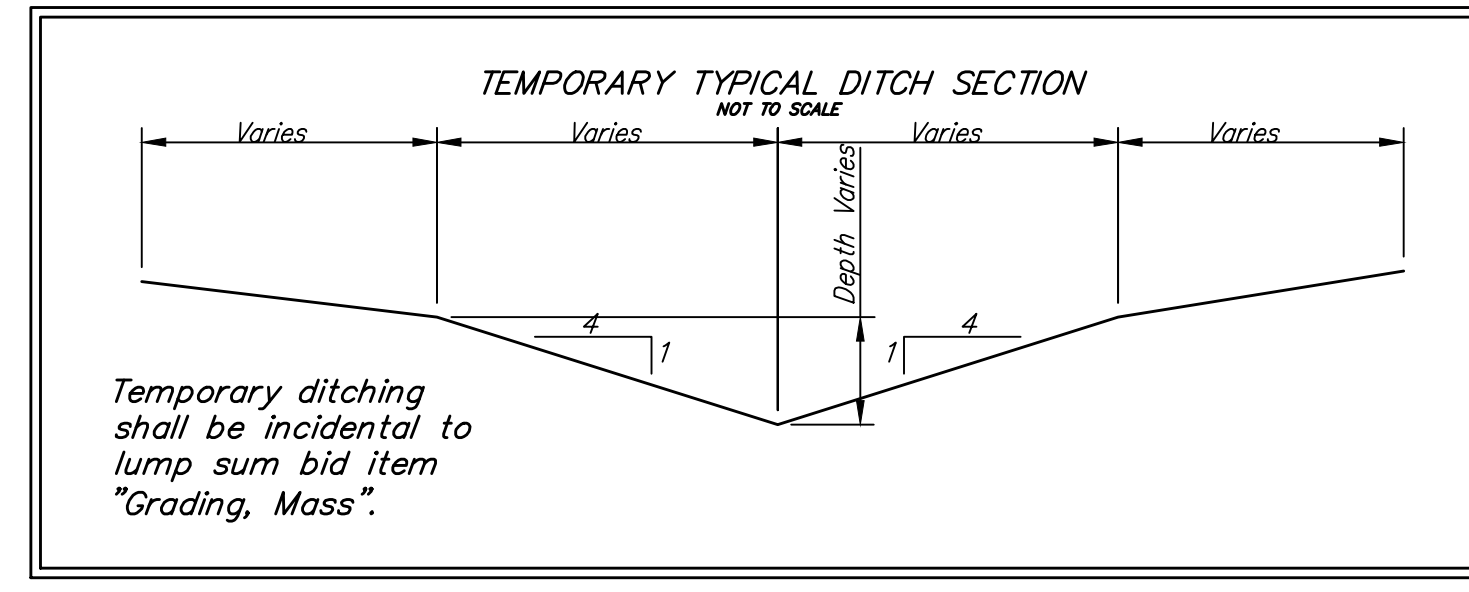
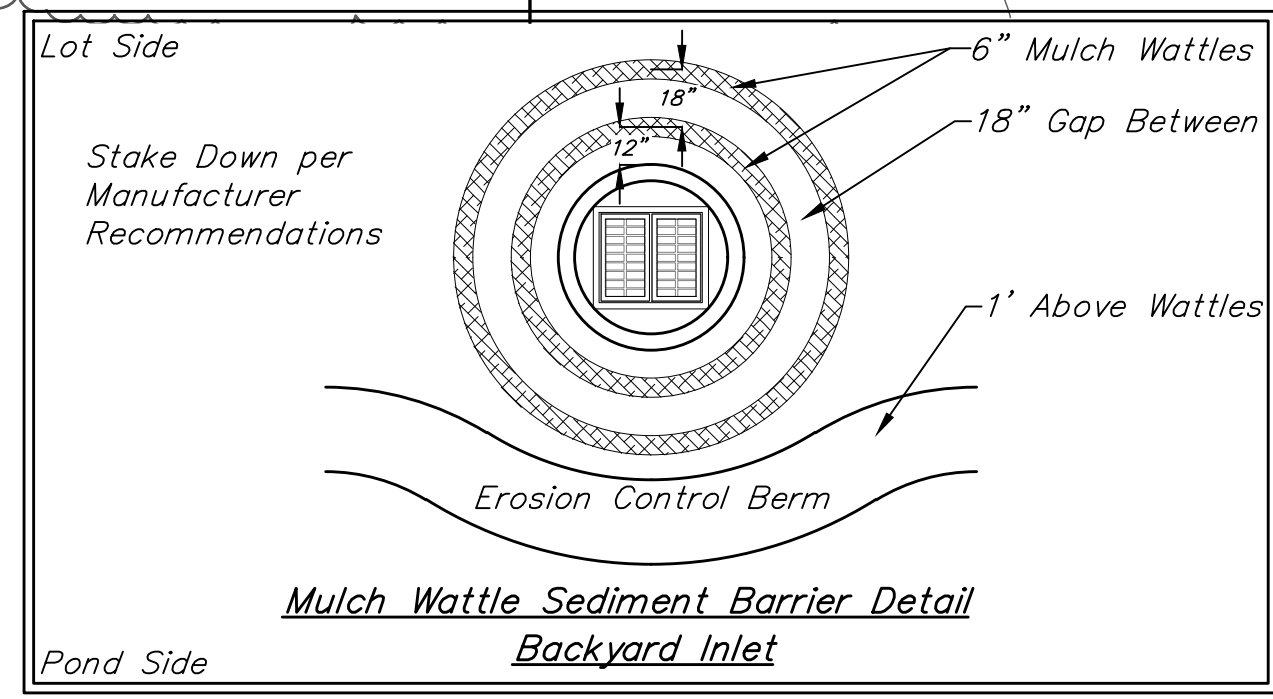
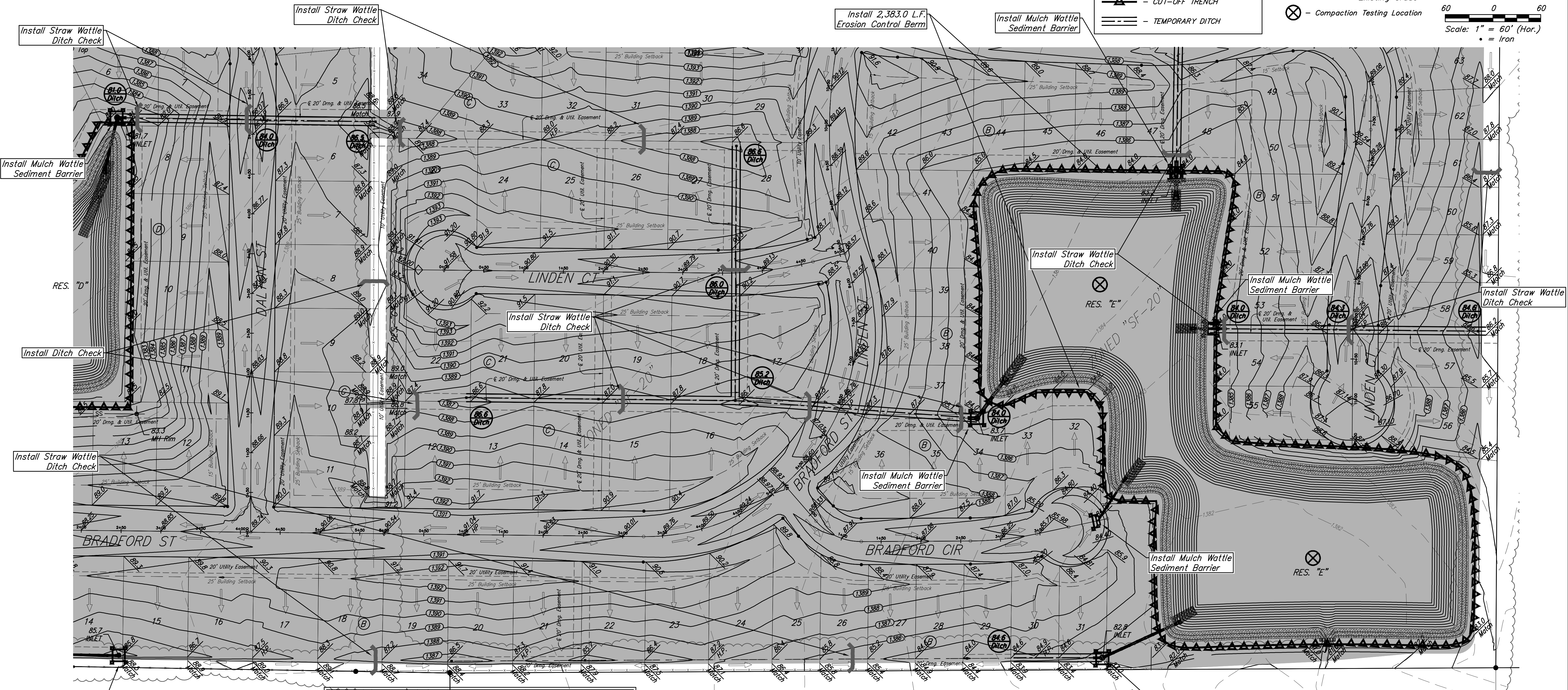
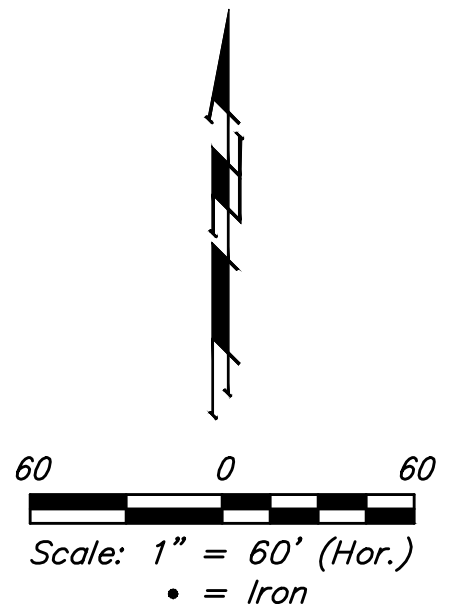

Contractor to ensure temporary ditching will drain to proposed inlets and will not bypass inlets, causing erosion of pond sideslopes. Add berming on the pond side of the inlets to direct drainage to the inlet grates. Cost to be incidental to "Grading, Mass".

		R.F. Addition MASS GRADING Stormwater Drain Improvements	
		Baughman Company, P.A. 315 Ellis St. Wichita, KS 67211 P 316-262-7271 F 316-262-0149 ENGINEERING SURVEYING PLANNING LANDSCAPE ARCHITECTURE	
PROJECT NUMBER 468-2019-085421		DESIGN AEG	
REVISIONS:		DRAWN HW	
APPROVED		DATE 04/13/20	
SCALE Noted		SHEET 12 OF 28	