

File: L:\2019\19T41016 - Emerald Bay 4th PH 2\Drawings\C3D\Storm Sewer\SWS LINE 2.dwg Last Save: 5/5/2020 10:16 AM Last saved by: Dstandrich  
 Last plotted by: Dstandrich, Dairy R Plot Style: --- Plot Scale: 1:2.585 Plot Date: 5/5/2020 11:01 AM Plotted used: None

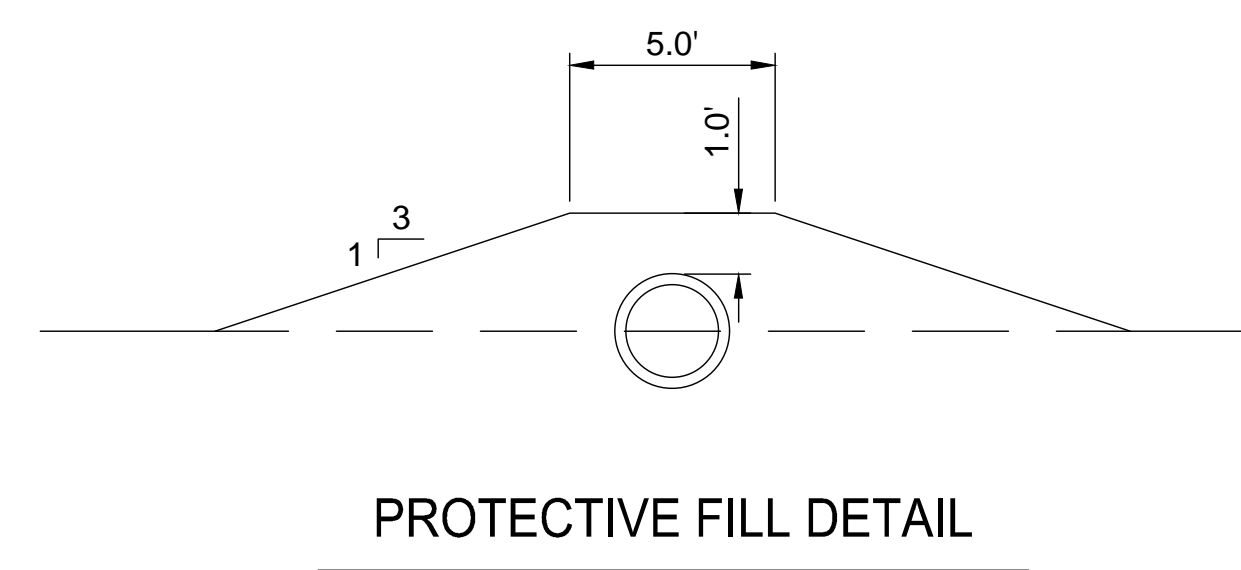
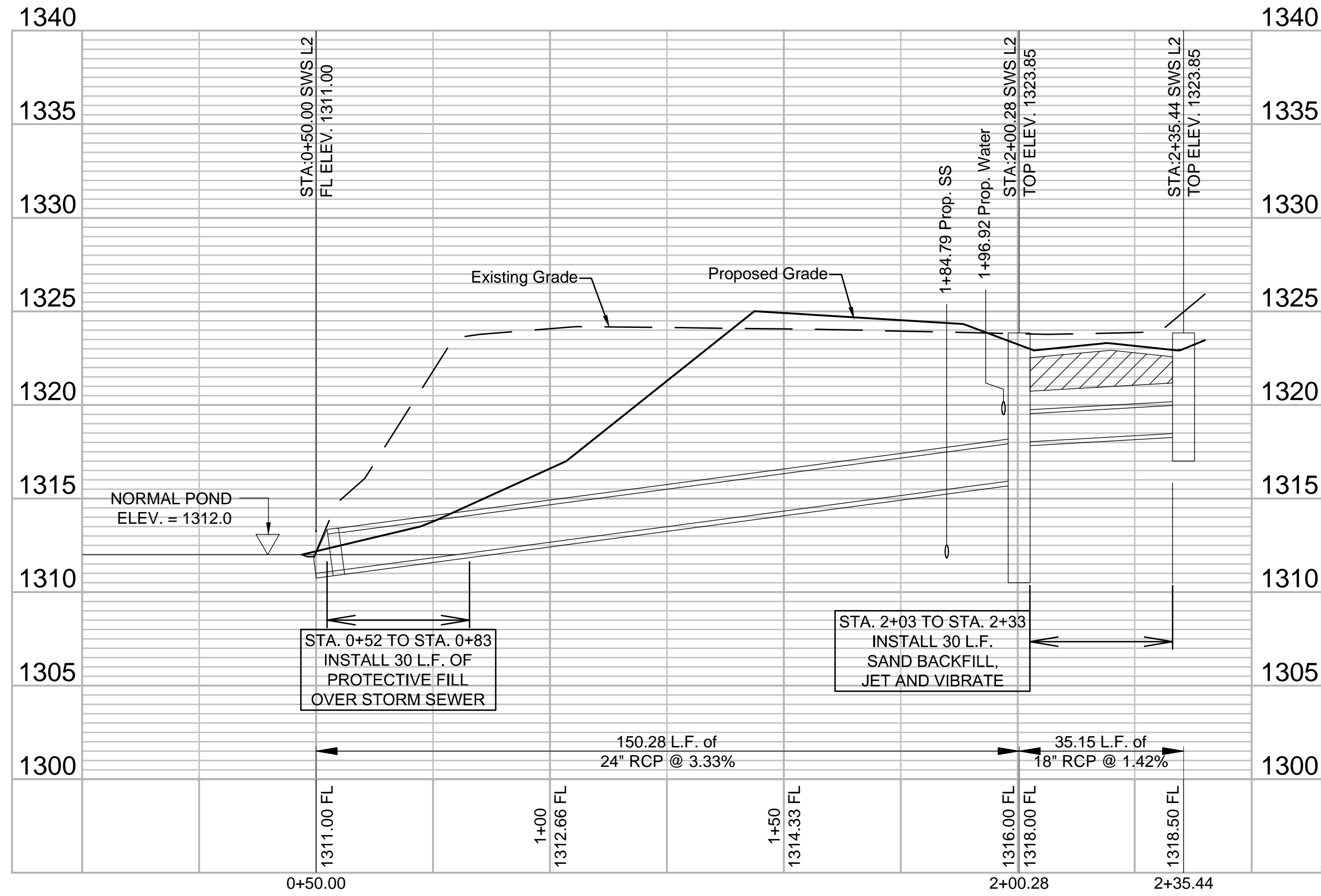
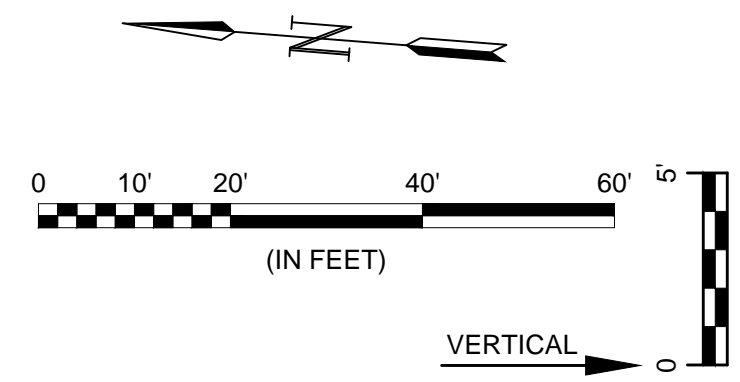
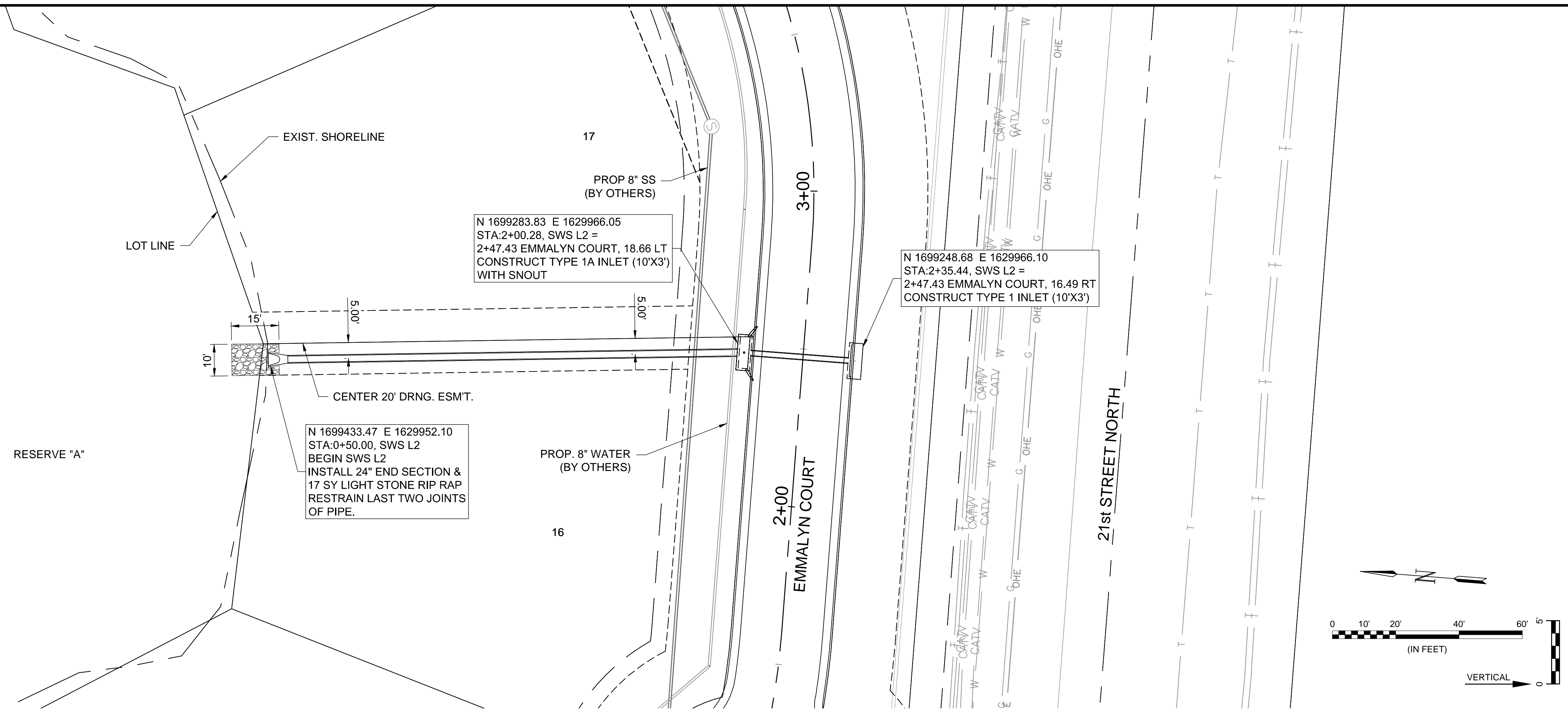

**GARVER**  
 © 2020 GARVER, LLC  
 THIS DOCUMENT, ALONG WITH THE IDEAS AND DESIGNS CONVEYED HEREIN, SHALL BE CONSIDERED INSTRUMENTS OF PROFESSIONAL SERVICE AND ARE PROPERTY OF GARVER, LLC. ANY USE, REPRODUCTION, OR DISTRIBUTION OF THIS DOCUMENT, ALONG WITH THE IDEAS AND DESIGN CONTAINED HEREIN, IS PROHIBITED UNLESS AUTHORIZED IN WRITING BY GARVER, LLC OR EXPLICITLY ALLOWED IN THE GOVERNING PROFESSIONAL SERVICES AGREEMENT FOR THIS WORK.  
 8535 E. 21st St. N.  
 Suite 130  
 Wichita, KS 67206  
 (316) 264-8008

REV.	DATE	DESCRIPTION	BY

**CITY OF WICHITA**  
 WICHITA, KANSAS  
 EMERALD BAY 4th ADD.  
 PHASE 2 - SWS

**SWS LINE 2**  
 JOB NO.: 19T41016  
 DATE: MAY 2020  
 DESIGNED BY: EJJ  
 DRAWN BY: DRS  
 BAR IS ONE INCH ON ORIGINAL DRAWING  
 IF NOT ONE INCH ON THIS SHEET, ADJUST SCALES ACCORDINGLY.  
 DRAWING NUMBER  
 SHEET NUMBER **9** OF **30**