

BENCHMARKS:
 135th St. W. & Pawnee
 City of Wichita Benchmark Disc,
 Northeast Corner of Intersection
 On SW Corner of Concrete Base
 of High Line Pole.
 Elev. = 1359.65 NGVD29

City of Wichita Benchmark Disc,
 0.4 Mi. South of Kellogg On
 135th St. W., West Side of
 Concrete Base for High Line
 Pole, West of K.G.&E.
 Substation, 135± South of
 Railroad Tracks On East Side of
 135th St. W.
 Elev. = 1367.77 NGVD29

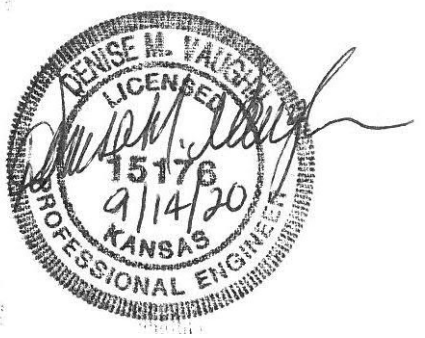
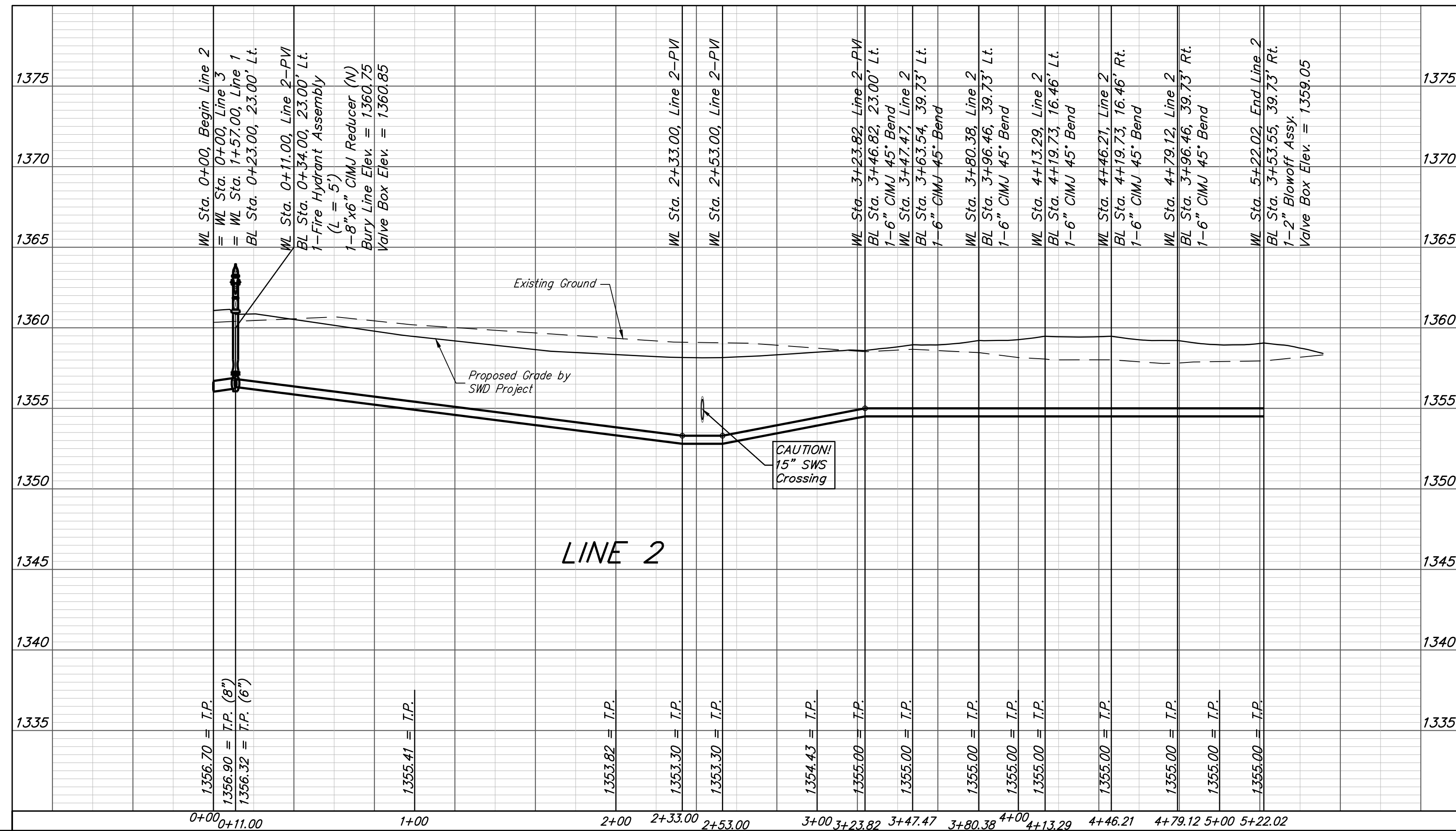
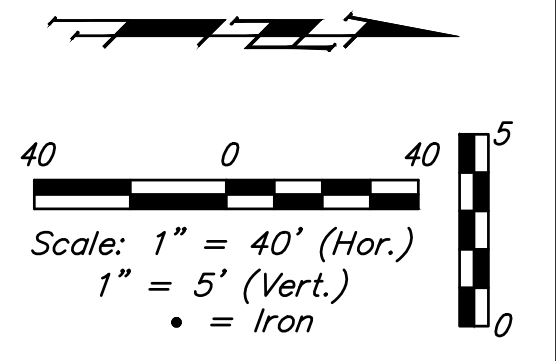
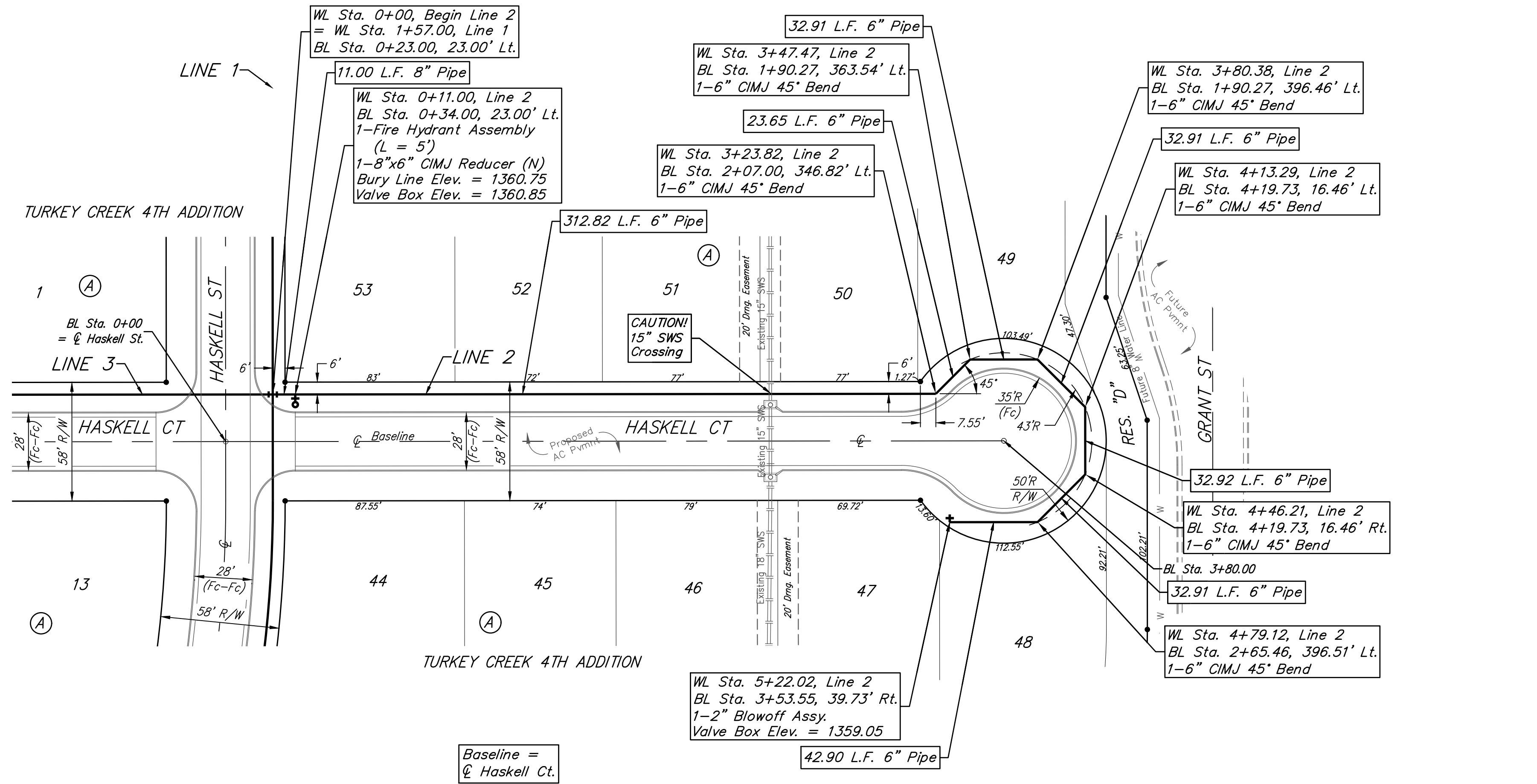

		Turkey Creek 4th Addition - Phase 1A	
		LINE 2	
Baughman Company, P.A. 315 Ellis St. Wichita, KS 67211 P 316-262-7271 F 316-262-0149		ENGINEERING SURVEYING PLANNING LANDSCAPE ARCHITECTURE	
PROJECT NUMBER 448-2020-016821	DESIGN DMV	DRAWN JAK	DATE 9/10/2020
REVISIONS:	SCALE Noted		
	SHEET		
		5 OF 15	