

BENCHMARKS:
 135th St. W. & Pawnee
 City of Wichita Benchmark Disc,
 Northeast Corner of Intersection
 On SW Corner of Concrete Base
 of High Line Pole.
 Elev. = 1359.65 NGVD29

City of Wichita Benchmark Disc,
 0.4 Mi. South of Kellogg On
 135th St. W., West Side of
 Concrete Base for High Line
 Pole, West of K.G.&E.
 Substation, 135± South of
 Railroad Tracks On East Side of
 135th St. W.
 Elev. = 1367.77 NGVD29

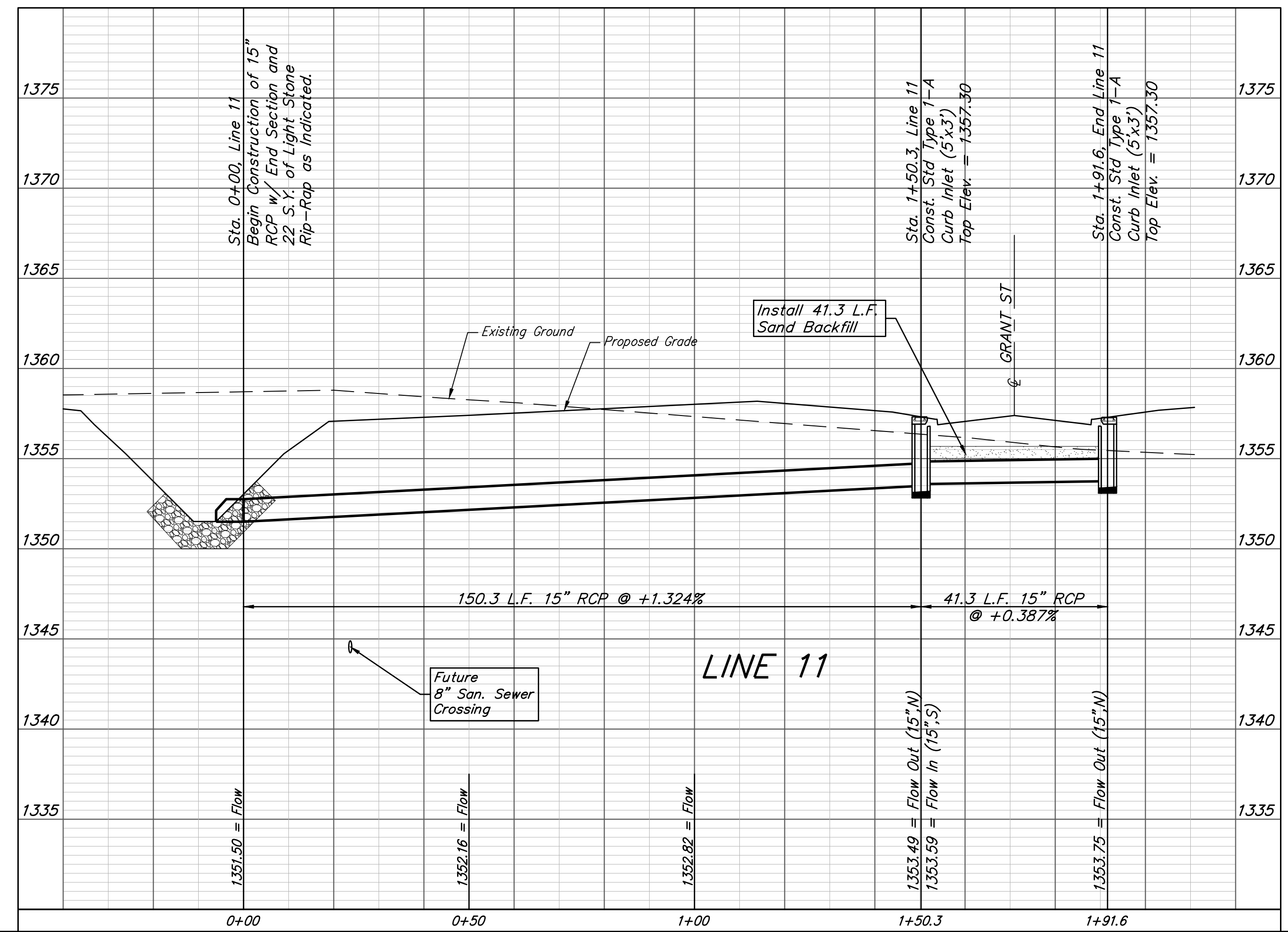
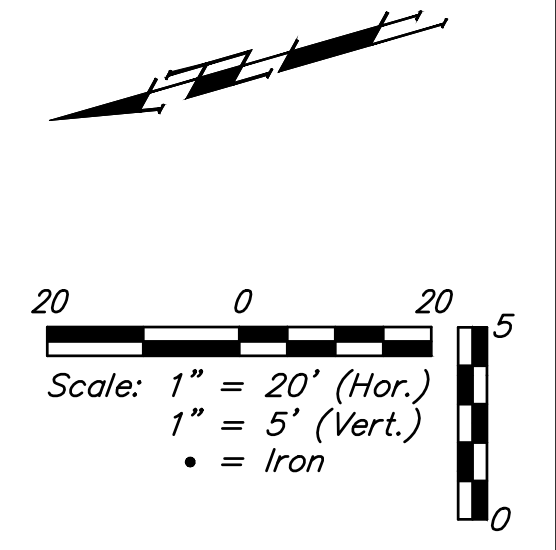
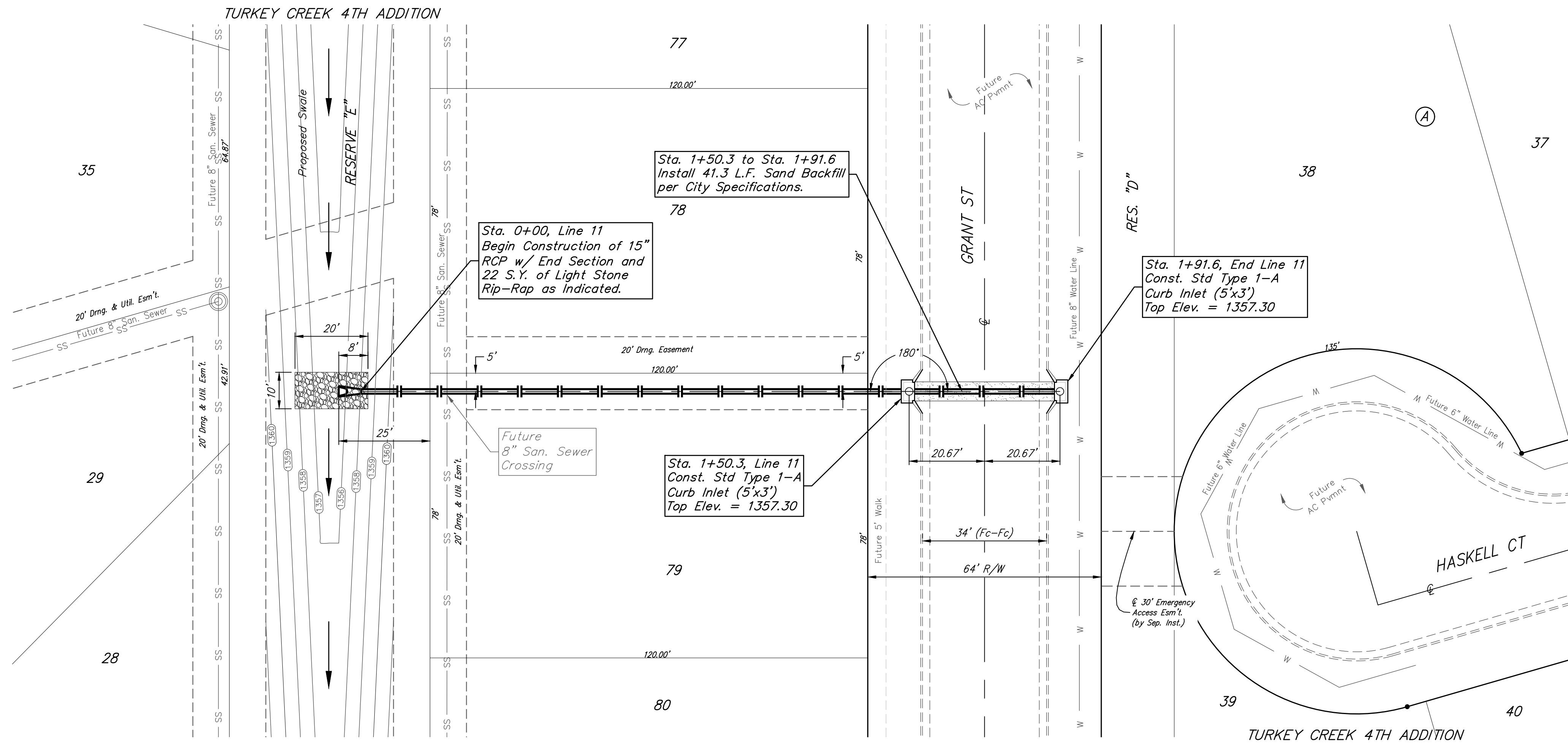

		Turkey Creek 4th Addition	
		LINE 11	
Storm Water Drain #467		Baughman Company, P.A. 315 Ellis St. Wichita, KS 67211 P 316-262-7271 F 316-262-0149 ENGINEERING SURVEYING PLANNING LANDSCAPE ARCHITECTURE	
PROJECT NUMBER 468-2020-085444	DESIGN DMV	DRAWN JAK	DATE 9/20/2020
REVISIONS:	APPROVED	SCALE Noted	SHEET
		35 OF 65	