

BENCHMARKS:
 BM #1: "□" Cut on top of curb adjacent to the SE Cor. Lot 28, Block A, Northgate Addition. Elev. = 1339.82 NAVD88

BM #2: "□" Cut on top of curb, adjacent to the SW Cor. Lot 17, Block D, Northgate Addition. Elev. = 1338.86 NAVD88

BM #3: "□" Cut on curb inlet, adjacent to the SW Cor. Lot 1, Block C, Northgate 4th Addition. Elev. = 1336.32 NAVD88

Street & Station	Location Description	Elevation
Edwards Ct. 4+12.75, 14.50' Rt.	Adjacent to Fire Hydrant near common front lot corner of Lots 21 and 22, Block A, Northgate 4th Addition.	

WATER VALVE LOCATION TABLE

VALVE NUMBER	STREET	BASELINE STATION	OFFSET DISTANCE	OFFSET DIRECTION
V1	Edwards St.	1+80.34	25'	Rt.
V2	Edwards Ct.	3+41.26	21'	Rt.
V3	Edwards Ct.	4+12.75	22'	Rt.

Paving contractor will be responsible to operate all water valves on the project, in the presence of the inspector, to ensure accessibility to the valves, and that all valves (except blowoffs) are left in the "ON" position when the project is completed.

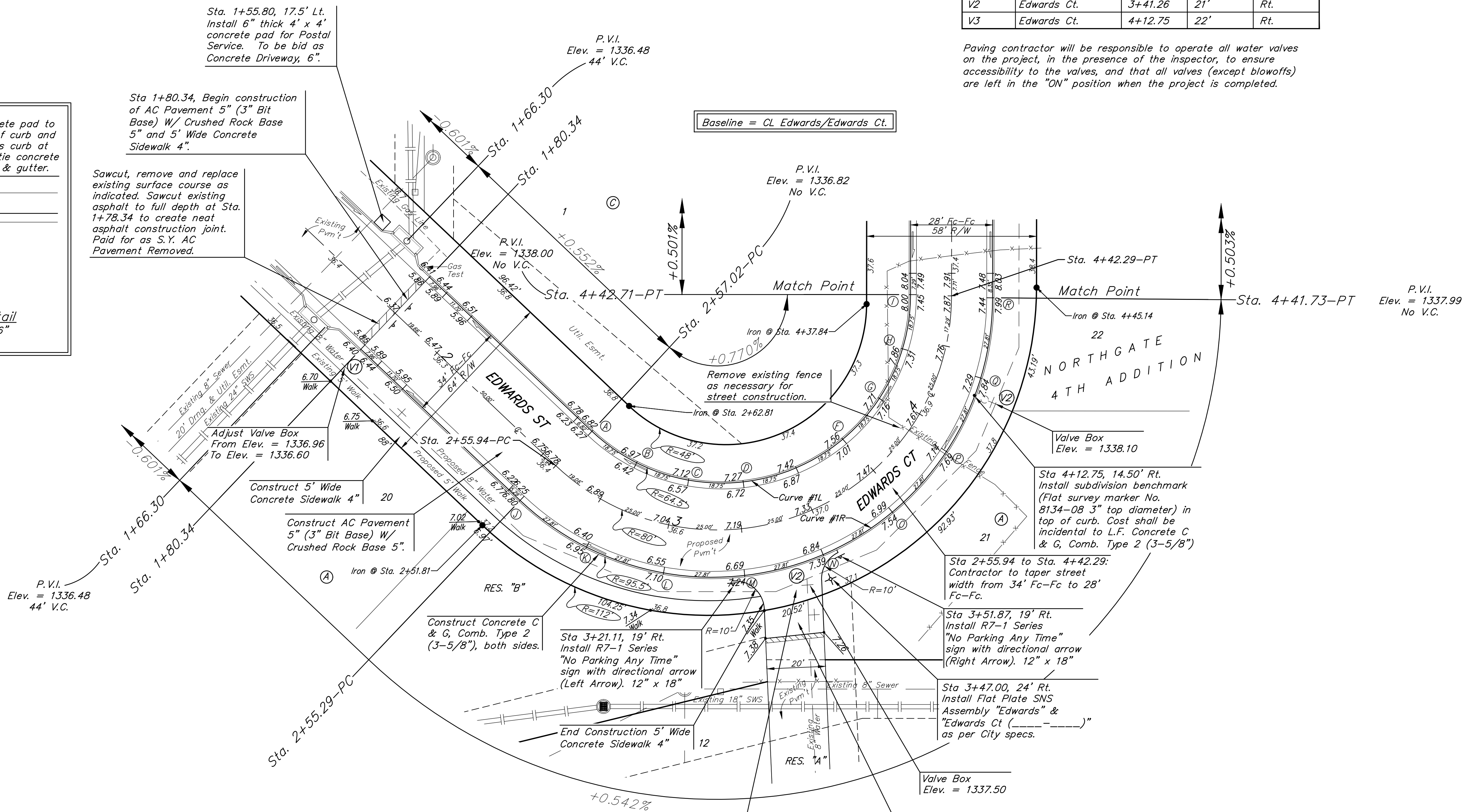
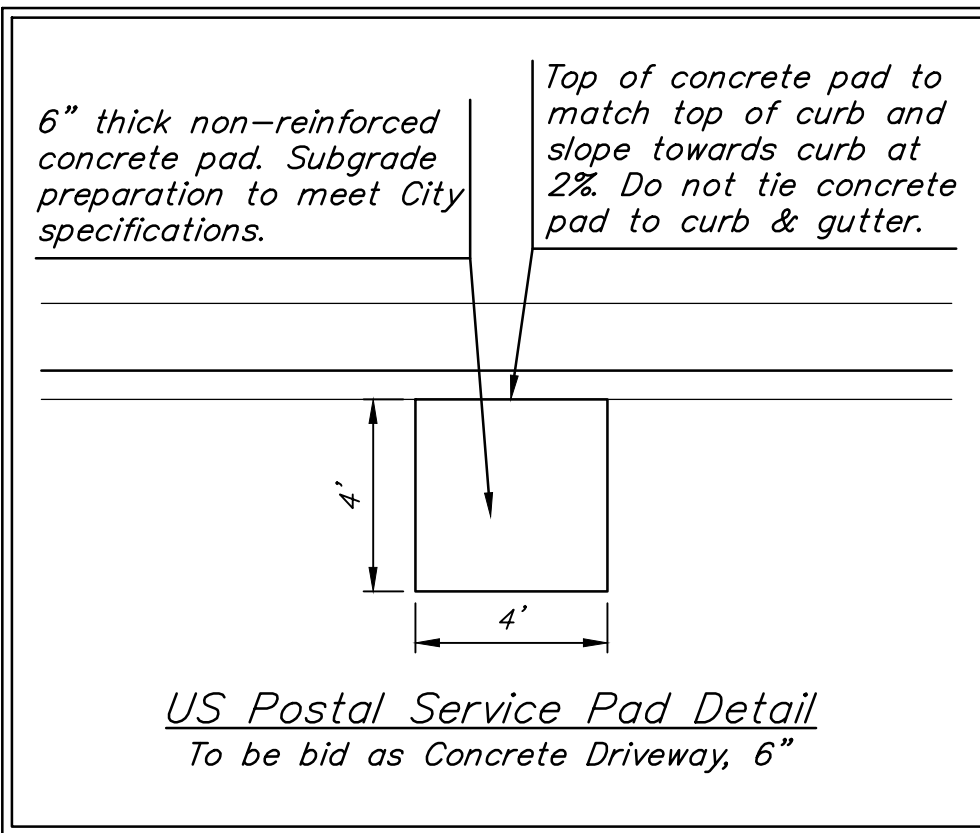
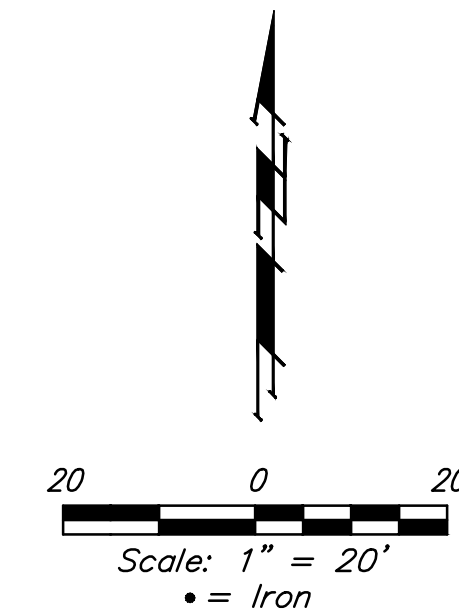

Curve #1L				
Curve Data Based on Face of Curb				
Rad. = 64.5' Delta = 133°27'56" Tangent = 150.00'				
Arc = 150.00' L.C. = 118.51' Def./Ft. = 26.69311 Min.				
Chord Lengths	Arc	8' Left	Defl.	Total Defl.
A	-	-	0°00'00"	0°00'00"
B	18.75'	16.39'	8°20'30"	8°20'30"
C	18.75'	16.39'	8°20'30"	16°41'00"
D	18.75'	16.39'	8°20'29"	25°01'29"
E	18.75'	16.39'	8°20'30"	33°21'59"
F	18.75'	16.39'	8°20'30"	41°42'29"
G	18.75'	16.39'	8°20'30"	50°02'59"
H	18.75'	16.39'	8°20'29"	58°23'28"
I	18.75'	16.39'	8°20'30"	66°43'58"

Curve #1R				
Curve Data Based on Face of Curb				
Rad. = 95.5' Delta = 133°27'56" Tangent = 222.10'				
Arc = 222.48' L.C. = 175.47' Def./Ft. = 17.99697 Min.				
Chord Lengths	Arc	8' Right	Defl.	Total Defl.
J	-	-	0°00'00"	0°00'00"
K	27.81'	30.03'	8°20'30"	8°20'30"
L	27.81'	30.03'	8°20'30"	16°41'00"
M	27.81'	30.03'	8°20'29"	25°01'29"
N	27.81'	30.03'	8°20'30"	33°21'59"
O	27.81'	30.03'	8°20'30"	41°42'29"
P	27.81'	30.03'	8°20'30"	50°02'59"
Q	27.81'	30.03'	8°20'29"	58°23'28"
R	27.81'	30.03'	8°20'30"	66°43'58"

NOTE: ROLL TYPE CURB & GUTTER (TYPE 2) TO BE CONSTRUCTED ON THE PAVEMENT SHOWN ON THIS SHEET. TOP OF CURB ELEVATIONS ARE GIVEN FOR FULL HEIGHT CURB (TYPE 4).

BAUGHMAN COMPANY
 315 Ellis St.
 Wichita, KS 67211
 316-262-7271
 BaughmanCo.com

NORTHGATE ADDITION
 Phase 4B

**EDWARDS ST./
 EDWARDS CT.**

STREET
 IMPROVEMENTS

PROJECT NUMBER:

DESIGN: AEG DRAWN: TMS
 DATE: August 9, 2021

SHEET **2** OF **18**

File: E:\Projects\Northgate\Engineering\Phase 4B\STR\STR.dwg