

BENCHMARK:
Top of 1" Iron 12" Deep, E1/4 Cor.,
Sec. 27, Twp. 27-S, R-2-W.
Elev. = 209.13 (City Datum)

REECE FARMS ESTATES

SCALE:
1" = 40' HORIZONTAL
1" = 5' VERTICAL
• = IRON

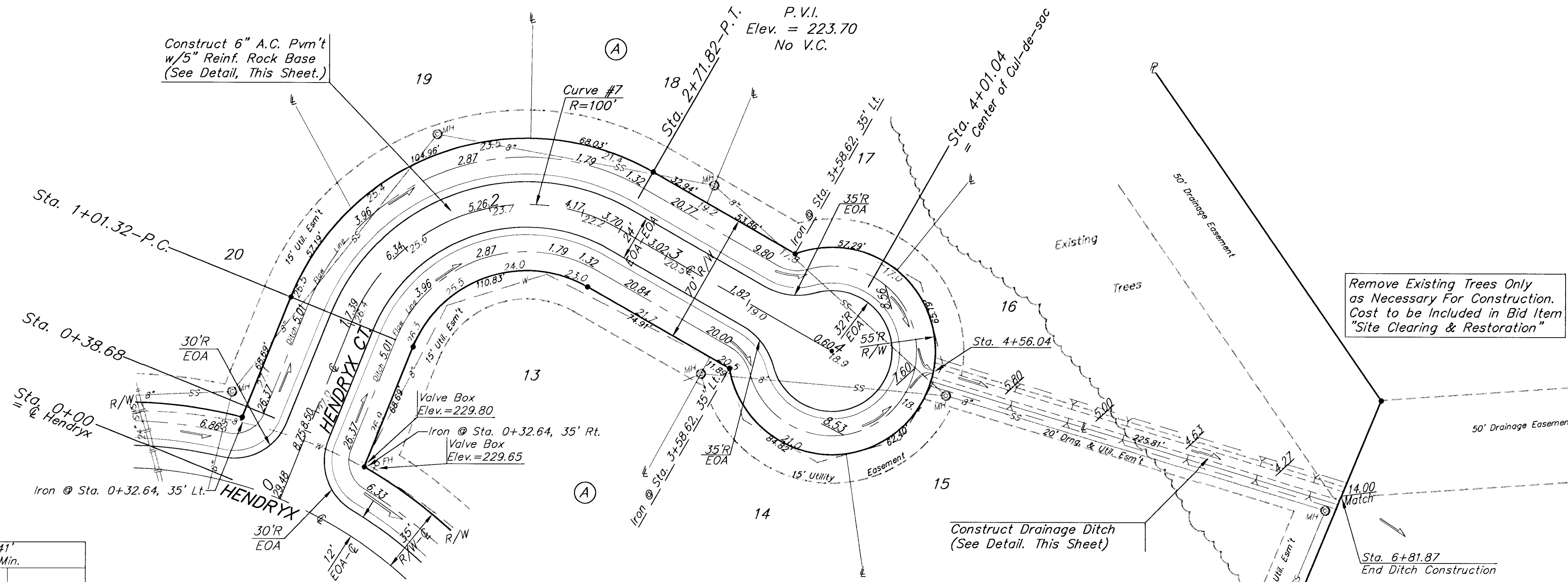

Curve #7
Curve Data Based on Centerline
Rad. = 100' Delta = 97° 41' 22" Tangent = 114.41'
Arc = 170.50' L.C. = 150.59' Def/Ft. = 17.18876 Min.

Station	Arc	CHORD LENGTHS		Def.	T. Def.
		12' Lt.	12' Rt.		
1+01.32	-	-	-	0°00'00"	0°00'00"
1+25.00	23.68'	20.79'	26.46'	6°47'02"	6°47'02"
1+50.00	25.00'	21.94'	27.93'	7°09'43"	13°56'45"
1+75.00	25.00'	21.94'	27.93'	7°09'43"	21°06'28"
2+00.00	25.00'	21.94'	27.93'	7°09'43"	28°16'11"
2+25.00	25.00'	21.94'	27.93'	7°09'43"	35°25'54"
2+50.00	25.00'	21.94'	27.93'	7°09'43"	42°35'37"
2+71.82	21.82'	19.16'	24.39'	6°15'04"	48°50'41"

REECE FARMS ESTATES

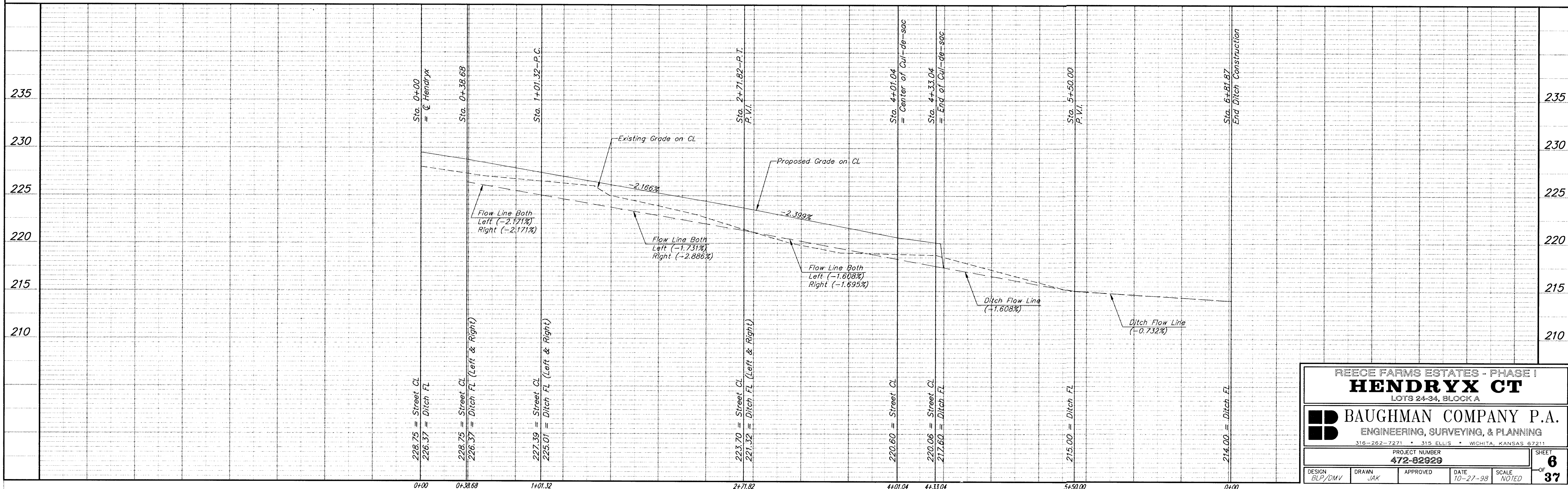
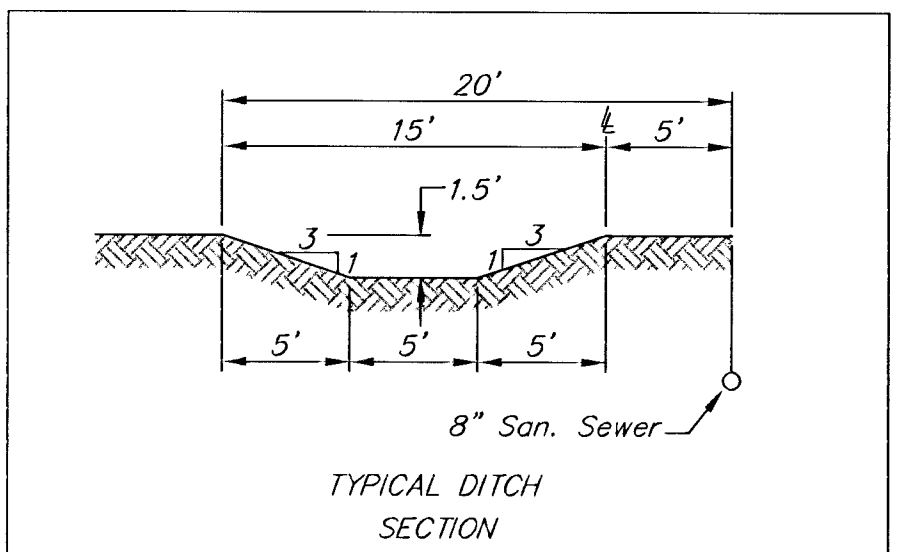

REECE FARMS ESTATES - PHASE I
HENDRYX CT
LOTS 24-34, BLOCK A

BAUGHMAN COMPANY P.A.
ENGINEERING, SURVEYING, & PLANNING
316-282-7271 • 315 ELLIS • WICHITA, KANSAS 67211

PROJECT NUMBER
472-82929

DESIGN: BLP/DMV DRAWN: JAK APPROVED: DATE: 10-21-98 SCALE: NOTED SHEET: **6** OF **37**