

EXPANSION JOINT

NOTE: Extra Thickness to be Subsidiary to Price of Square Yards Pavement

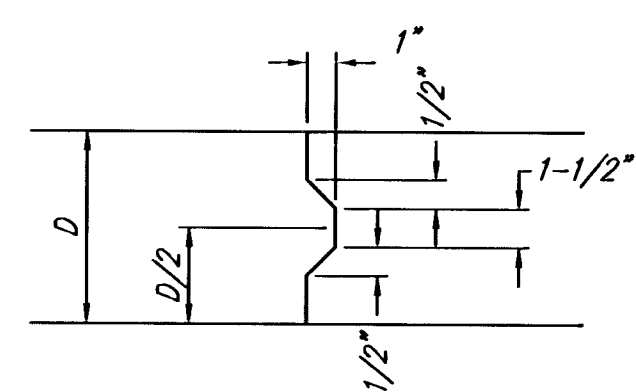

KEYWAY DETAIL

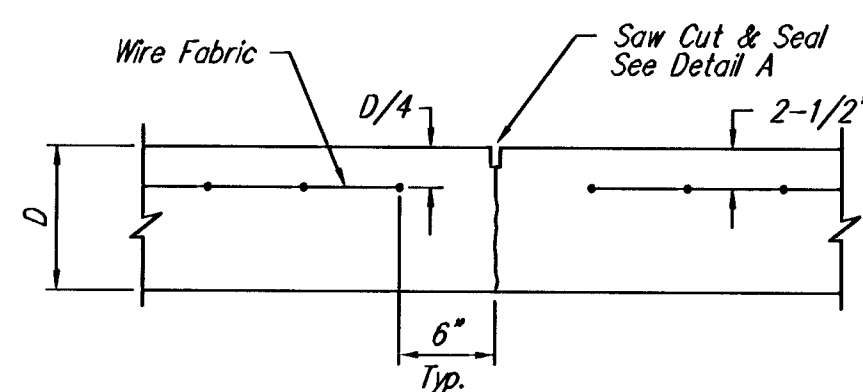

CONTRACTION JOINT DETAIL (C.J.)

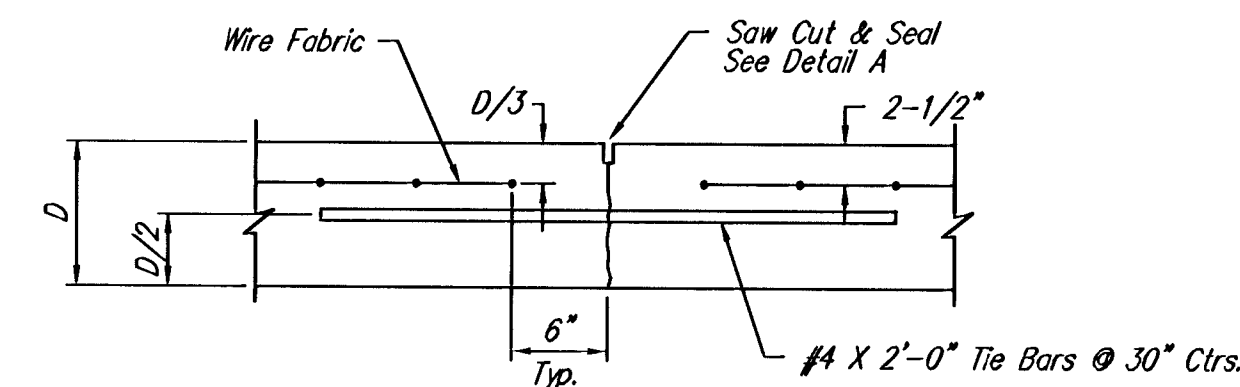

LONGITUDINAL JOINT DETAIL (L.J.)

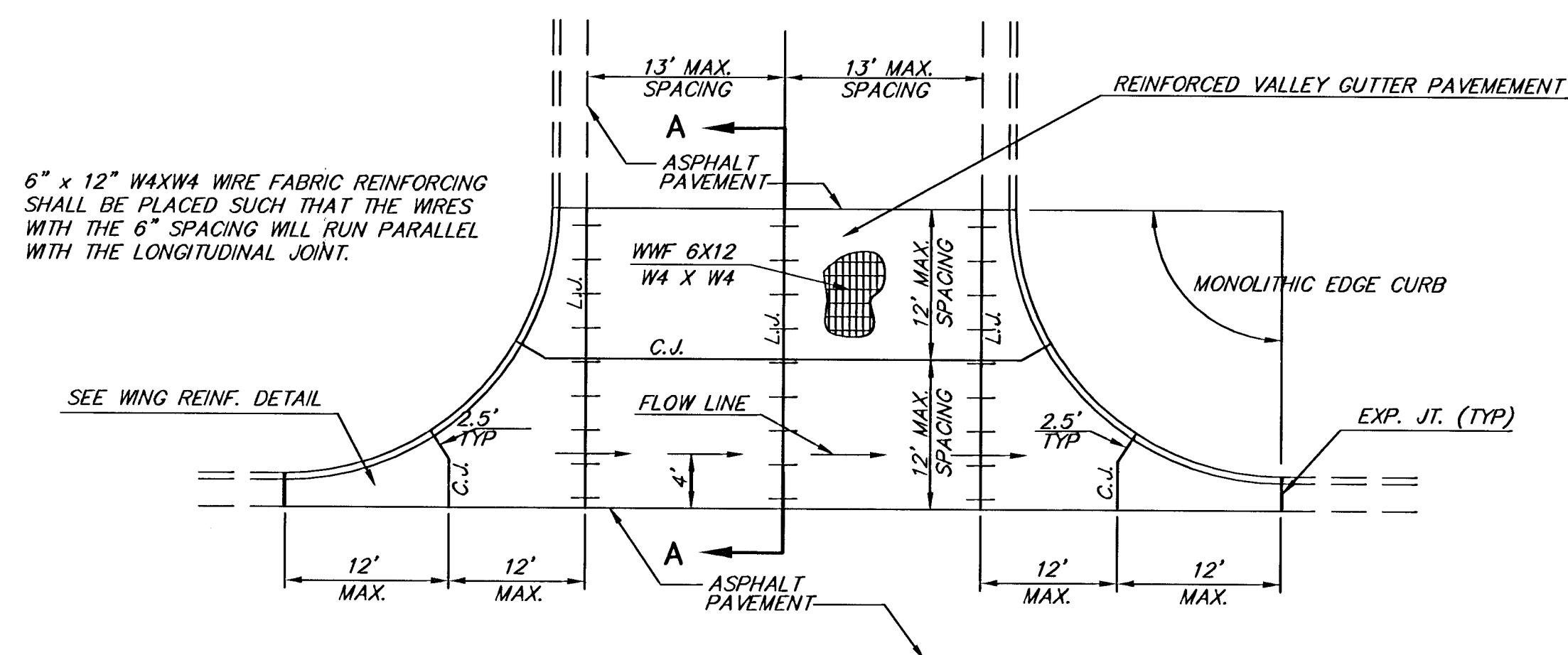

PLAN

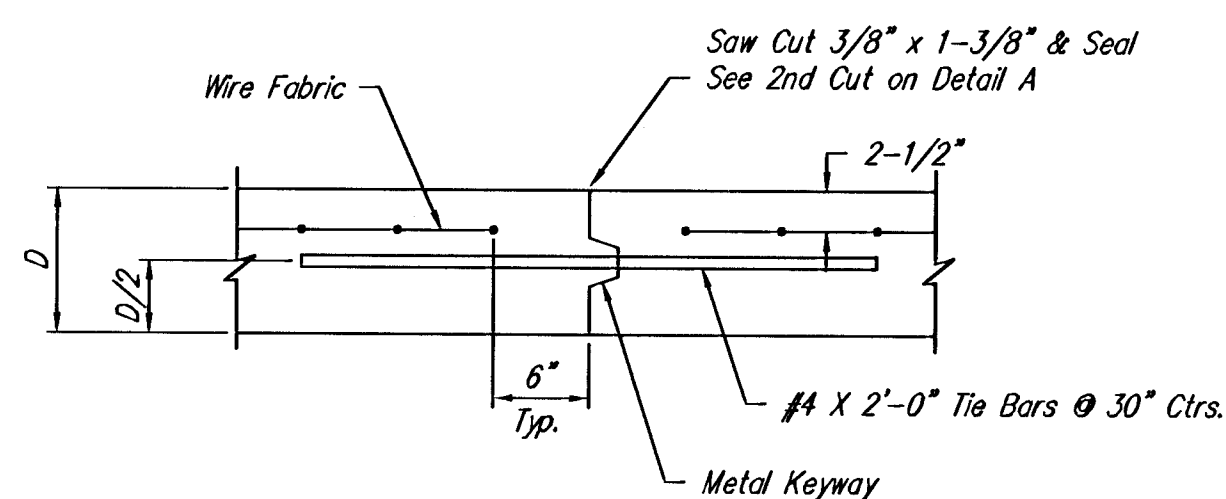

OPTIONAL LONGITUDINAL JOINT DETAIL (L.J.)

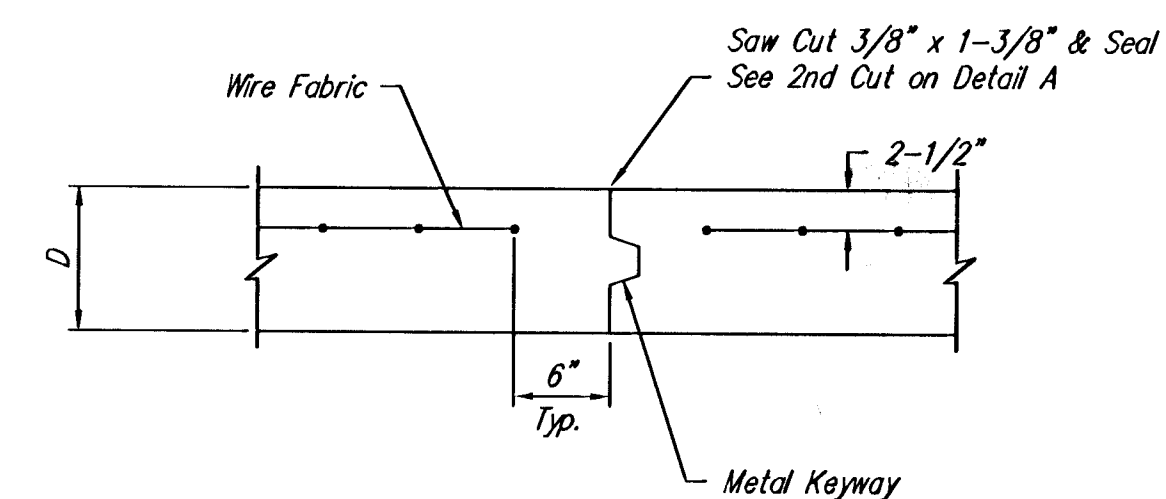

OPTIONAL CONTRACTION JOINT

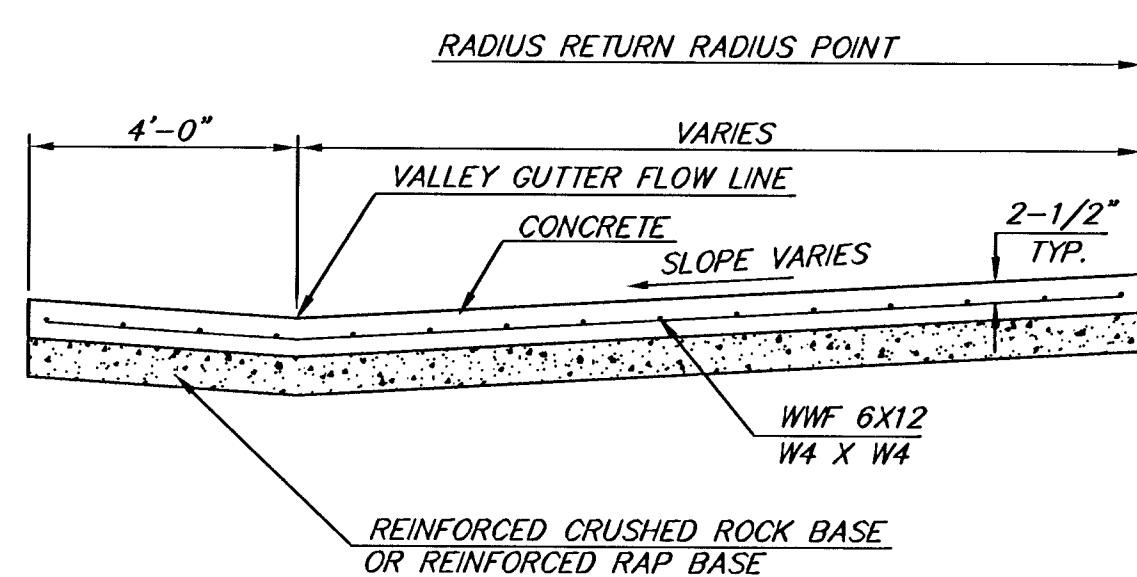

SECTION A-A

REINFORCED VALLEY GUTTER DETAIL

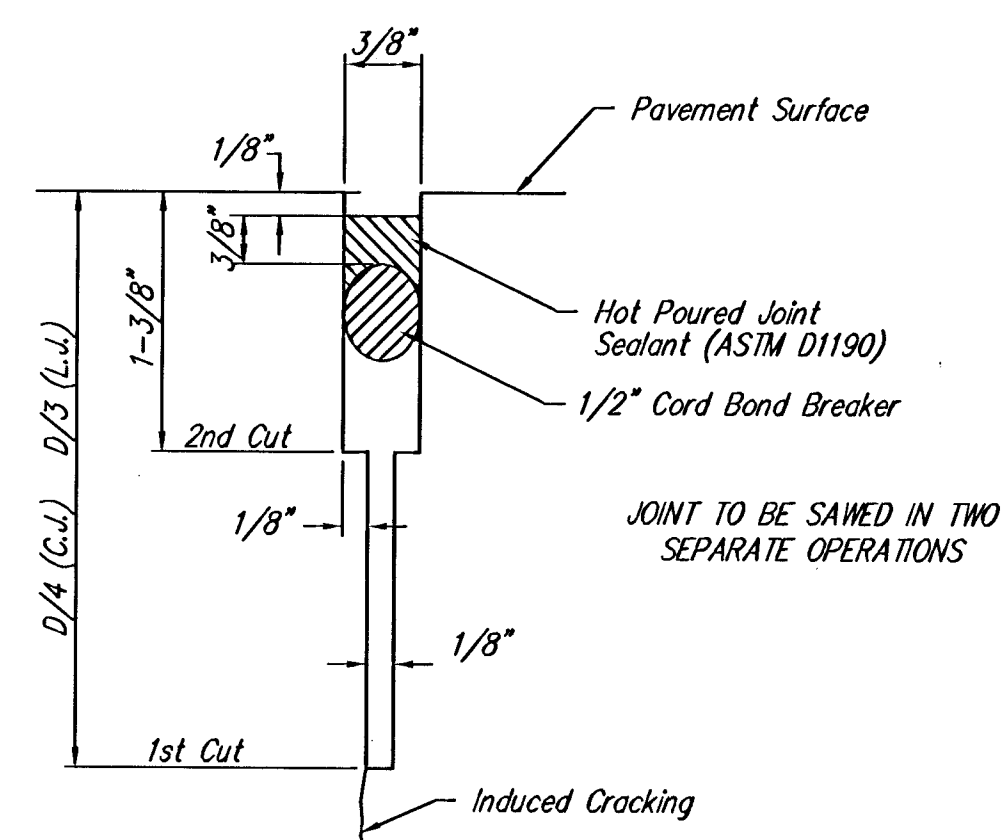

SAW JOINT DETAIL

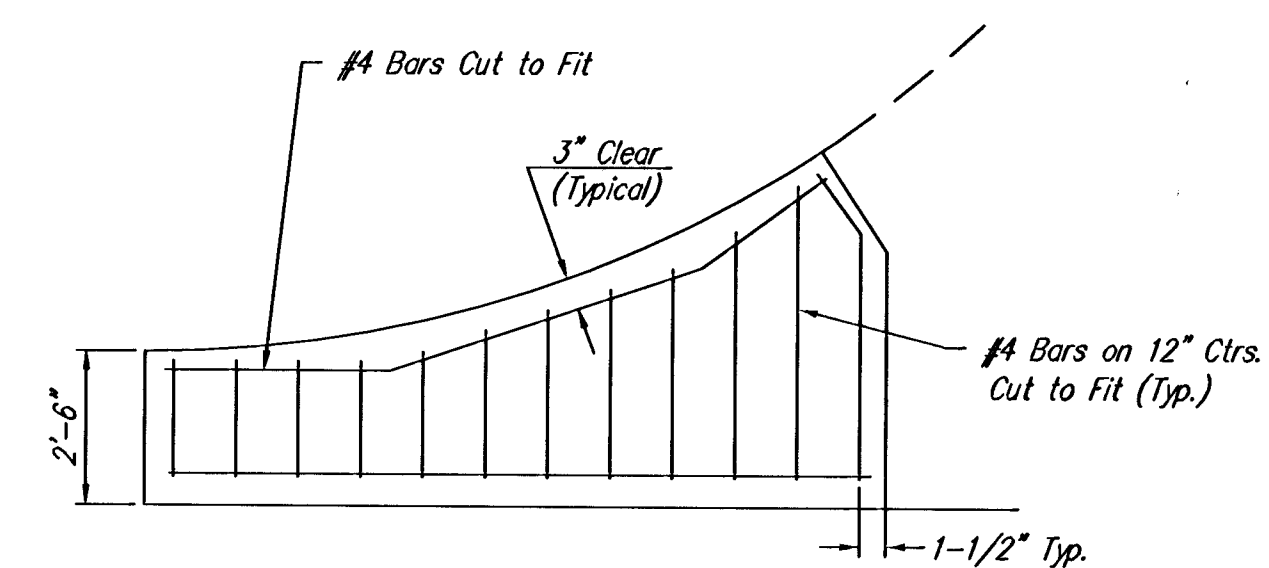

WING REINFORCING DETAIL

THE CITY OF WICHITA

CITY ENGINEER'S OFFICE  
CITY HALL - SEVENTH FLOOR  
425 NORTH MAIN STREET  
WICHITA, KANSAS 67202  
(316) 268-4501  
(316) 268-4114 FAX

**VALLEY GUTTER DETAILS**

JAMES L. ARMOUR, P.E. - CITY ENGINEER

PROJECT NUMBER 472-84213	INDEX CODE 735937
DATE SEPTEMBER 2005	SHEET NUMBER 4 / 22

G:\CIVIL\991118\dwg\PAVA\PH13 PART1\991118ED3