

**BENCHMARKS:**  
 135th St. W. & Pawnee  
 City of Wichita Benchmark Disc,  
 Northeast Corner of Intersection  
 On SW Corner of Concrete Base  
 of High Line Pole.  
 Elev. = 1359.65 NGVD29

City of Wichita Benchmark Disc,  
 0.4 Mi. South of Kellogg On  
 135th St. W., West Side of  
 Concrete Base for High Line  
 Pole, West of K.G.&E.  
 Substation, 135'± South of  
 Railroad Tracks On East Side of  
 135th St. W.  
 Elev. = 1367.77 NGVD29

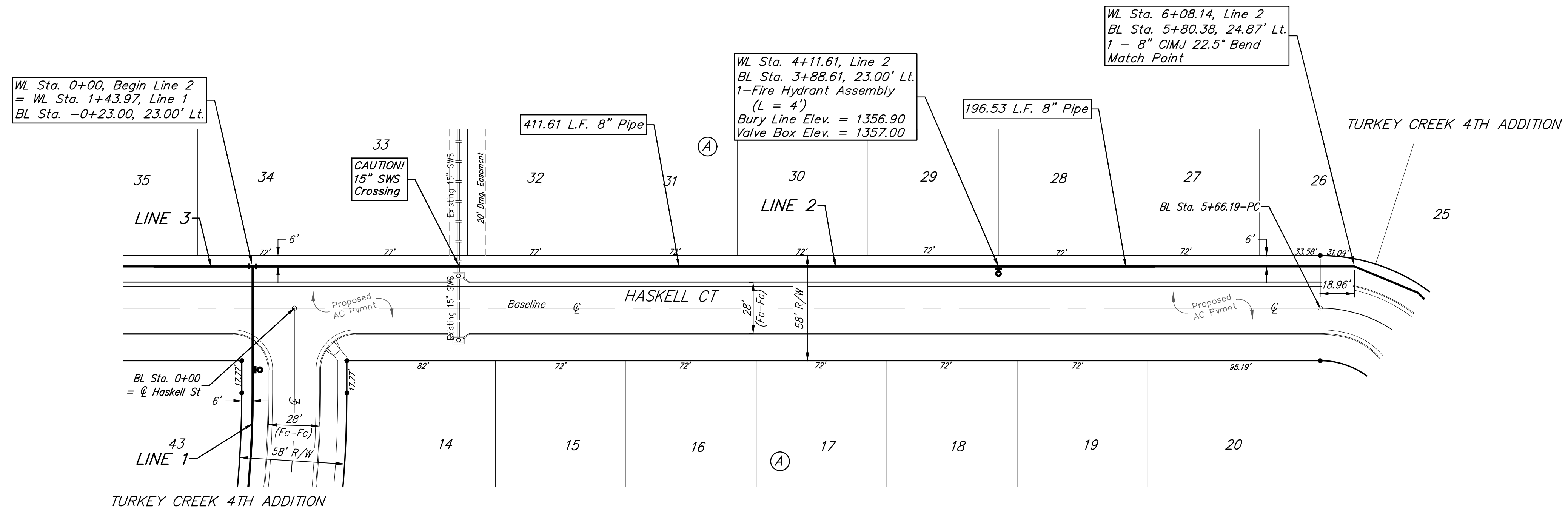

Baseline =  $\text{C}$  Haskell Ct

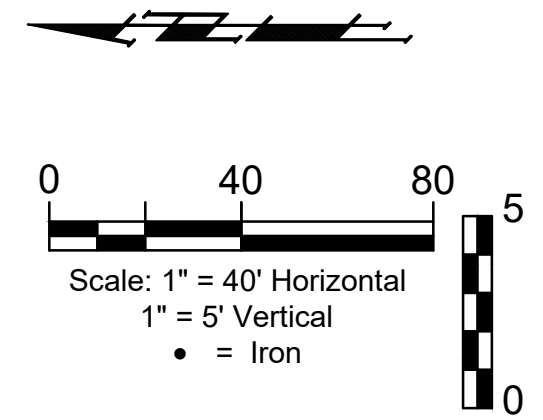
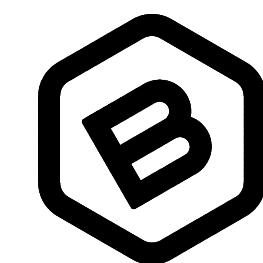
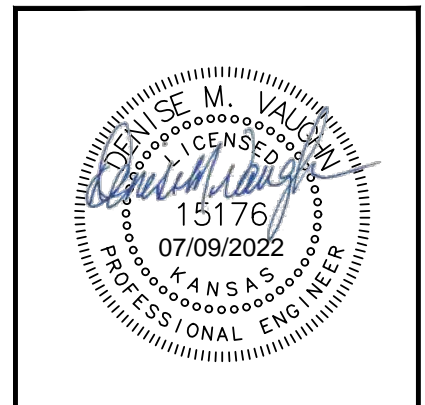
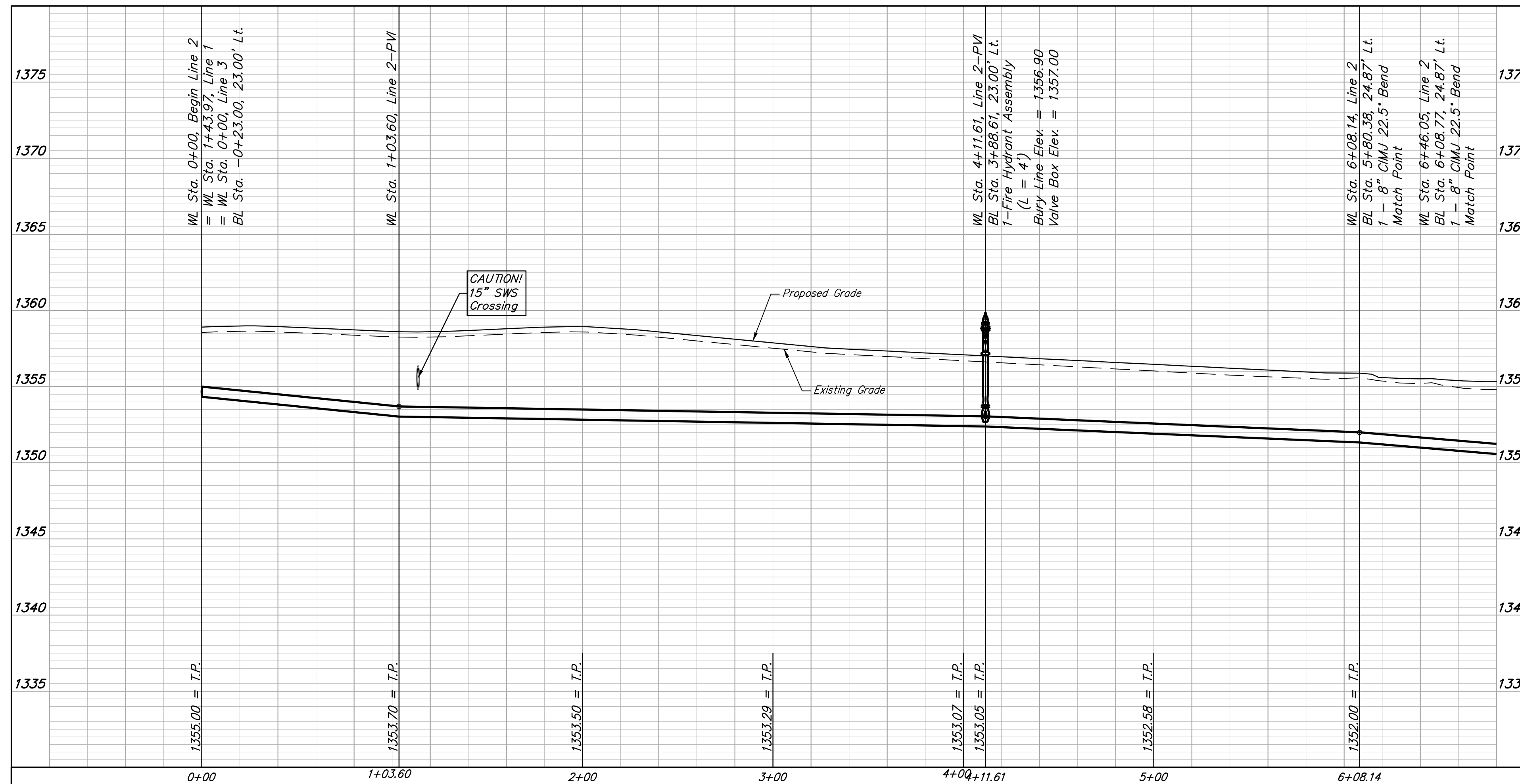

**BAUGHMAN  
 COMPANY**

315 Ellis St.  
 Wichita, KS 67211  
 316-262-7271  
 BaughmanCo.com

TURKEY CREEK 4TH  
 ADDITION - PHASE 1B

**LINE 2**

WATER DISTRIBUTION  
 SYSTEM

PROJECT NUMBER:  
 448-2020-016823

DESIGN: DMV DRAWN: JAK  
 DATE: June 23, 2022

SHEET **5** OF **16**