

PL010121: Friday, November 04, 2022 09:22AM

J:\PROJECTS\2022\01\10708_MPH_119TH\HAND37TH\DEVELOPMENT\SERVICES\02788_CAD\SHOTS\05_CIVIL\WTRPH1\10708-05-3200.DWG

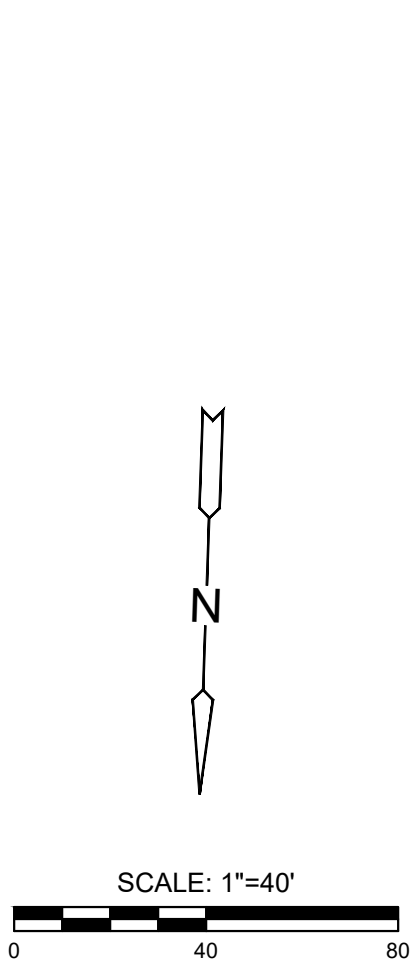

NOTE:
CONTRACTOR TO VERIFY LOCATION AND ELEVATION OF EXISTING WATER LINE PRIOR TO CONSTRUCTION.

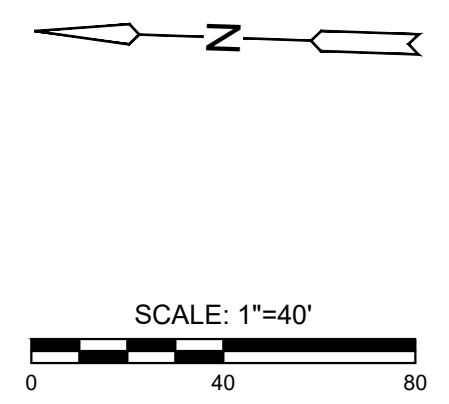
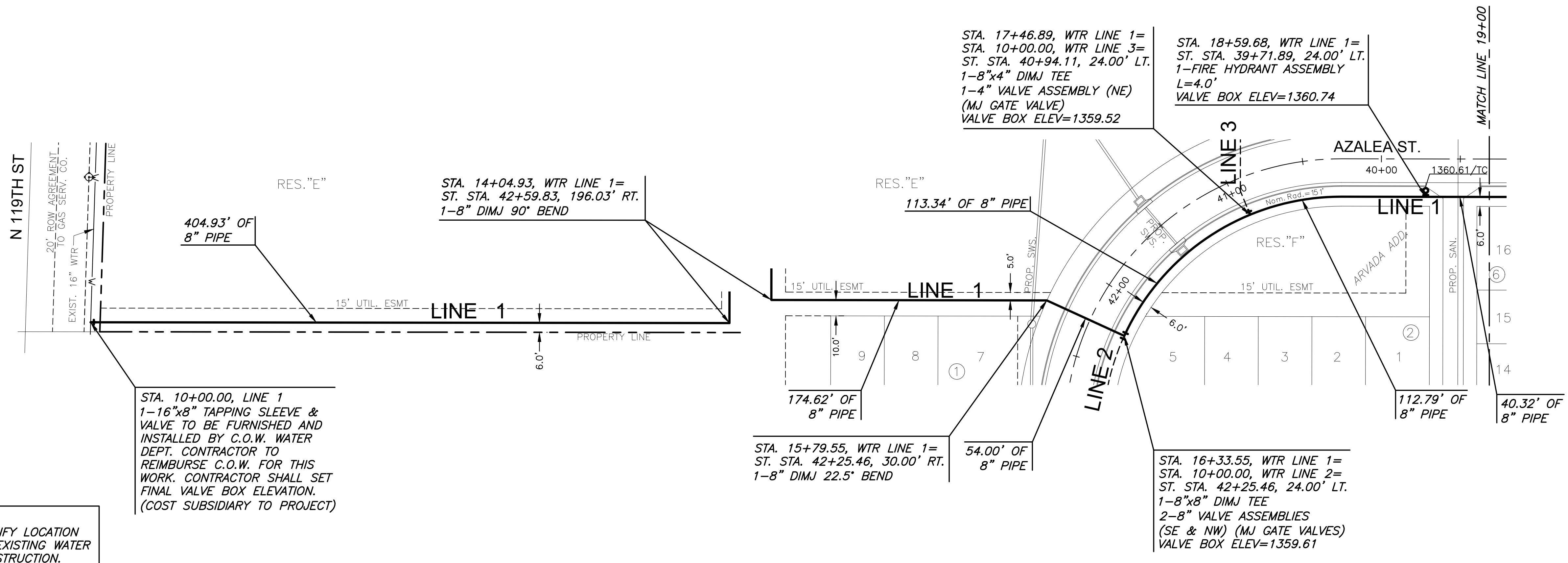

PLAN WTR LINE 1
PROFILE WTR LINE 1

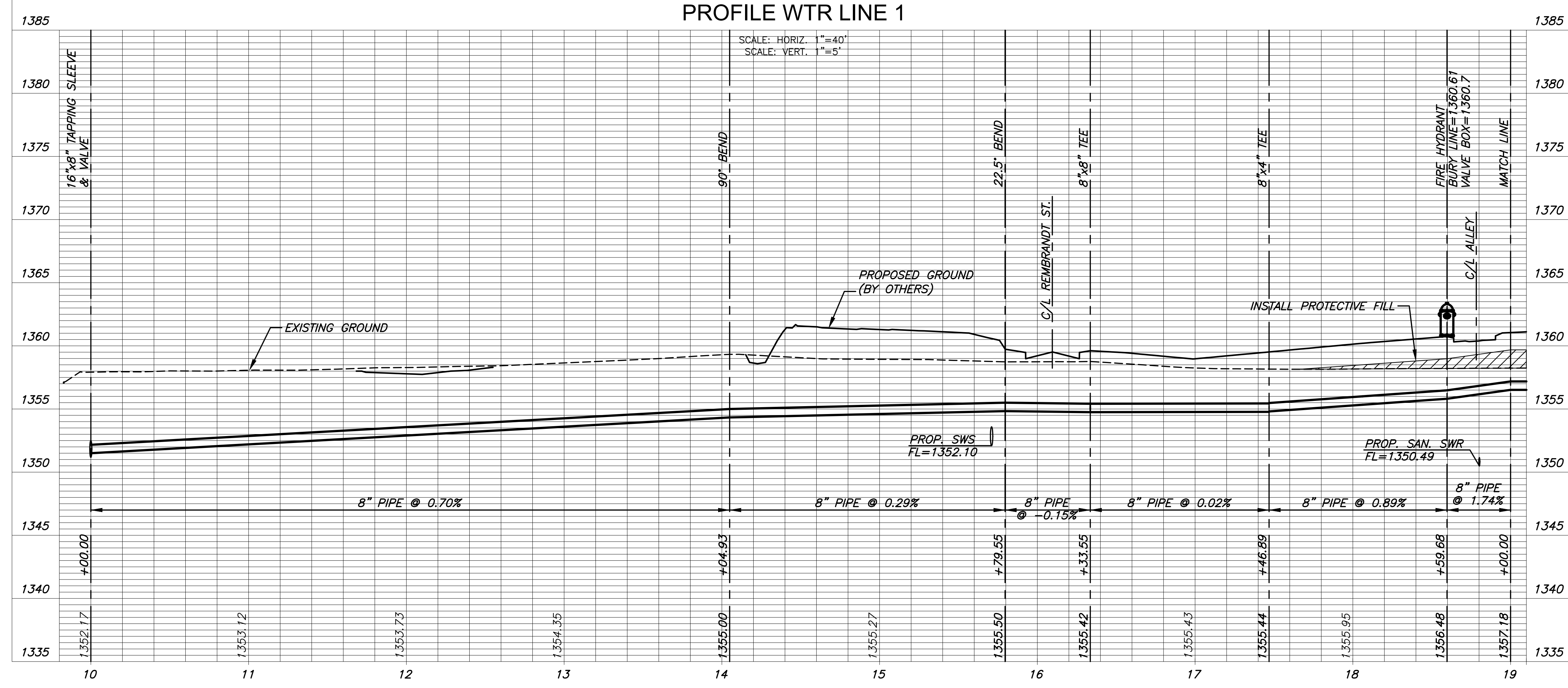

WATER DISTRIBUTION PLANS FOR
ARVADA ADDITION
PHASE 1

©2022 MKEC Engineering All Rights Reserved www.mkec.com
These drawings and their contents, including, but not limited to, all concepts, designs, & ideas are the exclusive property of MKEC Engineering (MKEC), and may not be used or reproduced in any way without the express consent of MKEC.

WTR LINE 1

PROJECT NO.	448-2022-024786	
DATE	NOV 2022	
SCALE	1"=40'	
DESIGNED	DRAWN	CHECKED
SPE	LM	SPE

NO.	REVISION	DATE

SHEET NO.
04 OF 17