

A
B
C
D
E

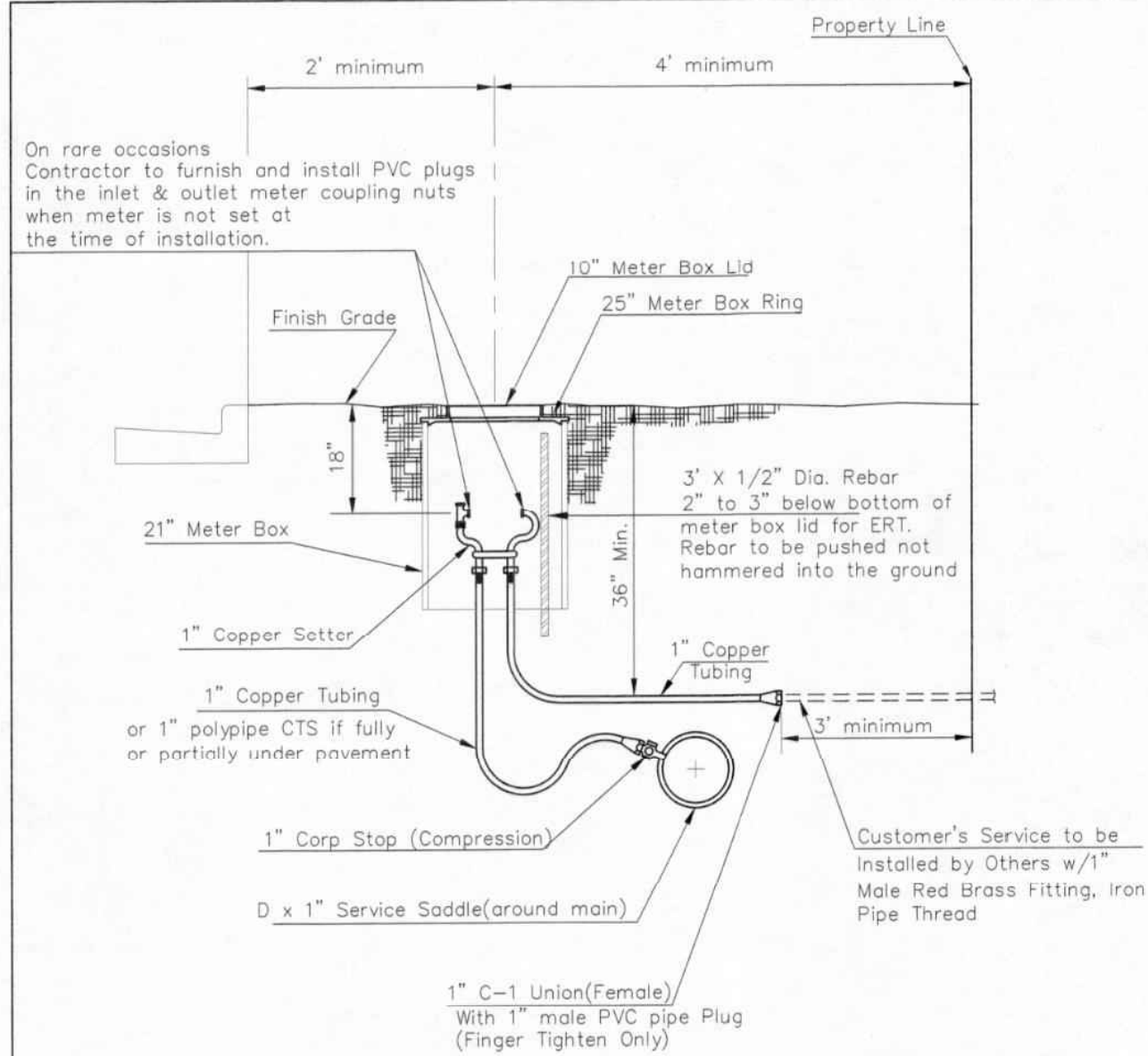

Minimum length of pigtail on consumer side is 36" of copper tubing from meter set.
Bore hole under paving shall be a maximum of 2" in diameter and a minimum of 3/8" below top of pavement.
Service Saddles are required on all mains.
Meter boxes will be located on each lot to be served, as indicated in the SPECIAL PROVISIONS

TYPICAL 1" METER SETTING

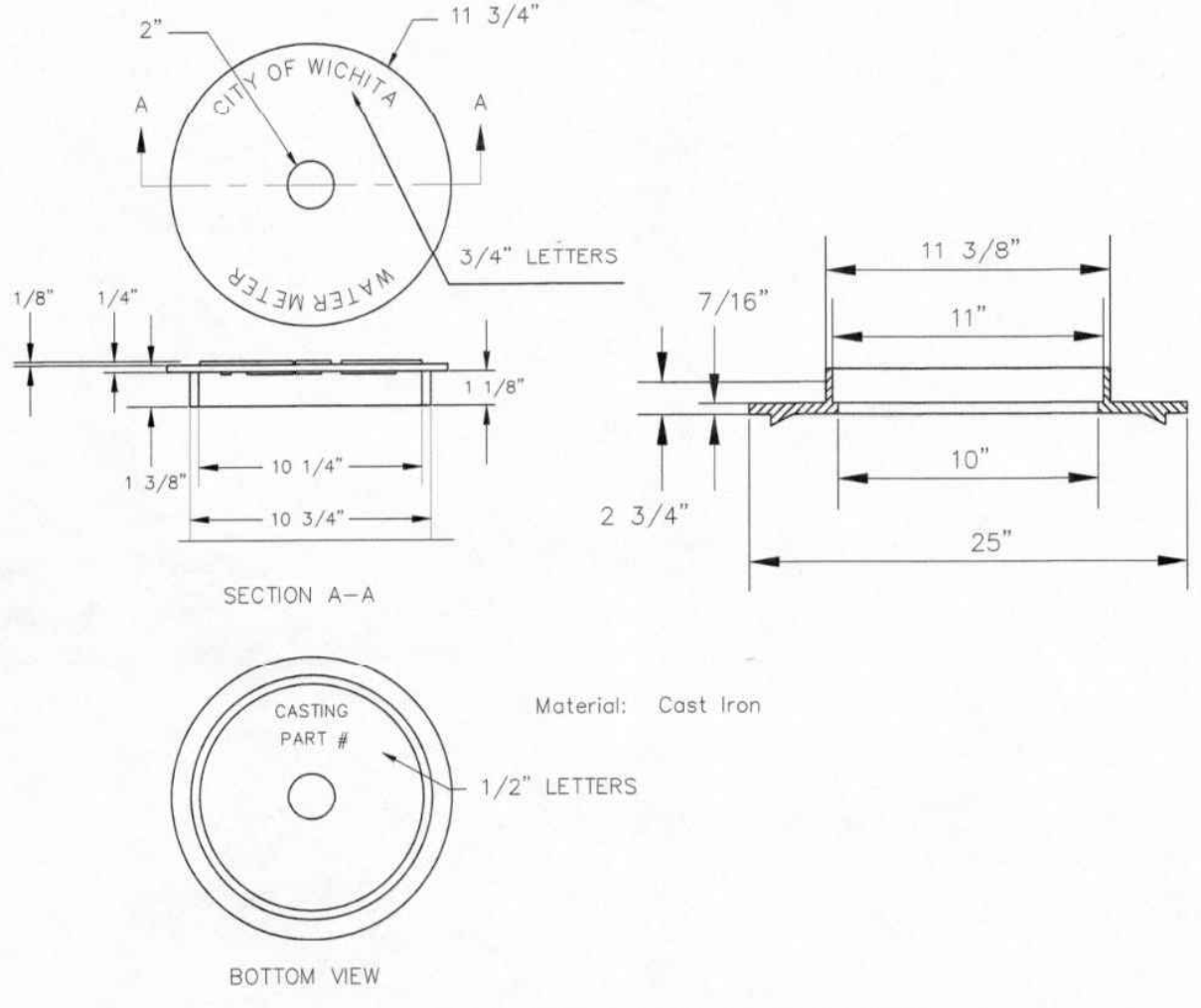

NOT TRAFFIC RATED RING & LID FOR 1" METER BOX

- 1 - 1/2" Mueller Thread Corporation Stop
- 1 - 1/2" Type "K" Copper Tubing
- 1 - 1/2" Copper to Iron Union (Male)
- 1 - 1/2" Brass Curb Stop (Iron to Iron)
- 2 - 1/2" x 1/4" Brass Nipple
- Air Release
- 2 - 1/2" Brass Elbows (90°)
- 1 - 1/4" Brass Nipple
- 1 - 30" Monitor Cover
- 1 - 20" Meter Lid

NOTE: THE 1 1/2" AIR RELEASE ASSEMBLY WILL TYPICALLY BE USED ON WATER MAINS 24" AND SMALLER, AS SPECIFICALLY DESIGNATED IN THE PLANS. COMBINATION AIR RELEASE ASSEMBLIES WILL BE SPECIFICALLY DESIGNED FOR PROJECTS WITH LARGER MAINS, AND WILL BE INCLUDED IN THE PLANS.

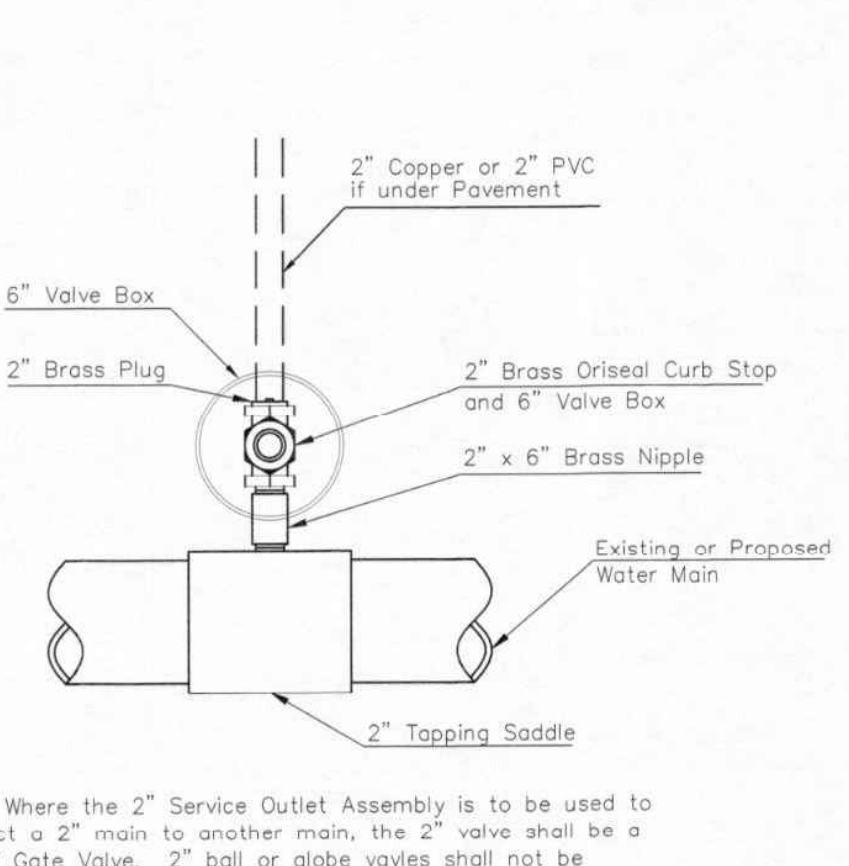

2" SERVICE OUTLET ASSEMBLY TOP VIEW

Note: Where the 2" Service Outlet Assembly is to be used to connect a 2" main to another main, the 2" valve shall be a 2" IPT Gate Valve. 2" ball or globe valves shall not be approved for this use.

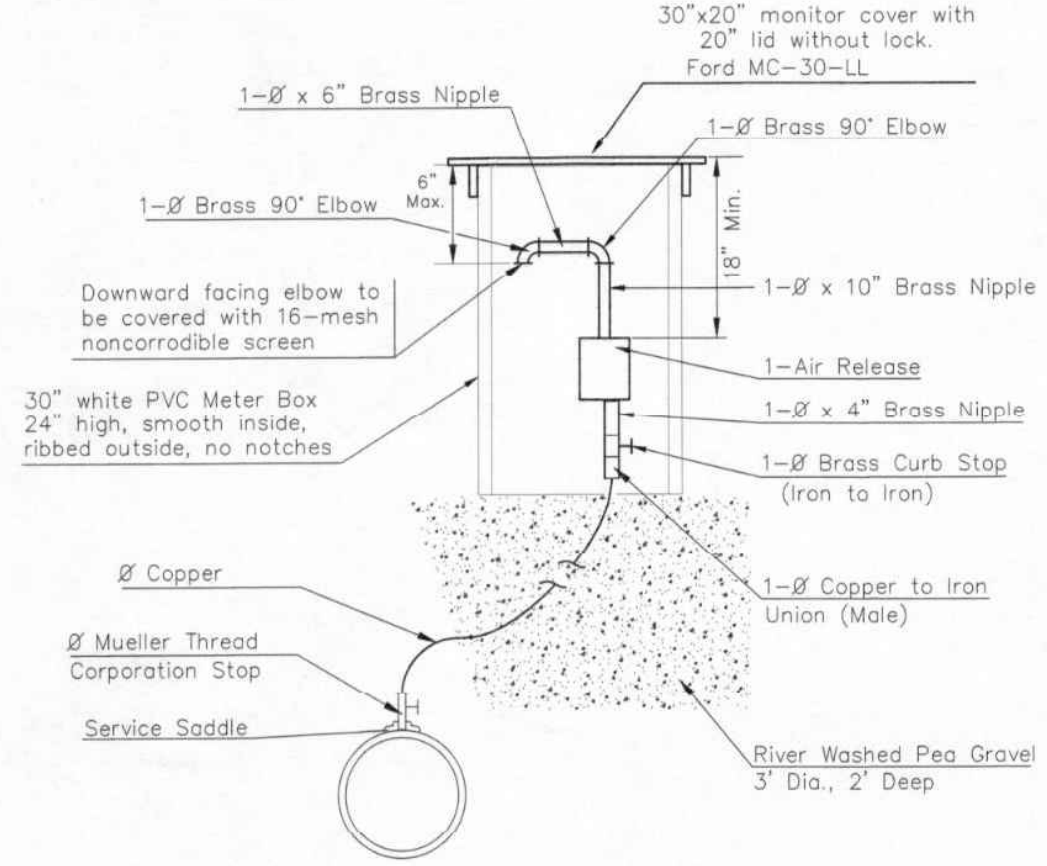

MATERIALS FOR 1" or 2" AIR RELEASE ASSEMBLY Ø = 1" or 2"

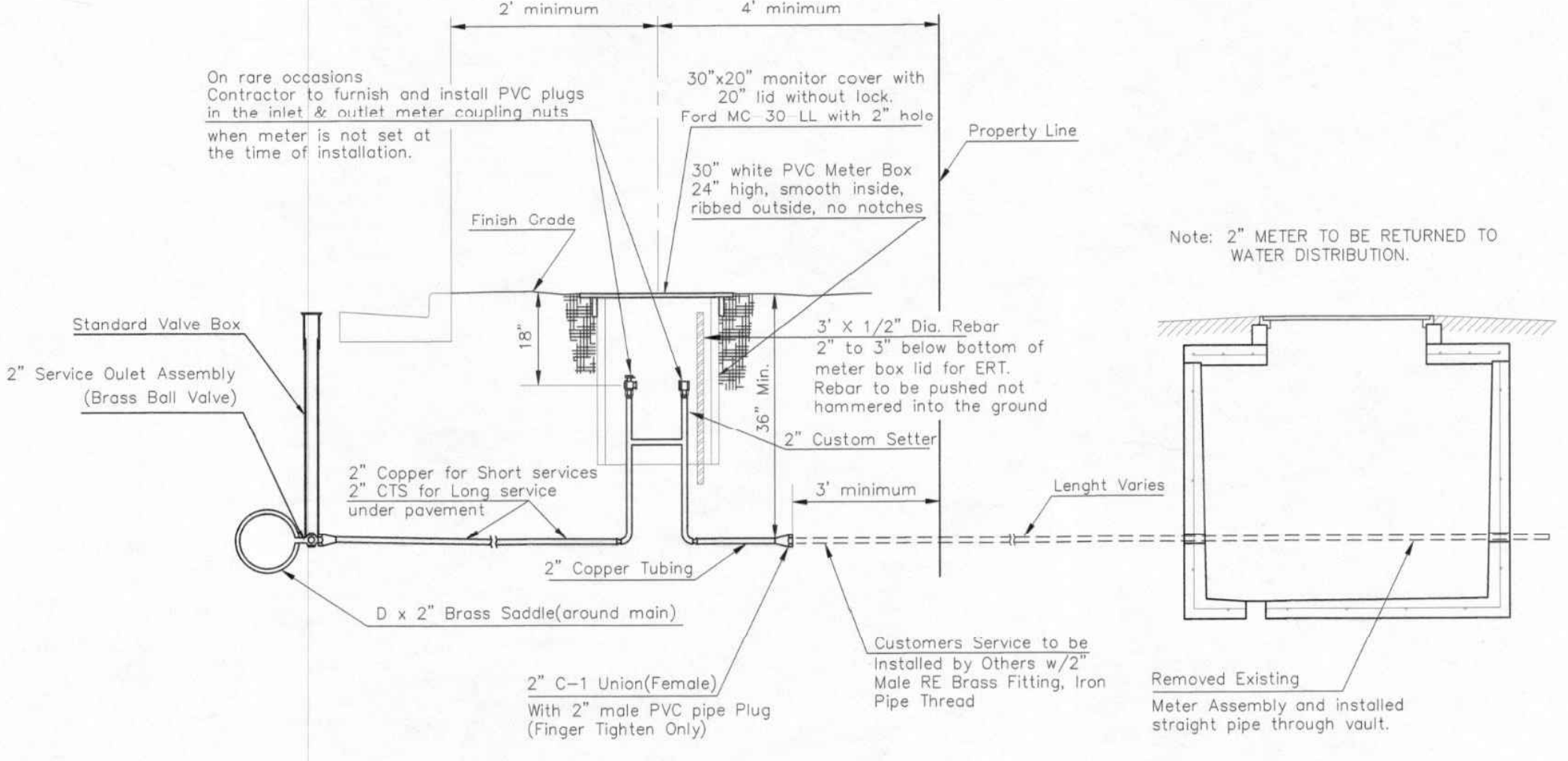

TYPICAL 2" METER SETTING

Note: ONE VALVE STEM EXTENSION FOR EACH VALVE BURIED GREATER THAN 5'.

TYPICAL 2" METER SETTING INVOLVING EXISTING 2" METER VAULT

Note: ONE VALVE STEM EXTENSION FOR EACH VALVE BURIED GREATER THAN 5'.

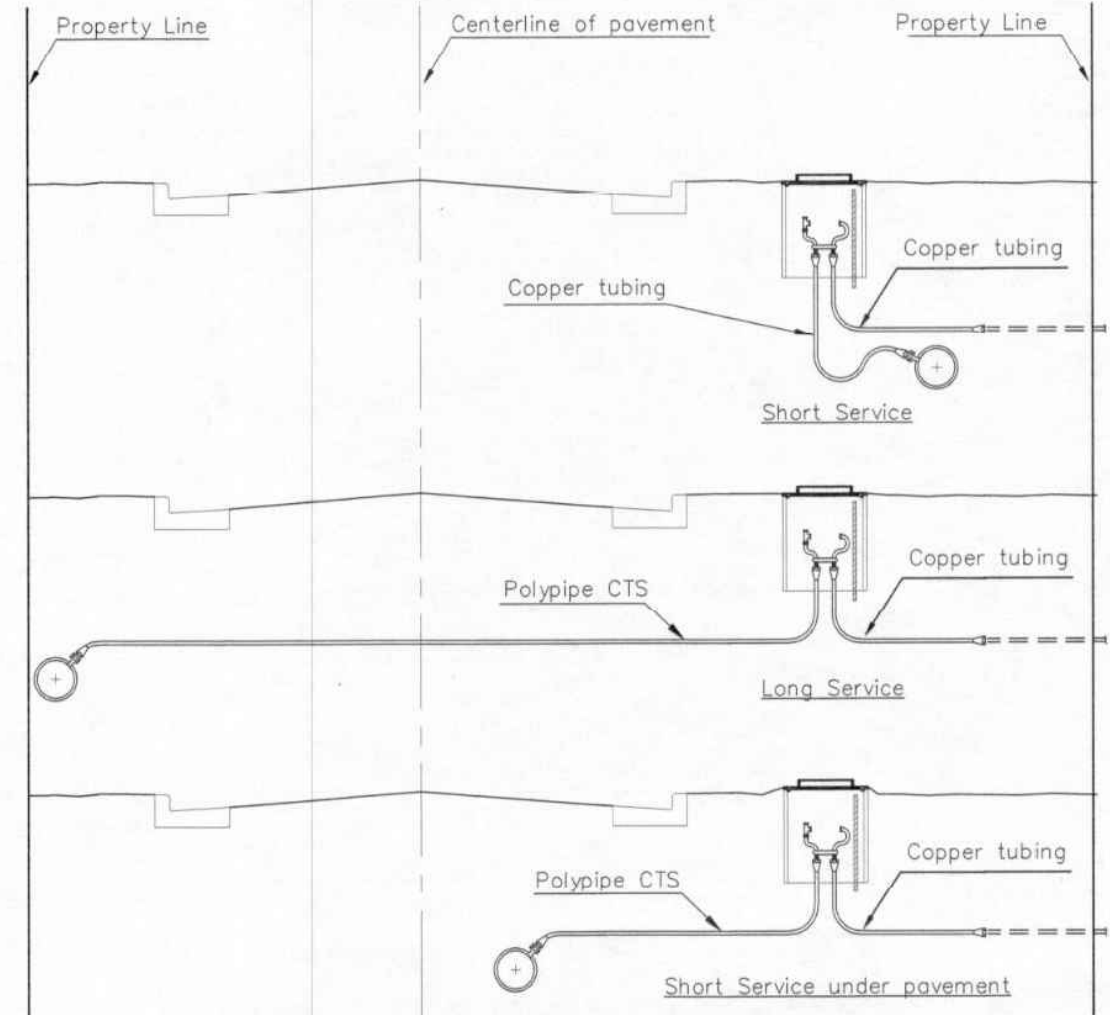

SERVICE TYPES

REVISED: NOVEMBER 2019	TM	3"x1/2" REBAR IN 1" & 2" METER SETTINGS FOR ERT.
CITY OF WICHITA		
STANDARD WATER SERVICE DETAIL		
CITY ENGINEER GARY JANZEN, P.E.		
PROJECT NUMBER	OCA NUMBER	DATE
CITY ENGINEER'S OFFICE CITY HALL - SEVENTH FLOOR 455 NORTH MAIN STREET WICHITA, KANSAS 67202-1620 (316) 268-4501		SHEET _ of _



WL-102

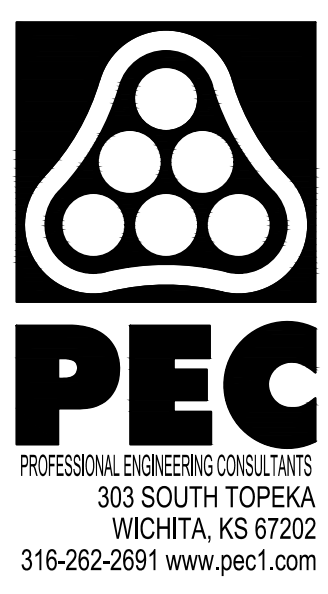

WATER MAIN IMPROVEMENTS

12" WATER MAIN ALONG 167TH ST. - W FROM MAPLE STREET TO HARMONY STREET

PAUL GUNZELMAN, P.E. - CITY ENGINEER
CITY OF WICHITA PROJECT NO. 448-2023-021493

JOB NO.	210975-008
DATE	SEPTEMBER 2023
PM	GAS
DESIGNED BY	KJW
DRAWN BY	AJH
CHECKED BY	AMD
STANDARD WATER SERVICE DETAIL	

CU-503

SAVED 9/22/2023 1:47:57 PM BY CATHY LINK
PLOTTED 10/17/2023 9:00:39 AM BY KURTIS DEKAT
U:\WICHITA-CIVIL\2023\12\10975008\PEC\DRAWINGS\210975-008-CU-503.DWG