

1/2" EXPANSION JOINT MATERIAL
w/ SEALANT COLORED TO MATCH
ADJACENT SIDEWALK

ARKANSAS RIVER

GANDER MOUNTAIN
(UNDER CONSTRUCTION)

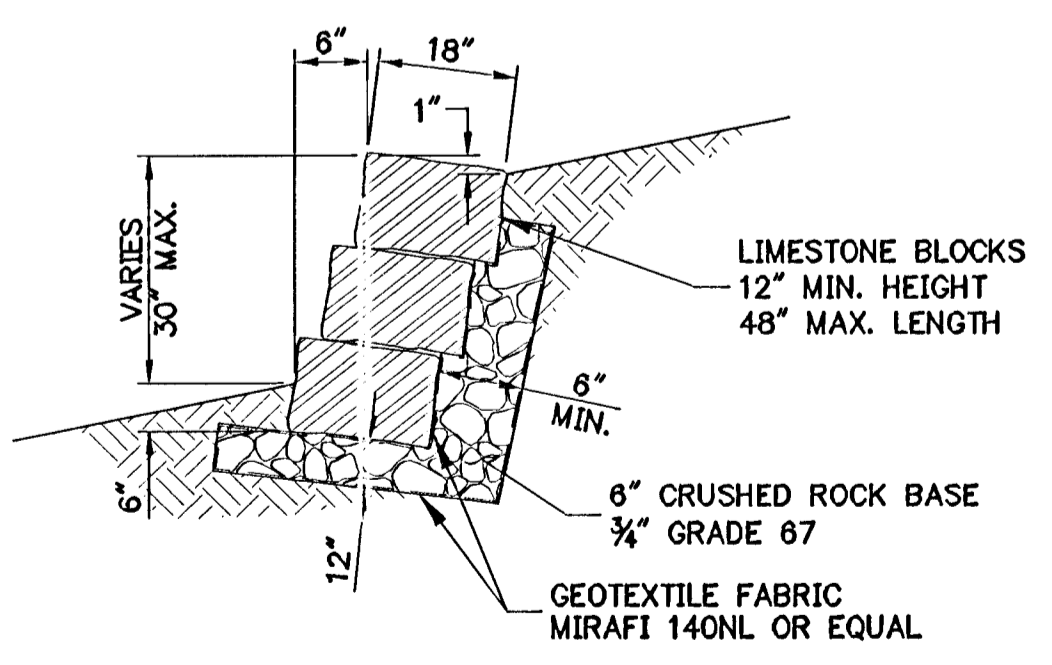

TYPE "B" WALL
SCALE: N.T.S.

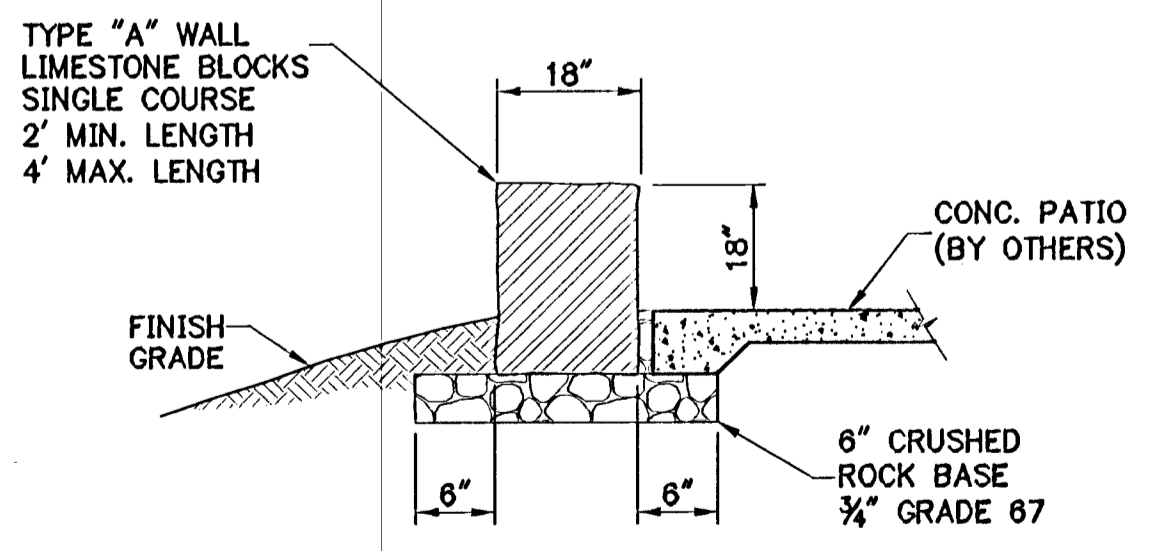

TYPE "A" WALL
LIMESTONE BLOCKS
SINGLE COURSE
2' MIN. LENGTH
4' MAX. LENGTH

PATIO WALL DETAIL
SCALE: N.T.S.

NOTE:
DIMENSIONS ARE PARALLEL AND PERPENDICULAR
TO EXISTING RIVER EDGE PILE CAP.

LEGEND

- COLORED CONCRETE PAVEMENT
COLOR "SOMBRERO BUFF"
SCOFFIELD #0-25
- COLORED CONCRETE PAVEMENT
COLOR "SHADOW SLATE"
SCOFFIELD #0-31
- TYPE "C" LIGHTPOLE & BASE
RE: ELECTRICAL PLANS
- SECTION LETTER
A
C1.1/C1.1

PLAN SHEET DETAIL IS CUT ON

PLAN SHEET DETAIL IS SHOWN ON

Gossen Livingston
Architecture
420 South Emporia
Wichita, KS 67202
Tel: (316) 265-9367
Fax: (316) 265-5646
Email: arch@gljll.com

© 2005 Gossen Livingston Associates, Inc.
The drawing and all information herein is the exclusive property of Gossen Livingston Associates, Inc. and is not to be copied or used in any way without the express written consent of Gossen Livingston Associates, Inc. All drawings, specifications, ideas, designs and arrangements appearing herein constitute the original and unpublished work of:
Gossen Livingston Associates, Inc.

Johnson & Associates, Inc.
100 E. California Ave. - Third Floor
Oklahoma City, OK 73104
(405) 235-8075 FAX (405) 235-8078
Certificate of Authorization #E-1128 EXP. DATE: 12-31-2005

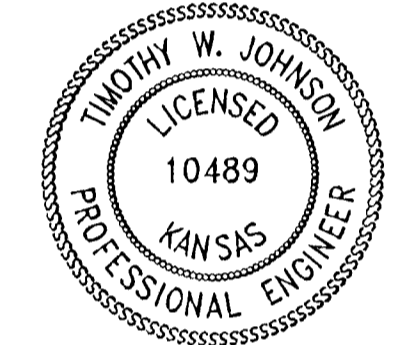

WICHITA
WATERWALK

**PUBLIC IMPROVEMENTS
PHASE 1A**

Mark	Date	Description

**RIVER EDGE SIDEWALK
DIMENSIONAL PLAN**

Job No.	C1.1
Date	06-16-05
Drawn	B.C.
Checked	P.B.

OF
7
Dwg. **5** of **23**