

SECONDARY WALL SECTION
NO SCALE

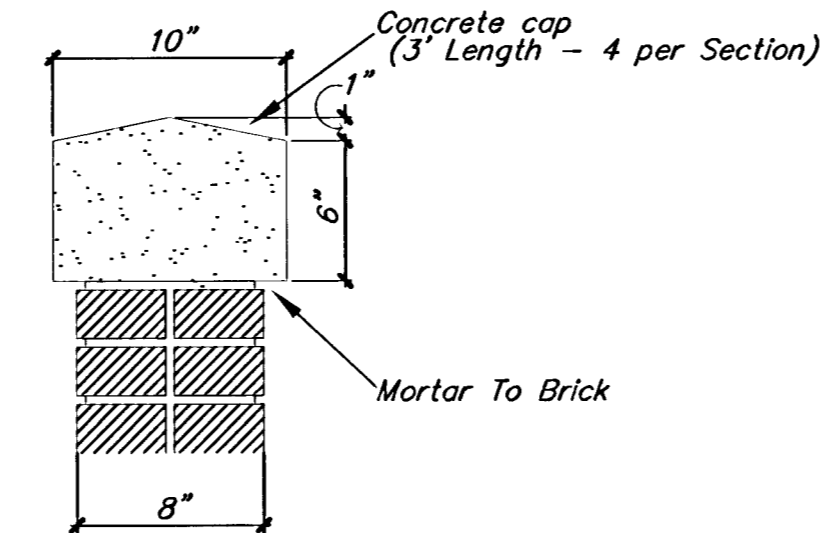

CONCRETE CAP
NO SCALE

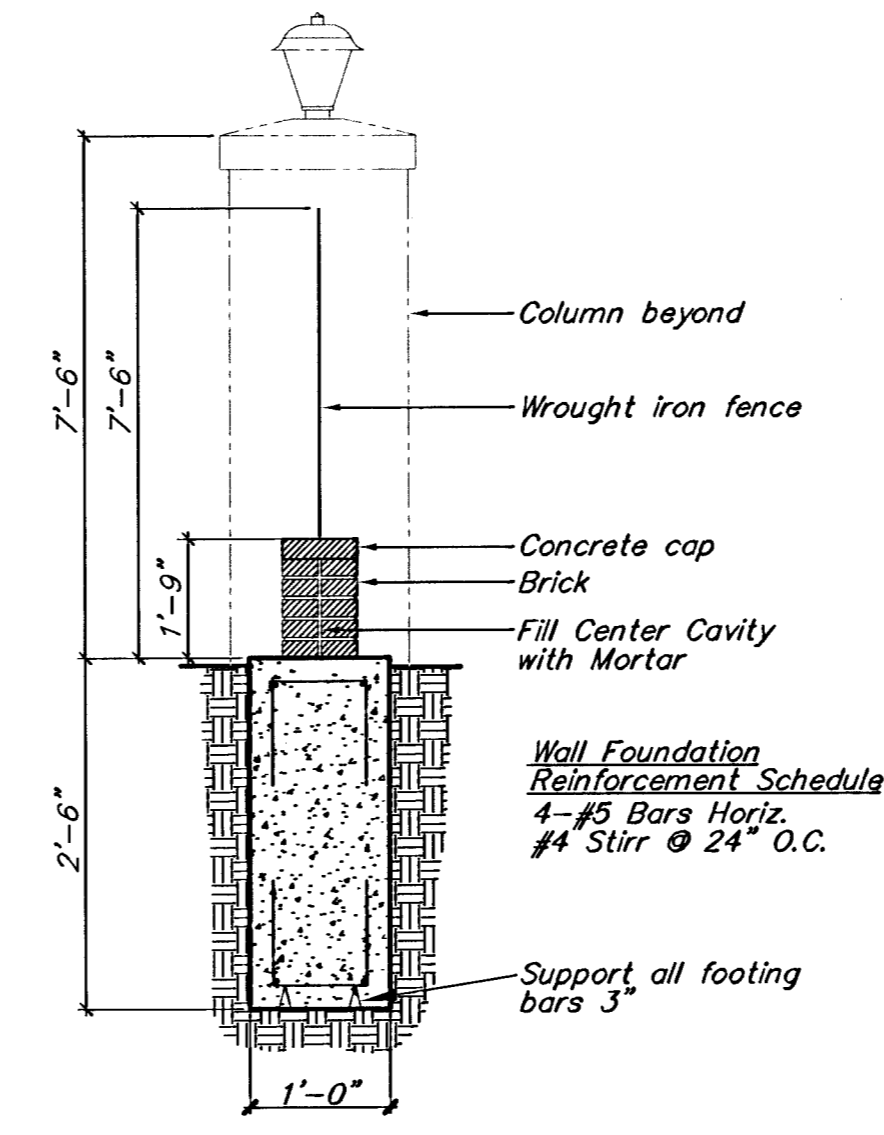

MAJOR WALL SECTION
NO SCALE

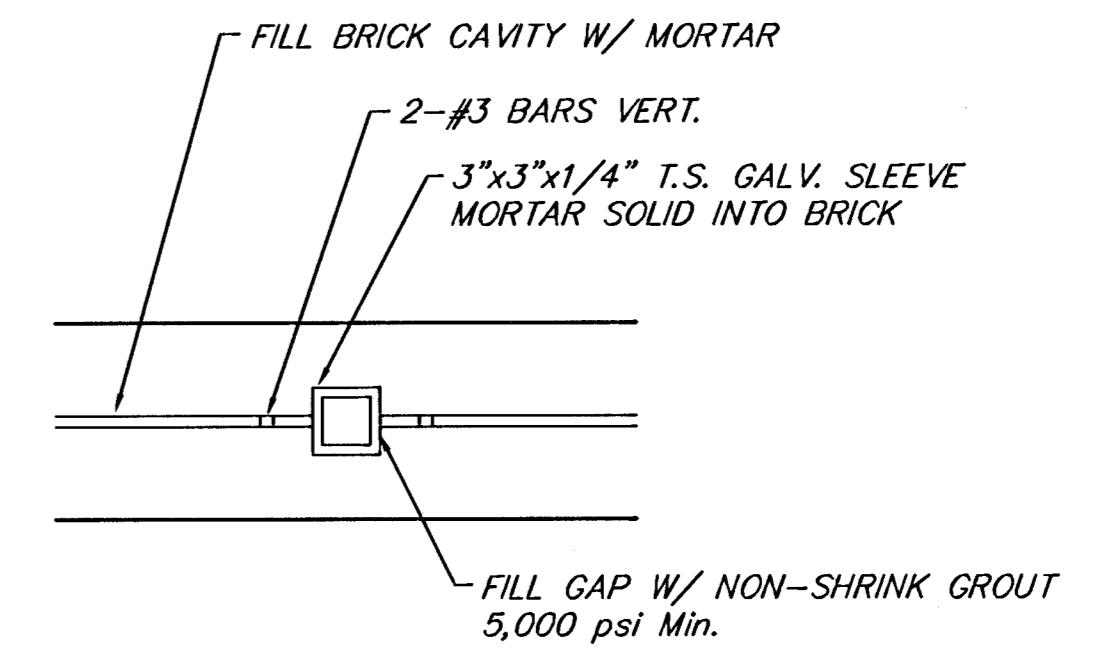

SLEEVE PLAN FOR CENTER POST
NO SCALE

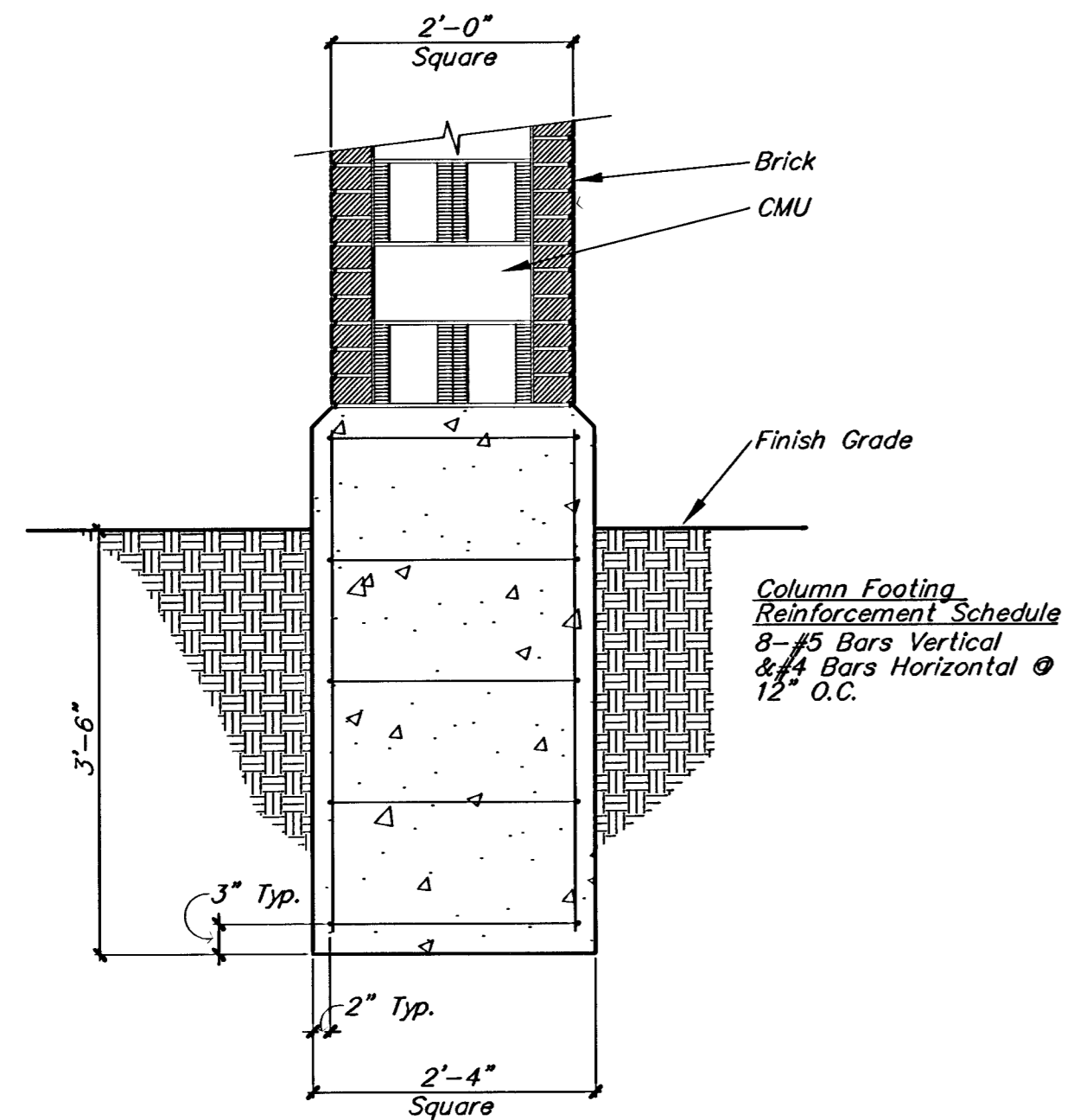

COLUMN SECTION & FOOTING
NO SCALE

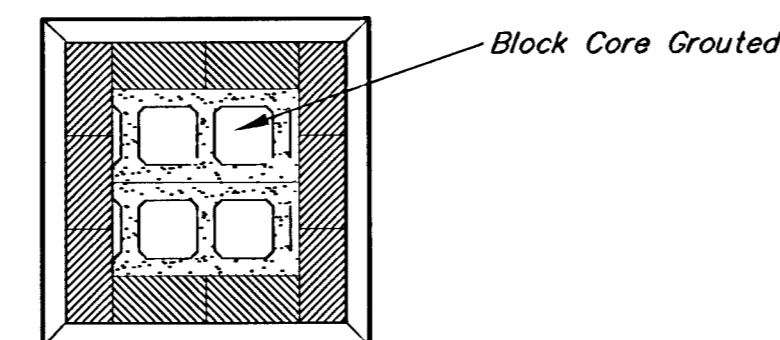

COLUMN BLOCK PLAN
NO SCALE

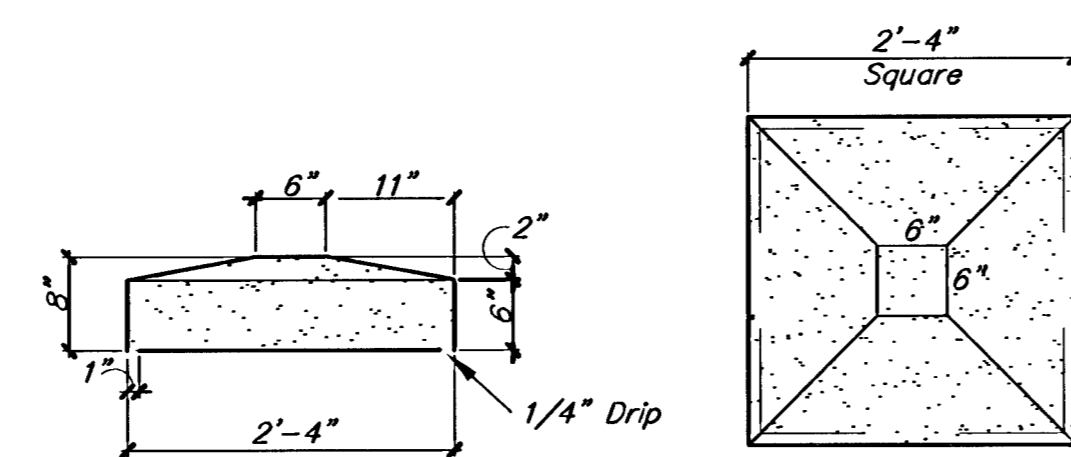

PLAN & SECTION CONCRETE CAP & PIER
NO SCALE

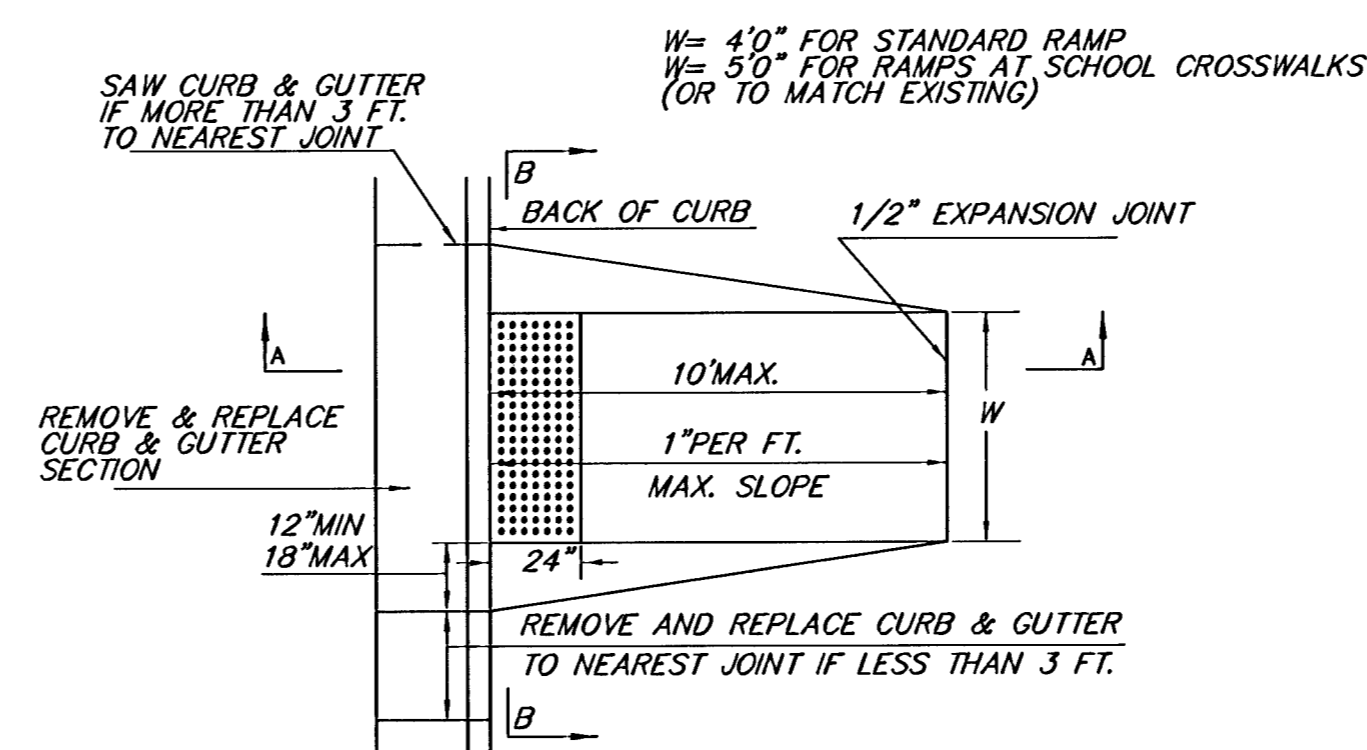

SECTION A-A

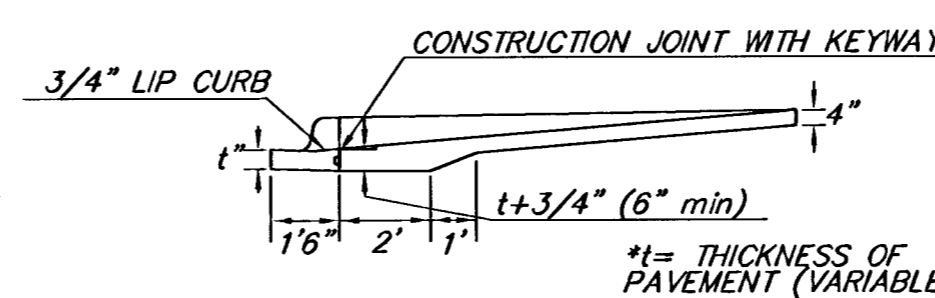

SECTION B-B

STANDARD WHEELCHAIR RAMP DETAIL
NO SCALE

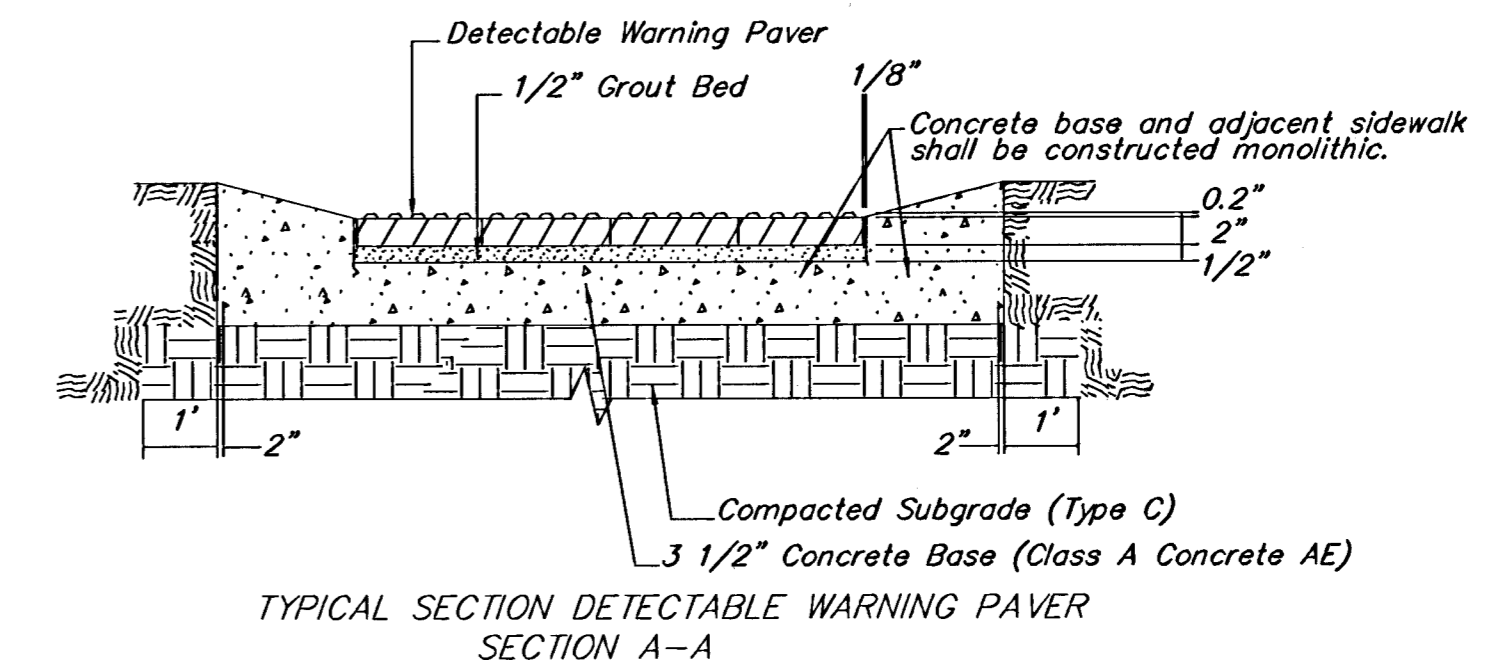

TYPICAL SECTION DETECTABLE WARNING PAVER
SECTION A-A

NOTE: HANOVER DETECTABLE WARNING PAVERS (OR AN APPROVED ALTERNATE) SHALL BE USED IN ALL WHEELCHAIR RAMPS. THE 11 3/4" RED 15' PAVER SHALL BE USED IN ALL APPLICATIONS.
HANOVER ARCHITECTURAL PRODUCTS
240 BENDER ROAD
HANOVER, PA 17331
1-717-637-0500
www.hanoverpavers.com

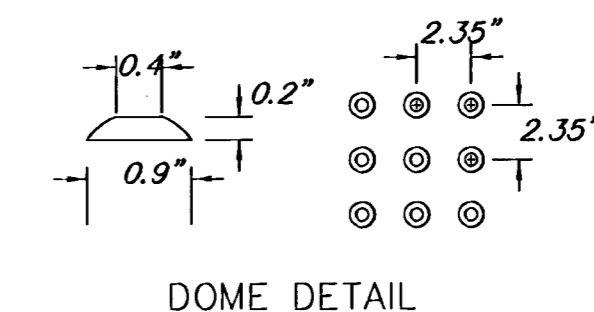

DOMES DETAIL

REV. 8-25-03
REV. 7-23-03

**PARKING LOT PLAN - KANSAS PAINT
ALT. SCREEN WALL & WHEEL CHAIR RAMP DETAILS
WICHITA, KANSAS**

	Ruggles & Bohm, P.A. Engineering, Surveying, Land Planning		DESIGN TCR	SHEET 4 OF 11
	924 North Main Wichita, Kansas 67203 www.rbkansas.com		(316) 264-8008 (316) 264-4621 fax E-mail: info@rbkansas.com	
DRAWING FILE Condnet2		PROJECT NUMBER 472-83846		DATE July 17, 2003