

PLAN

- Notes:
- Inlet Top Reinforcing shall be Spaced on 6" Max. Centers. Inlet Lids shall be Notched out as Indicated to Facilitate Construction of Curb.
 - b₃ Bar to be Field Bent to Clear Inlet Frame.

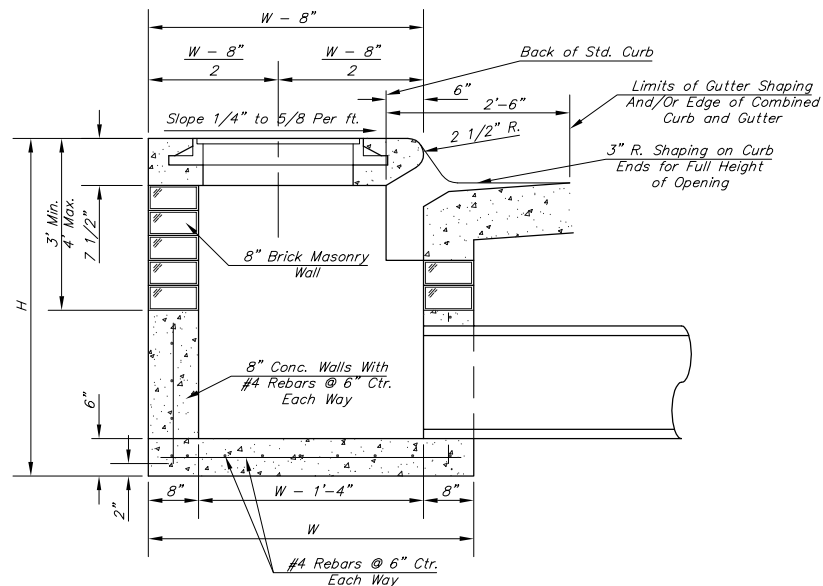

SECTION A-A

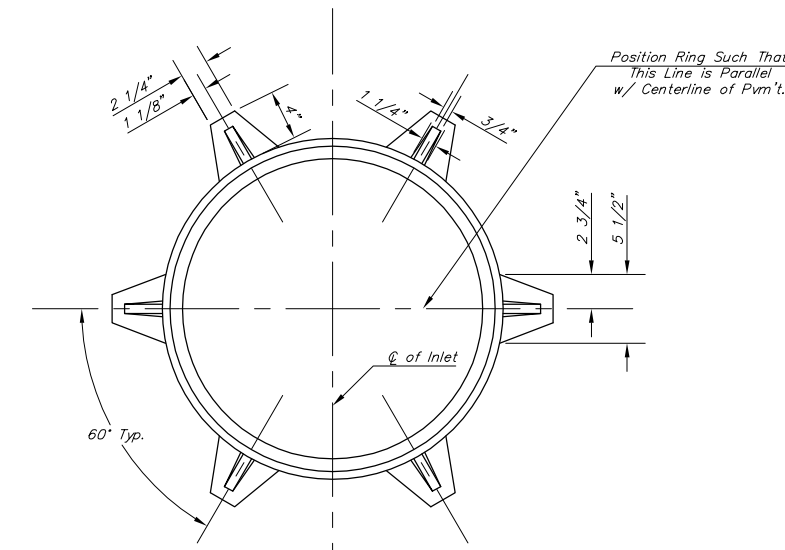

MANHOLE RING AND COVER

*See City of Wichita Standard Manhole Ring and Cover Detail Sheet for Cover Details to Be Used With Inlet Frame.

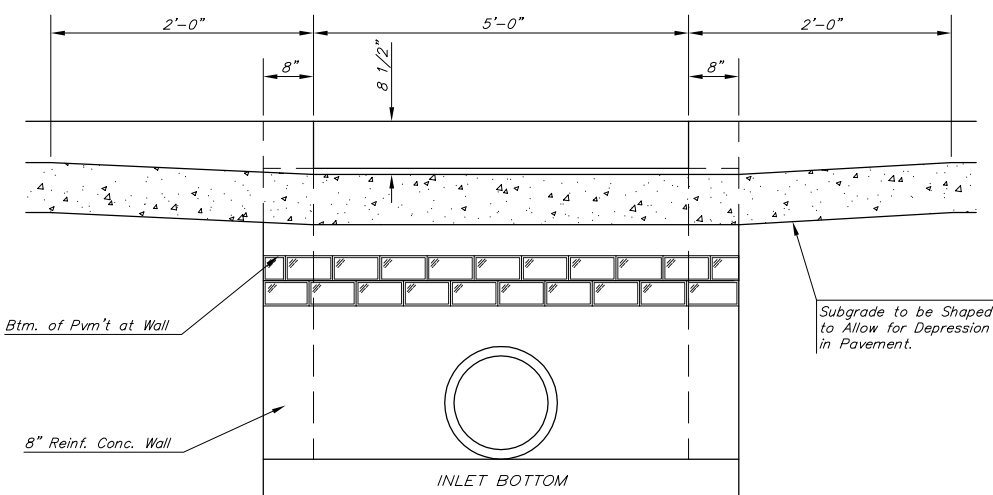

SECTION C-C

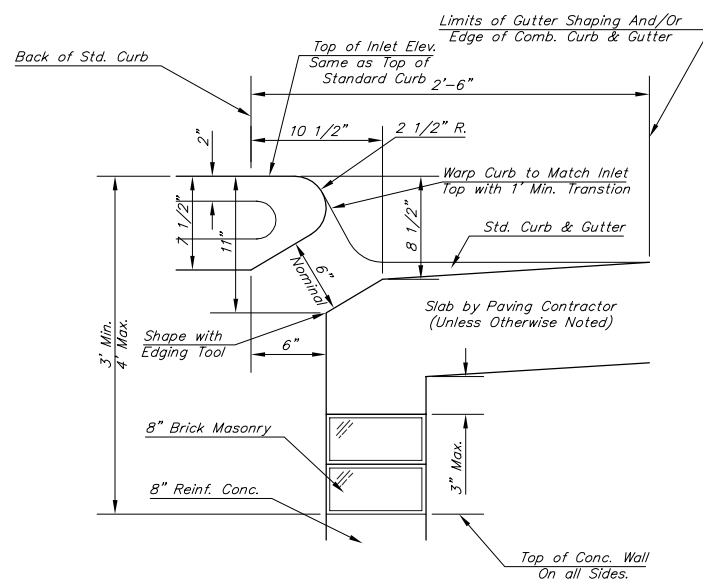

SECTION B-B

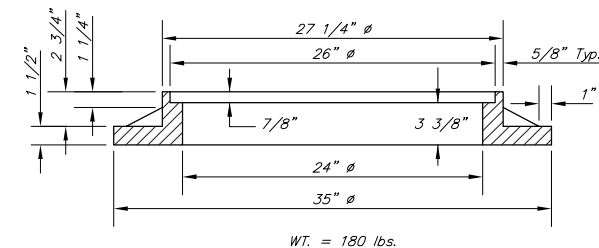

WT. = 180 lbs.

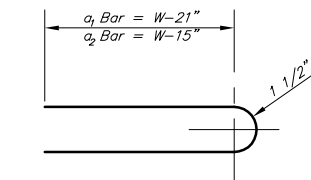

BENDING DIAGRAM

STEEL SCHEDULE

BAR NUMBER	a ₁	a ₂	a ₃	b ₁					b ₂	b ₃	b ₄	Wt. Lbs.
				W=4'-4"	W=5'-4"	W=6'-4"	W=7'-4"	W=8'-4"				
4	4	2	1	3	5	7	9	6	1	1		
SIZE	#4	#4	#4	#4	#4	#4	#4	#4	#4	#6		
LENGTH	W=4'-4"	5'-7"	6'-7"	4'-0"	6'-1"	-	-	-	1'-9"	6'-2"	4'-8"	60±
	W=5'-4"	7'-7"	8'-7"	5'-0"	6'-1"	-	-	-	1'-9"	6'-2"	4'-8"	81±
	W=6'-4"	9'-7"	10'-7"	6'-0"	-	6'-1"	-	-	1'-9"	6'-2"	4'-8"	101±
	W=7'-4"	11'-7"	12'-7"	7'-0"	-	-	6'-1"	-	1'-9"	6'-2"	4'-8"	121±
	W=8'-4"	13'-7"	14'-7"	8'-0"	-	-	-	6'-1"	1'-9"	6'-2"	4'-8"	141±

Note: a₃ Bars to be Placed Approx. 2" Below Top of Inlet Cover.

STANDARD CURB INLET PRECAST TOPS

W	PRE-CAST TOP SIZE	PIPE SIZE	CU. YD. CONC.
4'-4"	3'-8" 6'-4" 7 1/2"	21" & SMALLER	0.38±
5'-4"	4'-8" 6'-4" 7 1/2"	24" & 30"	0.51±
6'-4"	5'-8" 6'-4" 7 1/2"	36" & 42"	0.64±
7'-4"	6'-8" 6'-4" 7 1/2"	48" & 54"	0.77±
8'-4"	7'-8" 6'-4" 7 1/2"	60" & 66"	0.90±

GENERAL NOTES

- Concrete tops to be installed on thin mortar cushion to insure full support along brick walls. Concrete tops may be cast in place or precast. Concrete used for inlet construction shall be concrete pavement mix.
- Contractor shall have the option of constructing 8" brick masonry walls between the concrete inlet base and top on this inlet when W=6'-4" and H=7'-0" or less.
- Inlet invert shall be shaped with 8 sack sand mix concrete to create flow channels and to increase hydraulic efficiency such that the inlet will be self cleaning between all inlet and/or outlet pipes.
- The ends of all pipes installed in inlets shall be cut off flush with the inside face of the inlet wall.

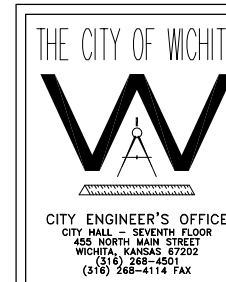

STANDARD TYPE 1
CURB INLET
OPENING = 6" x 5'-0"

M. E. LINDEBAK P.E. - CITY ENGINEER

PROJECT NUMBER: 468-84335
INDEX CODE: 751446

DATE: NOV 00
SHEET 6A OF 12