

EXPANSION JOINT

NOTE: Extra Thickness to be Subsidiary to Price of Square Yards Pavement

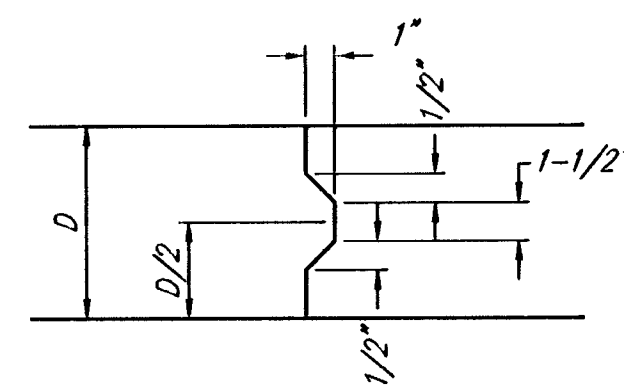

KEYWAY DETAIL

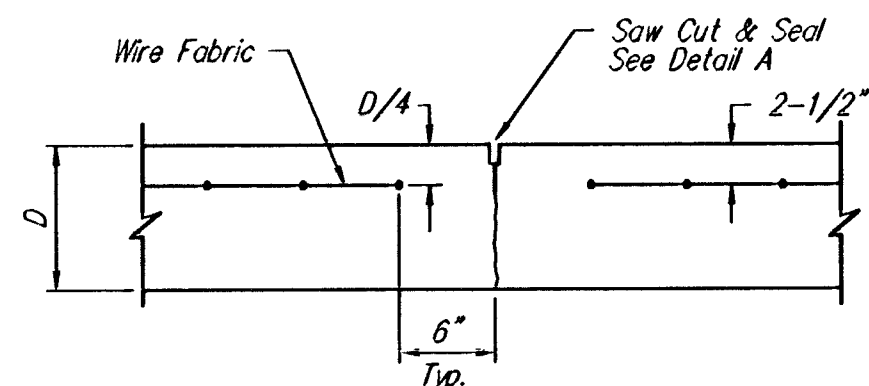

CONTRACTION JOINT DETAIL (C.J.)

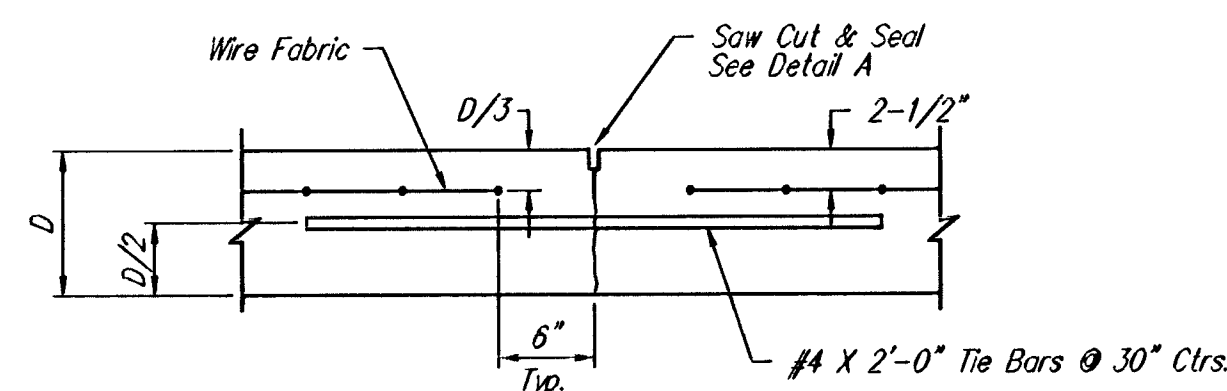

LONGITUDINAL JOINT DETAIL (L.J.)

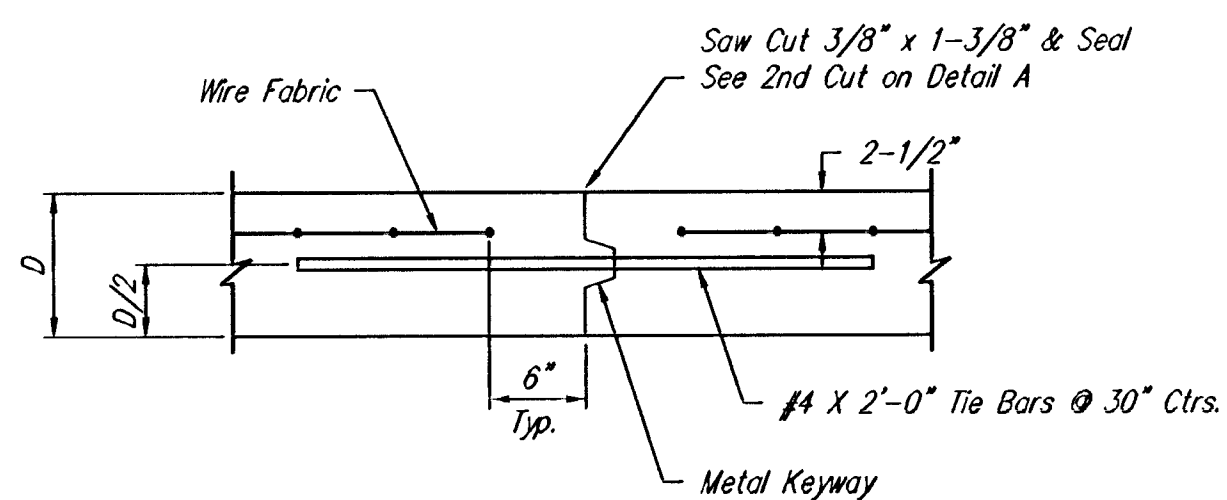

OPTIONAL LONGITUDINAL JOINT DETAIL (L.J.)

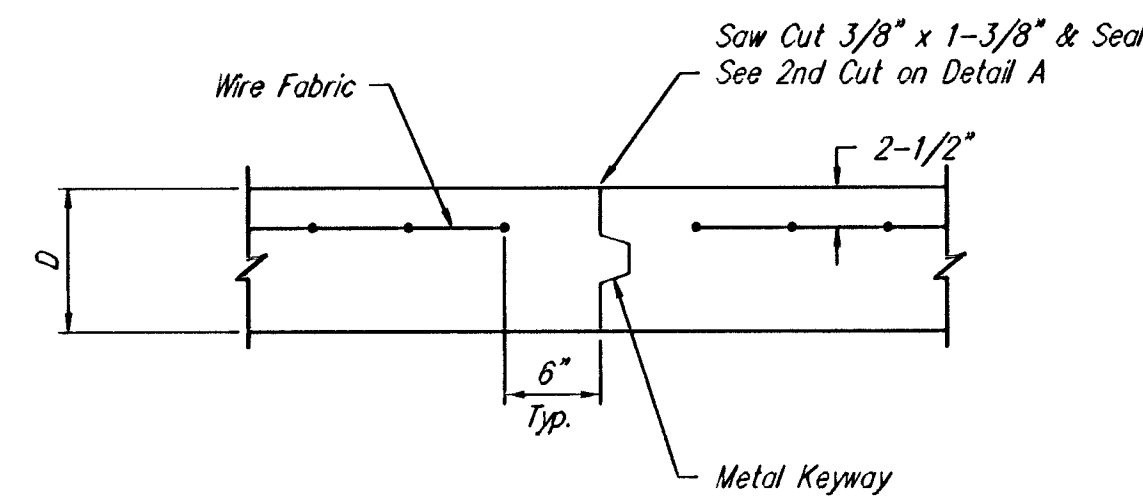

OPTIONAL CONTRACTION JOINT

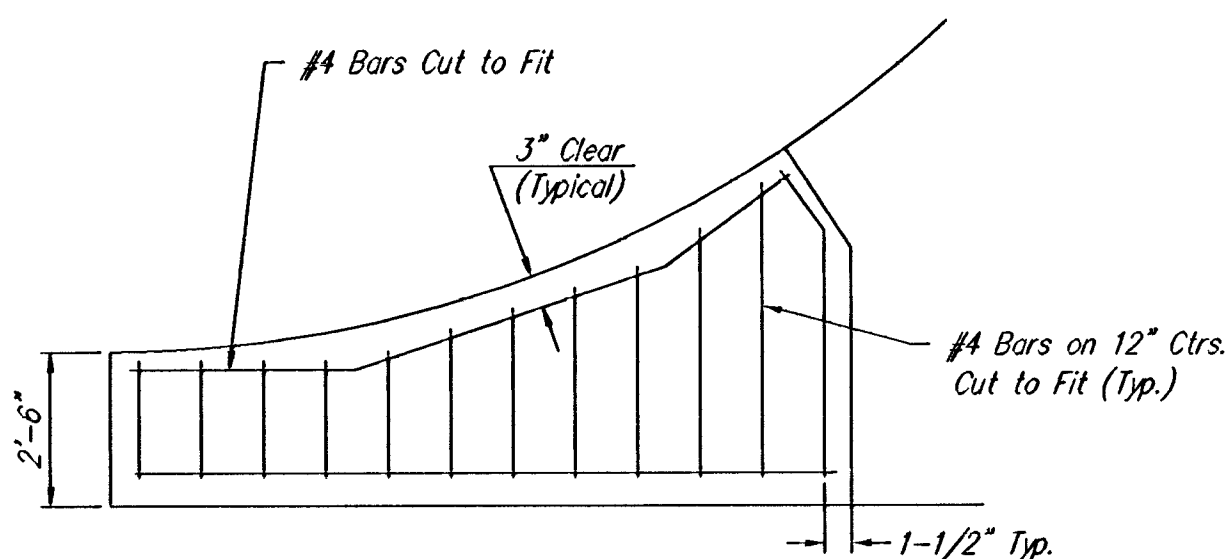

WING REINFORCING DETAIL

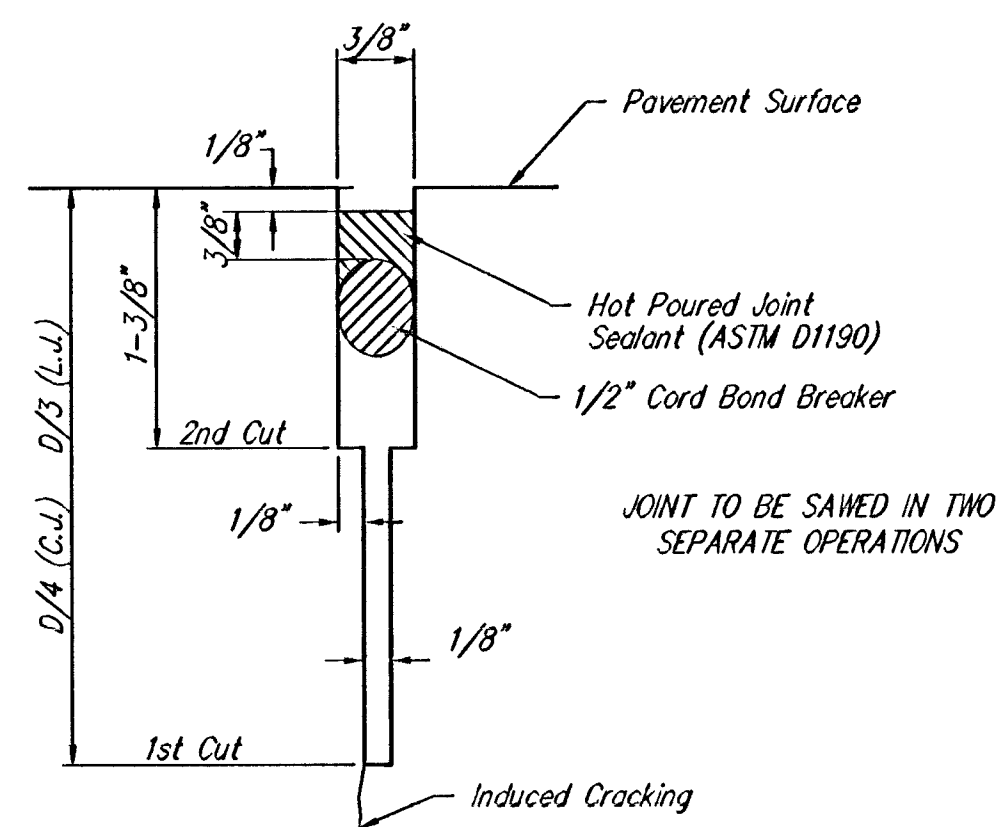

SAW JOINT DETAIL

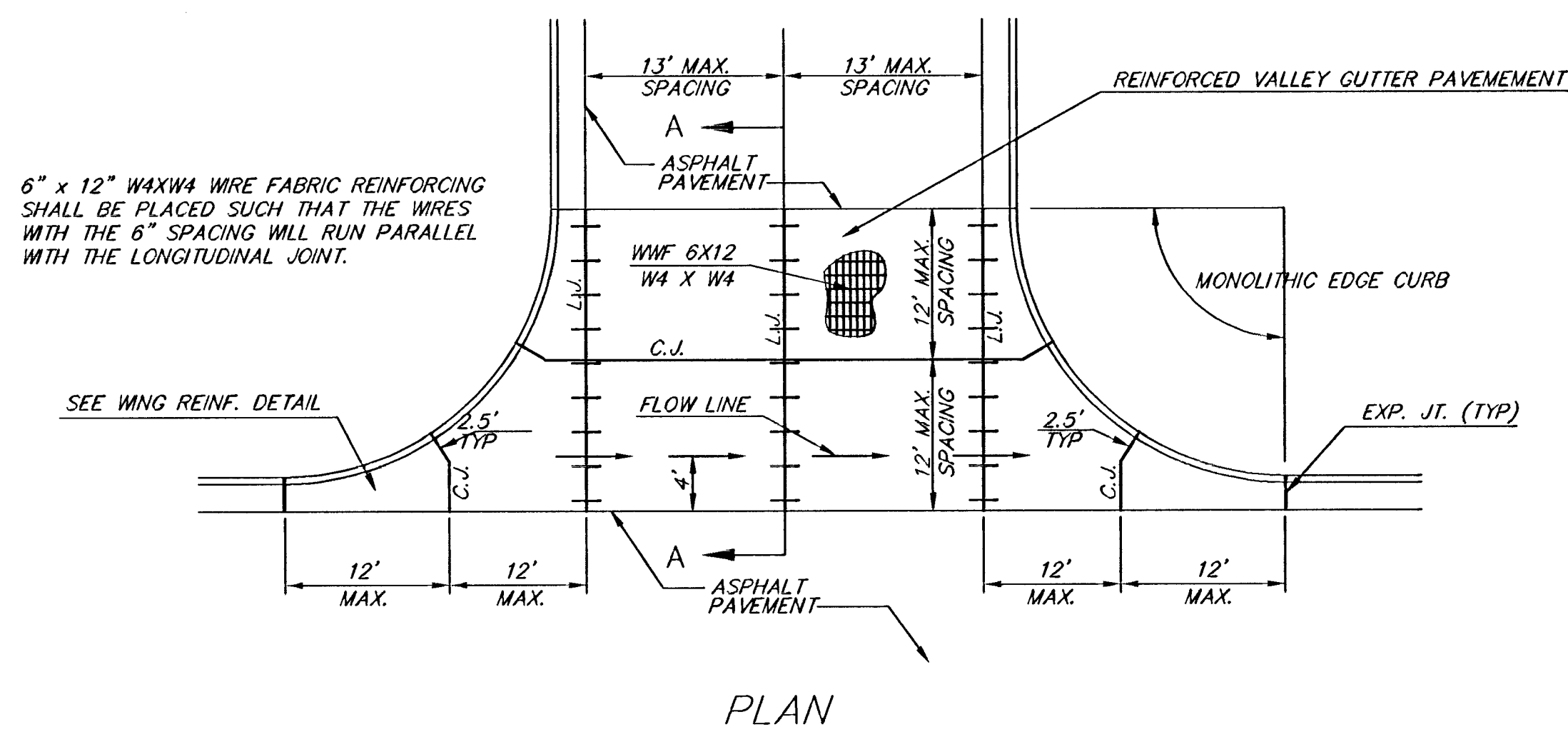

PLAN

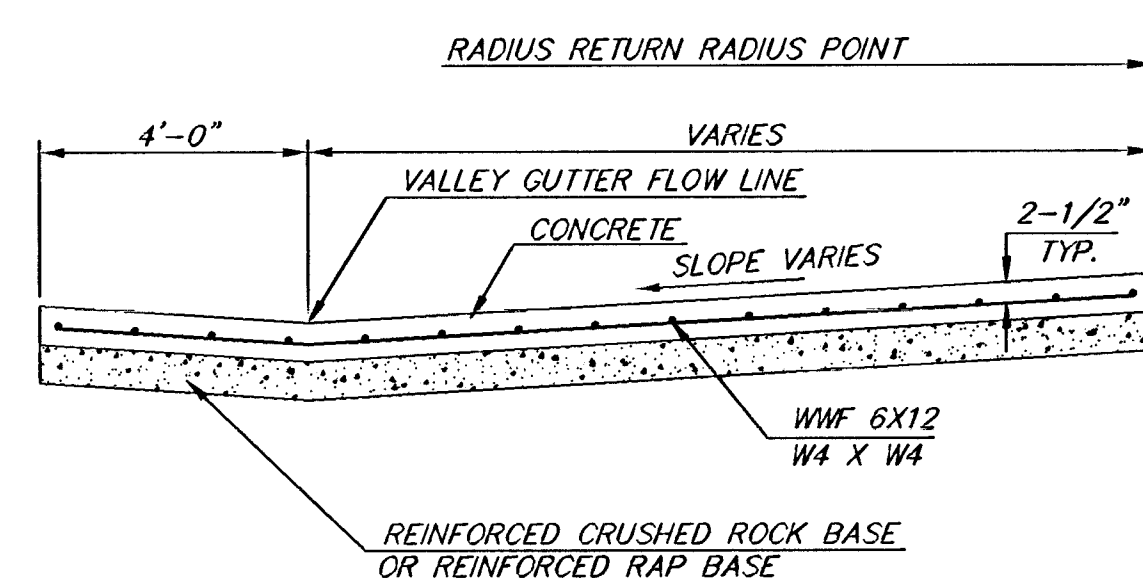

SECTION A-A

REINFORCED VALLEY GUTTER DETAIL

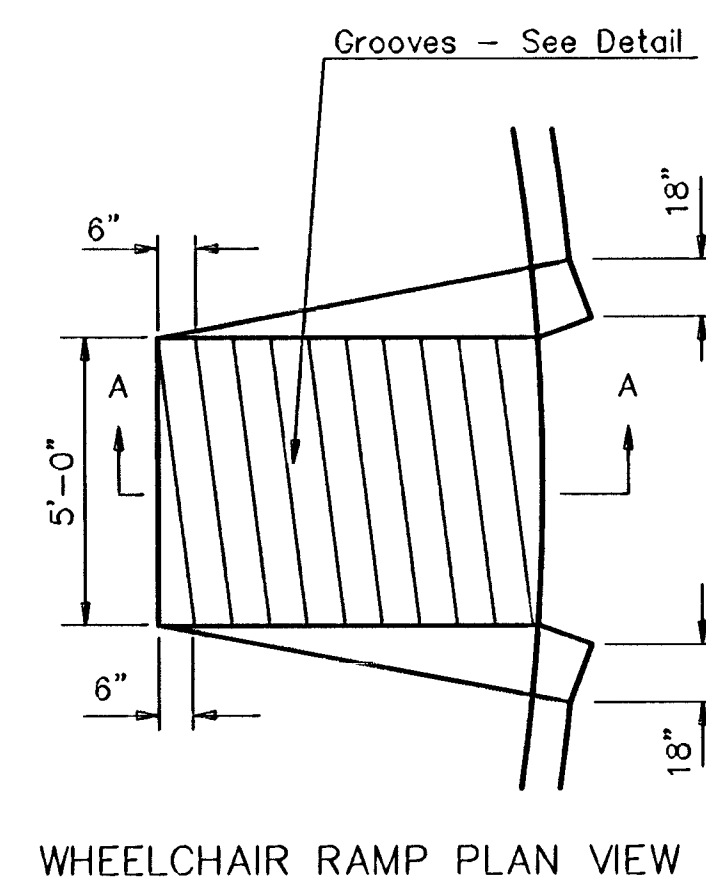

WHEELCHAIR RAMP PLAN VIEW

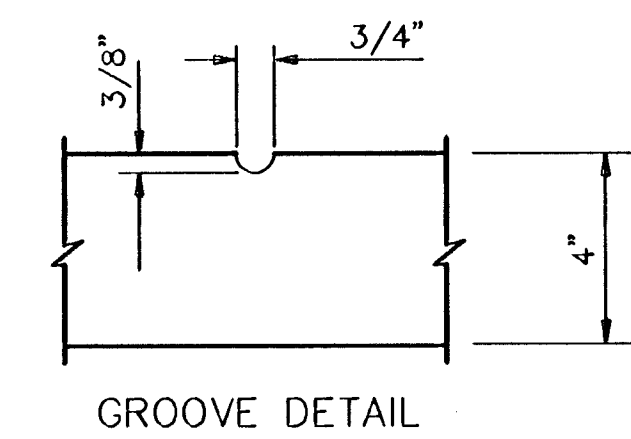

GROOVE DETAIL

WHEELCHAIR RAMP DETAIL

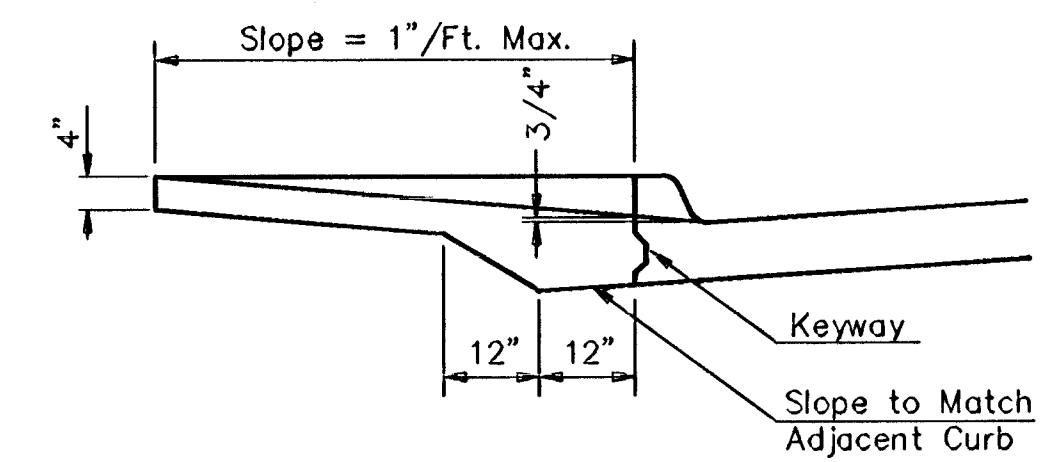

SECTION A-A

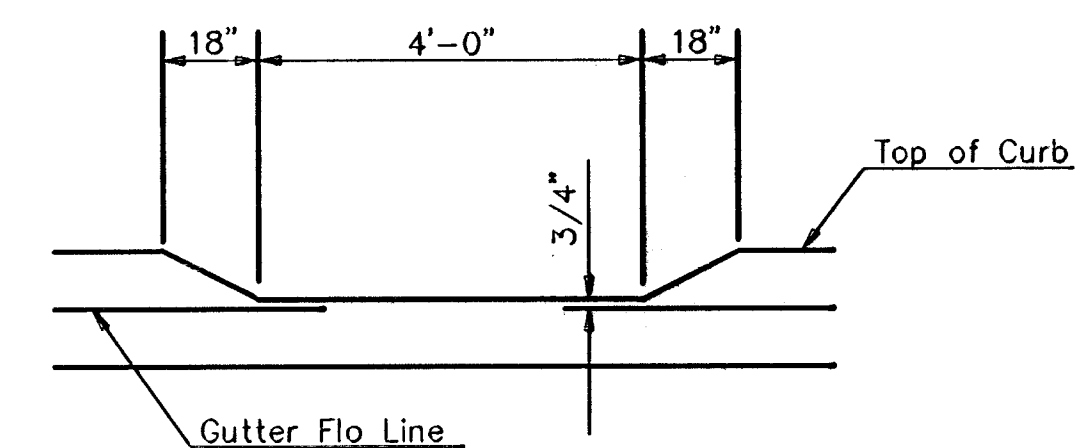

DEPRESSED CURB DETAIL

<p>THE CITY OF WICHITA</p> <p>CITY ENGINEER'S OFFICE CITY HALL - SEVENTH FLOOR 455 NORTH MAIN STREET WICHITA, KANSAS 67202 (316) 268-4001 (316) 268-4114 FAX</p>	VALLEY GUTTER DETAILS	
	WHEELCHAIR RAMP DETAILS	
	M. E. LINDEBAK P.E. - CITY ENGINEER	
	PROJECT NUMBER 472-83448	INDEX CODE 765710
	DATE MAR 96	SHEET 4 OF 35

H:\CIVIL\00062\DWG\00062\00062.BK

H:\CIVIL\00062\DWG\00062\00062.BK