

File: L:\2022\22T41006 - Lionsgate Addition\Drawings\C3DPAVING & SWS\WHEATLAND ST (ENTRANCE).dwg, Last Save: 6/13/2024 2:26 PM Last saved by: MCanereraPiedra
 Last plotted by: Canerera-Piedra, Mainfile Plot Style: --- Plot Scale: 1:2,984.9 Plot Date: 6/20/2024 9:26 AM Plotter used: None

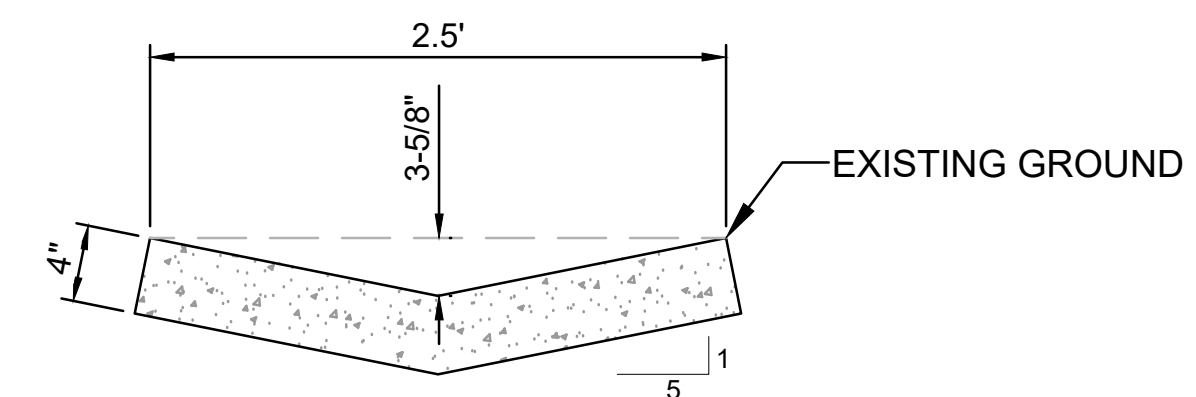

CONCRETE FLUME CROSS-SECTION
 NOT TO SCALE

1. CONCRETE TO BE 3,500-PSI STRENGTH W/ AIR ENTRAINMENT. SUBMIT MIX DESIGN TO ENGINEER FOR APPROVAL.
2. TRANSITION FLOWLINE FROM ROLLED CURB TO FLOWLINE OF FLUME AT FLUME ENTRANCE

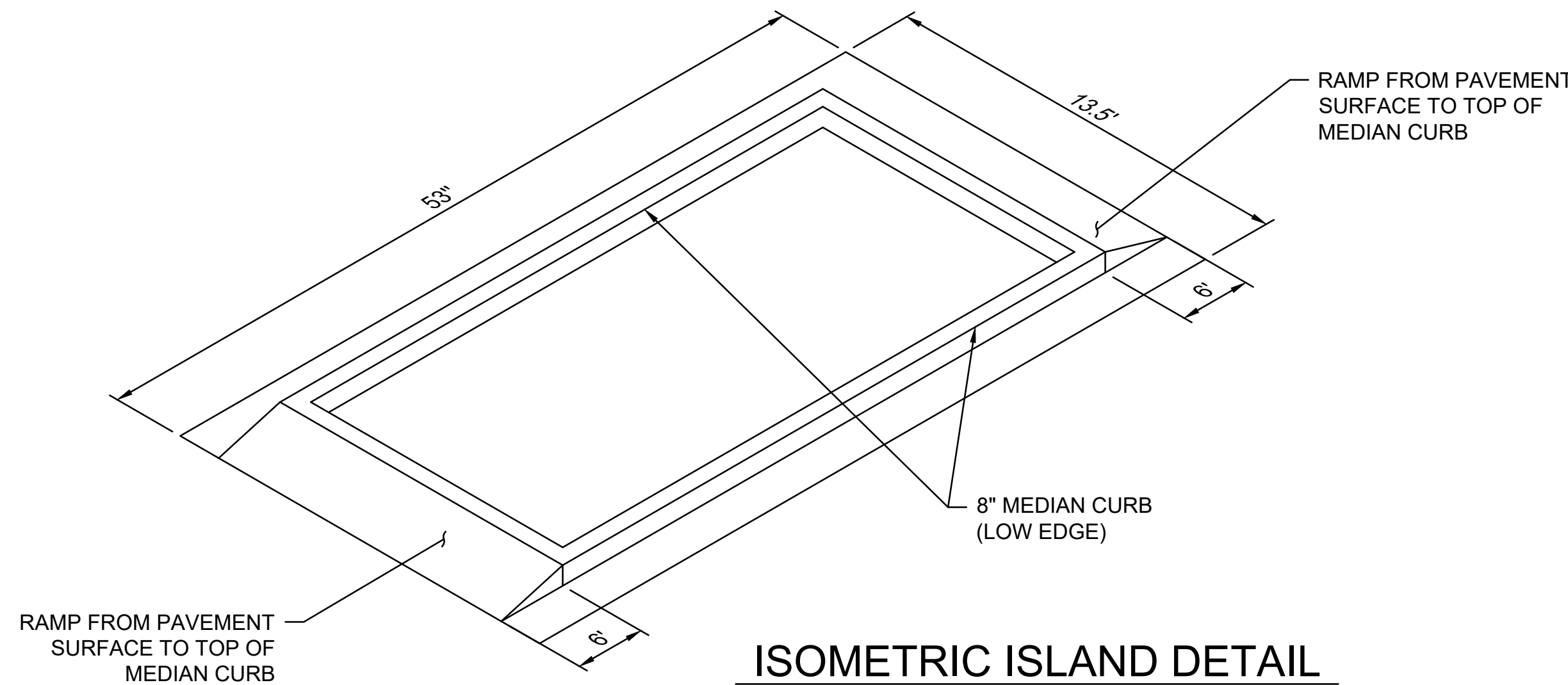
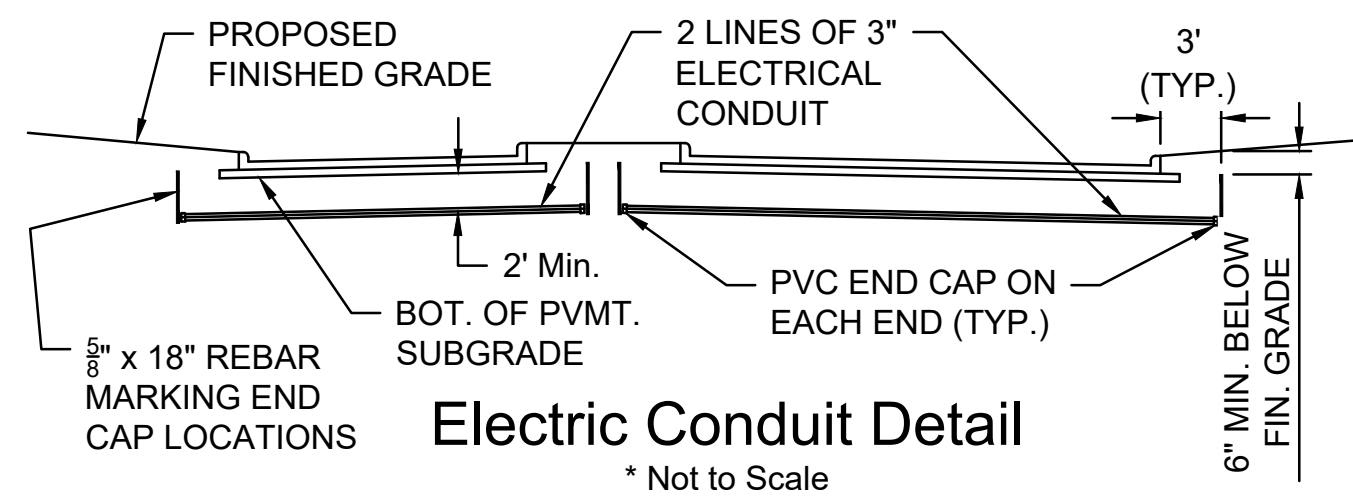
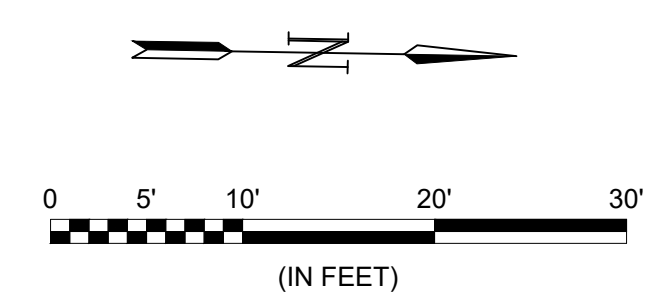
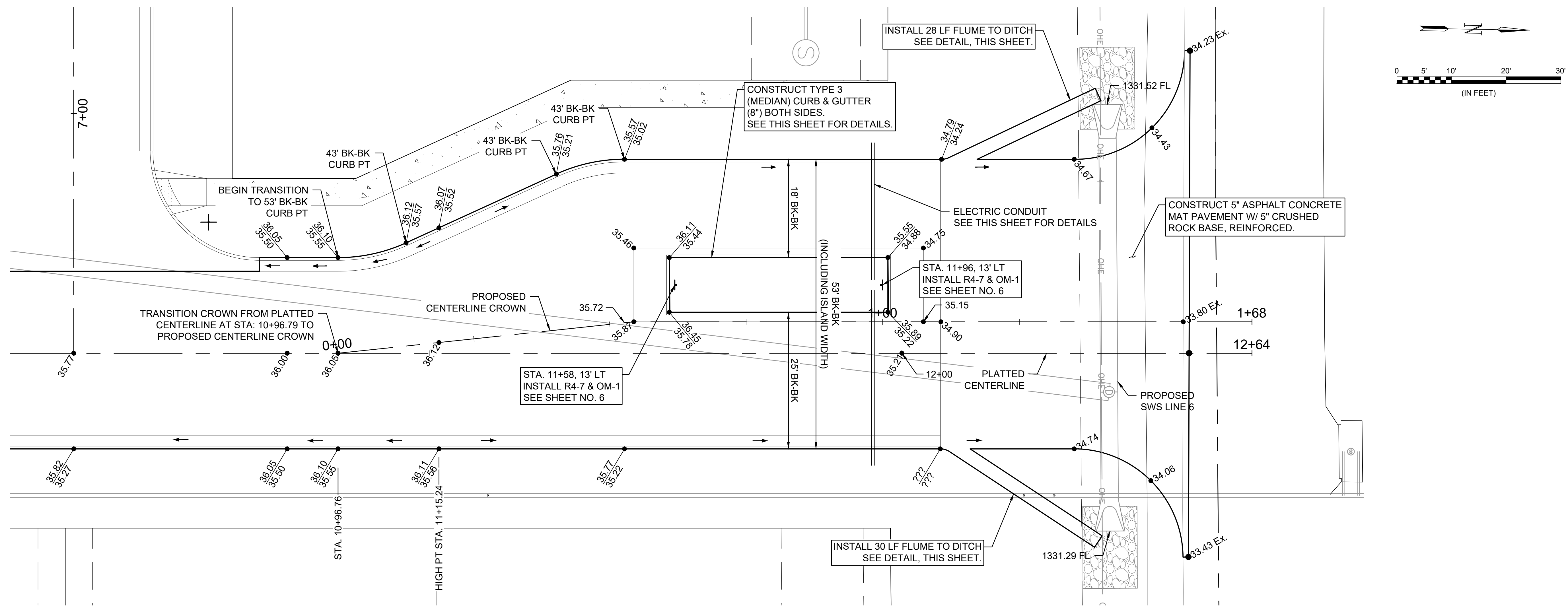

© 2023 GARVER, LLC
 THIS DOCUMENT, ALONG WITH THE IDEAS AND DESIGNS CONVEYED HEREIN, SHALL BE CONSIDERED INSTRUMENTS OF PROFESSIONAL SERVICE AND ARE PROPERTY OF GARVER, LLC. ANY USE, REPRODUCTION, OR DISTRIBUTION OF THIS DOCUMENT, ALONG WITH THE IDEAS AND DESIGN CONTAINED HEREIN, IS PROHIBITED UNLESS AUTHORIZED IN WRITING BY GARVER, LLC OR EXPLICITLY ALLOWED IN THE GOVERNING PROFESSIONAL SERVICES AGREEMENT FOR THIS WORK.

1995 Midfield Road
 Wichita, KS 67209
 (316) 264-8008



REV.	DATE	DESCRIPTION	BY



CITY OF WICHITA
 WICHITA, KANSAS

LIONSGATE
 PAVING & SWS

WHEATLAND ST
 (ENTRANCE)

JOB NO.: 22T41006
 DATE: JUNE 2024
 DESIGNED BY: .
 DRAWN BY: .

BAR IS ONE INCH ON ORIGINAL DRAWING
 IF NOT ONE INCH ON THIS SHEET, ADJUST SCALES ACCORDINGLY.

DRAWING NUMBER

SHEET NUMBER **16** OF **40**