

PLAN VIEW
(N.T.S.)

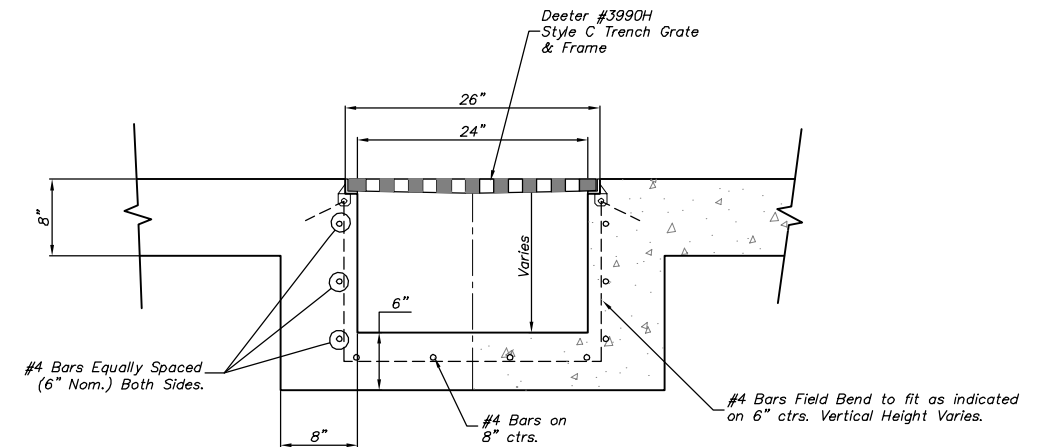

SECTION BB
(N.T.S.)

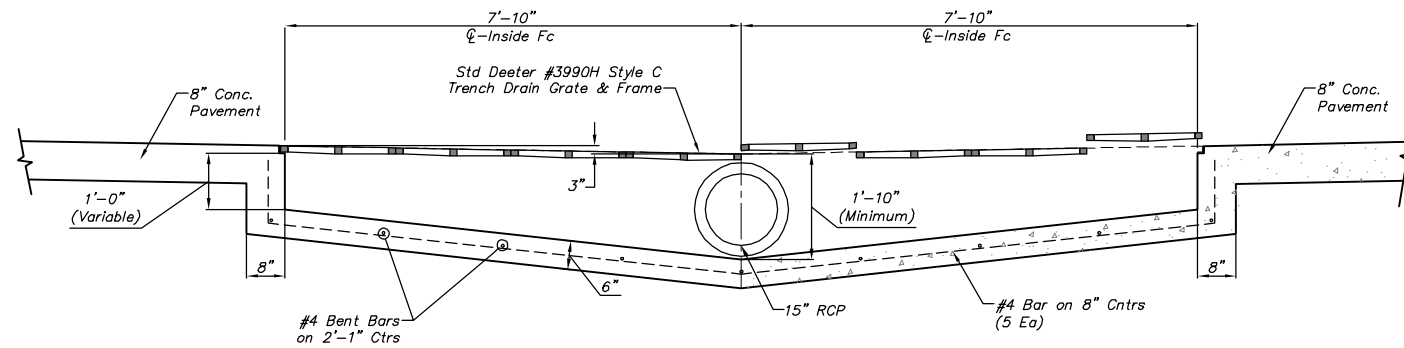

SECTION AA
(N.T.S.)

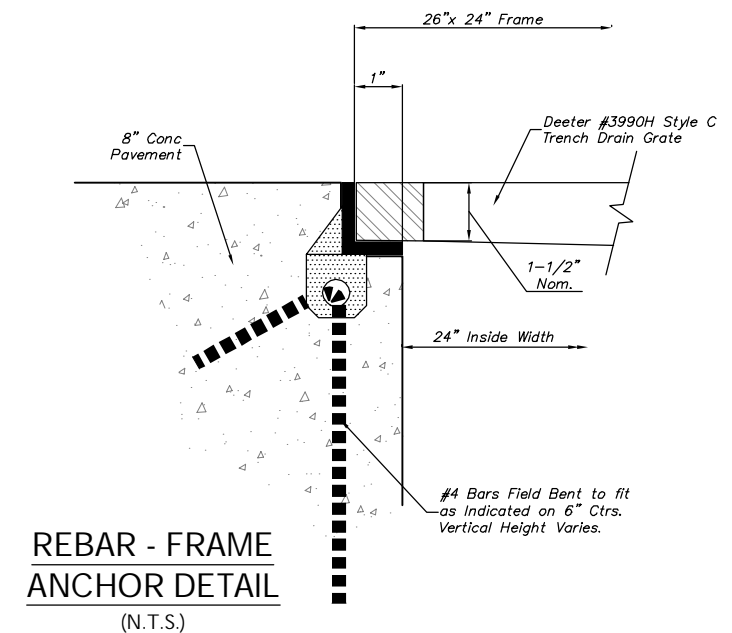

REBAR - FRAME ANCHOR DETAIL
(N.T.S.)