

SEWER AND WATER LINES

THE LOCHS AT ABERDEEN

AN ADDITION TO WICHITA, SEDGWICK COUNTY, KANSAS
 DATE: JAN. 8, 2001

WATER MAINS \$150,500
SEWER LINES \$230,000

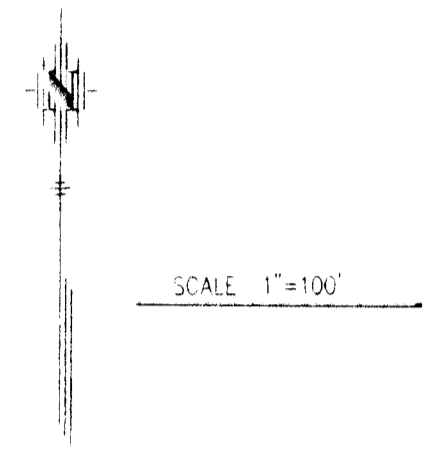

NOTES

1. The Lochs at Aberdeen is a re-plot of Lots 1 through 35, Block 1 and Lots 6 through 23, Block 2 in Aberdeen 3rd Addition.
2. Lots 1 through 20, Block 2 adjoin Reserve B in Aberdeen 3rd Addition. Reserve B is reserved for ponds, drainage and recreation facilities.
3. Lot 45, Block 1 shall become part of the Exchange Assembly of God Addition as provided by a covenant which will be filed with this plat.
4. 24 lots in Block 1 have less than 6000 sq. ft. by a total of 13,684 sq. ft. This area is offset by the 42,088 sq. ft. provided in Reserve A.
5. Reserve A shall permit ponds, drainage, irrigation systems, walks, recreation facilities, parking and utilities confined to easements.
6. A zero side yard setback shall be allowed for Lots 10 through 13, Block 1, Lots 18 through 22, Block 1, Lots 25 through 32, Block 1 and Lots 35 through 43, Block 1 on the common property line having a platted 12 foot setback line.
7. Maintenance for the walls of homes built on a common property line will be provided for by covenant.

BENCHMARKS

- (City of Wichita Datum)
1. City of Wichita Benchmark disc, 67" south of centerline 21st St. & 79" south of section line, and 46" east of centerline 119th St. Elev. 172.98
 2. 80d nail in power pole, 50' east and 50' south of Northwest Corner of Government Lot 6 in SW Quarter of Section 6, T27S, R1W. Elev. 172.08
 3. 80d nail in power pole 50' south of NE corner of Government Lot 3 in NW Quarter of Section 6, T27S, R1W. Elev. 179.98
 4. 80d nail in power pole 40' west and 40' north of the NW Corner of the NW Corner of Sec. 6, T27S, R1W. Elev. 175.05

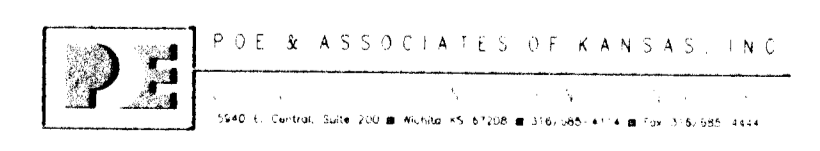

G:\APPS\DATA\PE\BBA\Aberdeen-dist.wfp sewer.dwg Mon Jan 08 14:00:11 2001 Kenny H111, P.E. - Poe & Associates of Kansas