

BRADFORD NORTH

AN ADDITION TO WICHITA, SEDGWICK COUNTY, KANSAS

BENCHMARKS

- City of Wichita Benchmark disc @ Tyler Rd. and 25th St. N. in E. parking of Tyler Rd., 8.3' W. of iron on E. R/W of Tyler Rd., 1' N. of fence corner E. & S. (from Dean Krug C.O.W.) Elev. 165.61
- City of Wichita Benchmark disc @ Tyler Rd. and 29th St. N., 32.3' S. and 30' E. of centerline both, 55.5' E. of PP, 9.2' SE of PP, 44.1' SE of section corner. (from Dean Krug C.O.W.) Elev. 178.04
- "+" cut on N. side of MH ring. Manhole is 13' S and 5' E of NW corner of Lot 23, Block 1, Sterling Farms 2nd Addition. Elev. 169.25
- Top of steel "I" post set 1' below ground 10' N. of center Section 5, T275, R1W Elev. 182.27
- Top of steel "I" post set 6" below ground, 2' E of N-S Fence, 3' E and 24.5' N of W 1/16 Corner of NE Cor. Sect. 5, T275 R1W. Elev. 162.92
- "+" cut on top of conc. headwall at entrance to gas line valve yard, 1160' ± E. of N 1/4 Cor. Sec 5, T275, R1W, on S. side 29th St. N. Elev. 163.45
- RR spike in PP, W side Tyler Rd., on N. side entrance to 2759 N. Tyler Rd. Elev. 175.44

REQUIRED MINIMUM BUILDING ELEVATIONS

DESCRIPTION	MIN. FLOOR ELEV.		MIN. LOW OPENING ELEV.	
	CITY DATUM	M.S.L.	CITY DATUM	M.S.L.
BLOCK 1				
Lots 1-29	163.7	1351.1	163.74	1351.1
Lots 30-36	163.7	1351.1	164.74	1352.1
Lots 37-39	163.7	1351.1	163.74	1351.1
BLOCK 2				
Lots 2-15	163.7	1351.1	167.34	1354.7
Lots 16-26			167.3	1354.7
BLOCK 3				
Lots 1-19			166.5	1353.3
Lots 20-60			166.5	1353.3

No building permits are to be issued for Lots 1 through 39, Block 1 or Lots 2 through 15, Block 2, unless the lowest floor can be constructed above 163.7 City Datum (1351.1 M.S.L.) or unless the City of Wichita has received a letter of map revision from FEMA which will allow buildings to be constructed at the lowest opening listed in the accompanying table.

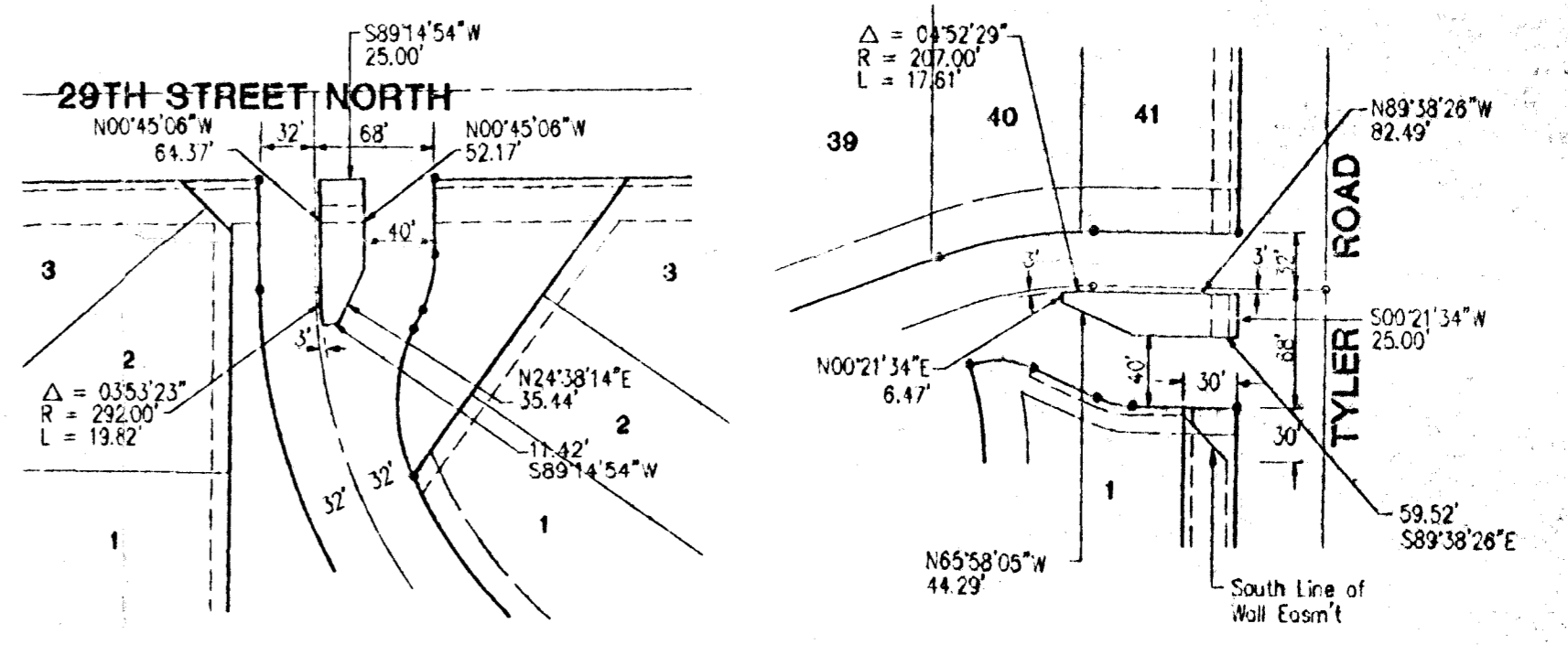

RESERVE B and G DETAILS
NO SCALE.

