



Date 6-19-93 MAB Page 1 of 8
 Project Capital Add.
 Item Drainage Plan

From Sh 1 of 7, Fairfield Estates Drainage Plan, System 500,
 the storm sewer upstream of node 508 is assigned
 to carry $38.6 - 7.1 = 31.5$ cfs. This area has
 been assigned $C = 0.70$ and a 2-yr intensity
 of 4.06 in/hr has been used. (Note, this is from
 old IDF table, current value is 3.83 in/hr).
 Add Lot 2 to 508 as surface flow to street. Check flooded width.

HYDROLOGY

NODE	C	i_2	i_{100}	A	Q_2	Q_{100}
513	0.7	4.06	8.98	0.5	1.4	3.1
509 — Manhole						
Lot 2 (Add to 508)	0.7	4.06	8.98	0.4	1.1	2.5
510	0.7	4.06	8.98	2.2	6.25	13.8
511	0.7	4.06	8.98	3.0	8.5	18.9
512	0.7	4.06	8.98	5.0	14.2	31.4
					<u>31.4</u>	

Add original street flow @ 508 7.1

TOTAL 38.5 check

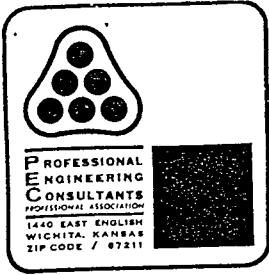

I. DETERMINE INLET SIZES (Base on 2-yr storm)

Node 508	$Q_2 = 38.6$ cfs
Node 507	$Q_2 = 2.4$
Node 506	$Q_2 = 2.0$
Node 504	$Q_2 = 9.1$
Node 503	$Q_2 = 2.4$
Node 502	$Q_2 = 2.8$
Node 501	$Q_2 = 1.2$

As noted on the Drainage Plan, Node 508 drains approx. 13.6 Acres of R-6 Zoning. The Plan stipulates that the street right-of-way is 25' behind the R. is to drain to the street. The remaining portion is to be drained via an internal storm drainage system which is to connect to node 508.

The portion in the street is thus:

$$Q = 0.7 \times 4.06 \times 2.5 \text{ Ac.} = 7.1 \text{ cfs}$$

Using chart 12 attached, use the following:

Use 1 COW Type 1A, L=5', at each node.



Date 6-19-93 MMB Page 3 of 8

Project CAPITAL ADD'N

Item DRAINAGE PLAN

INLET SIZES

INLETS 513 512 511 & 510 TO BE AREA INLETS
 IN SUMP OR CURB INLETS IN SUMP. SELECT
 SIZE USING FHWA HEC-12 CHART 11 & CHART 12
 USE 9" MAX. PONDING

<u>NODE</u>	<u>Q₂</u>	<u>AREA INLET</u>	<u>CURB INLET</u>
510	6.3	P=5' Use 4'x2' (P=12')	5' OPENING d _i =0.62'
511	8.5	P=5' Use 4'x2' (P=12')	5' OPENING d _i =0.60'
512	14.2	P=8' Use 4'x4' (P=16')	10' OPENING d _i =0.58'
513	1.4	P=2' Use 4'x2' P=12'	5' OPENING d _i =0.17'

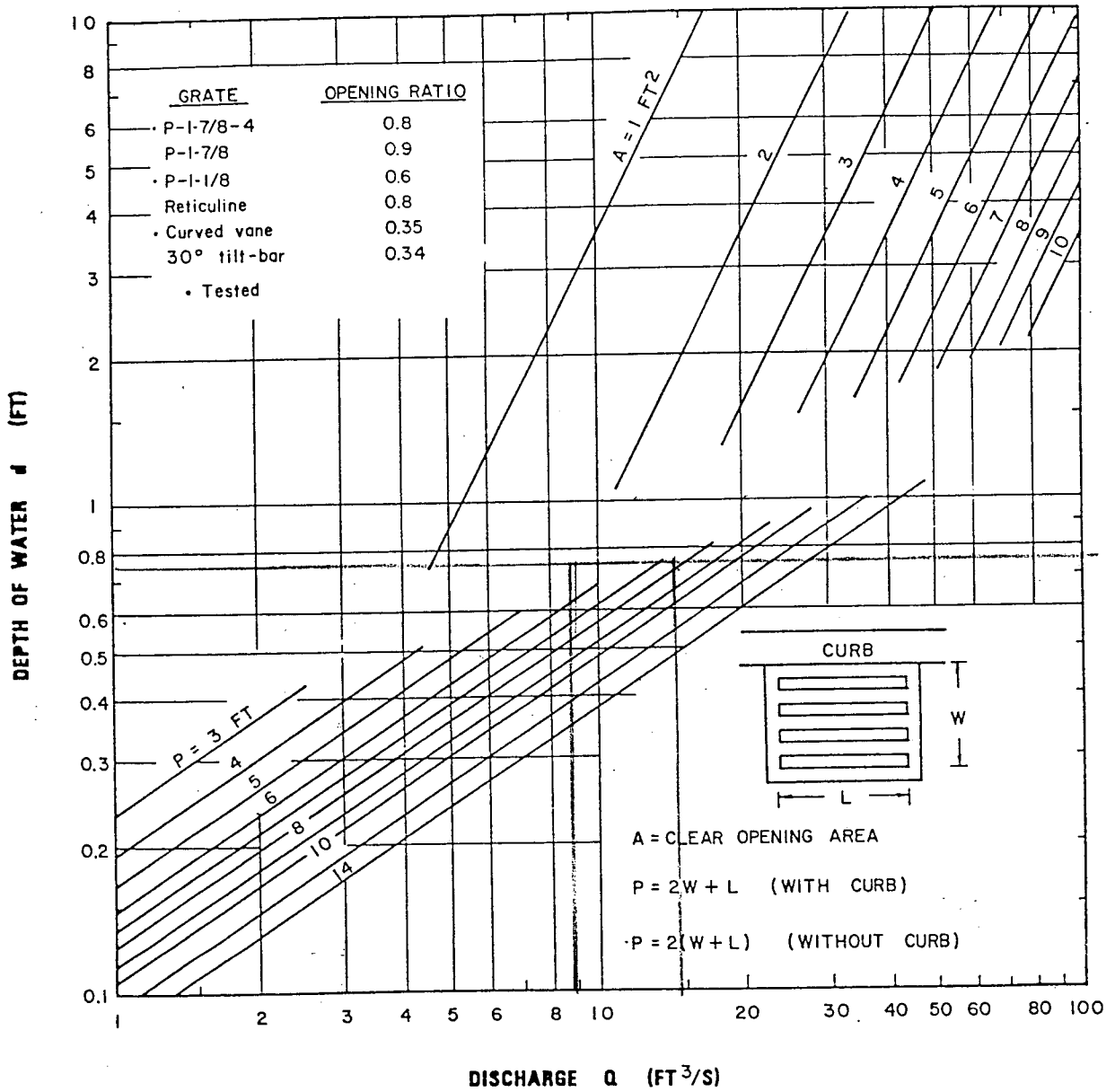
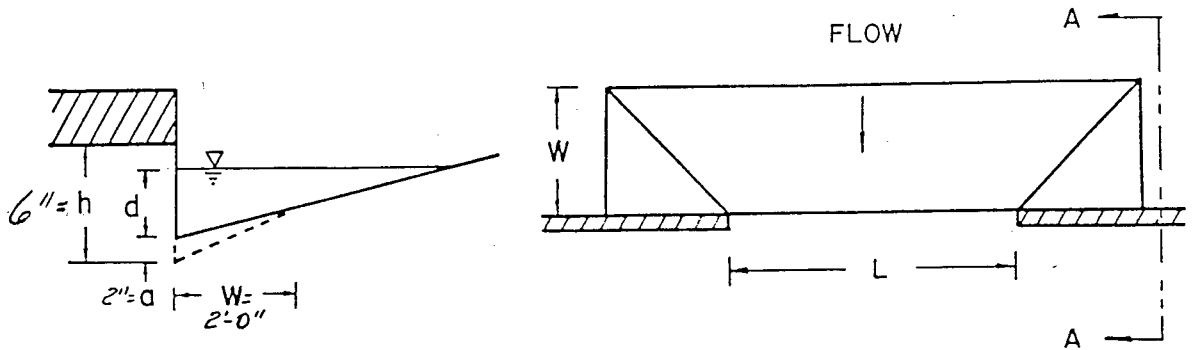

CHART 11. Grate inlet capacity in sump conditions.

FROM: HEC-12, DRAINAGE OF HIGHWAY PAVEMENTS, FHWA, Mar 1984



DEF. SKETCH, C.D.W. TYPE 1A INLET

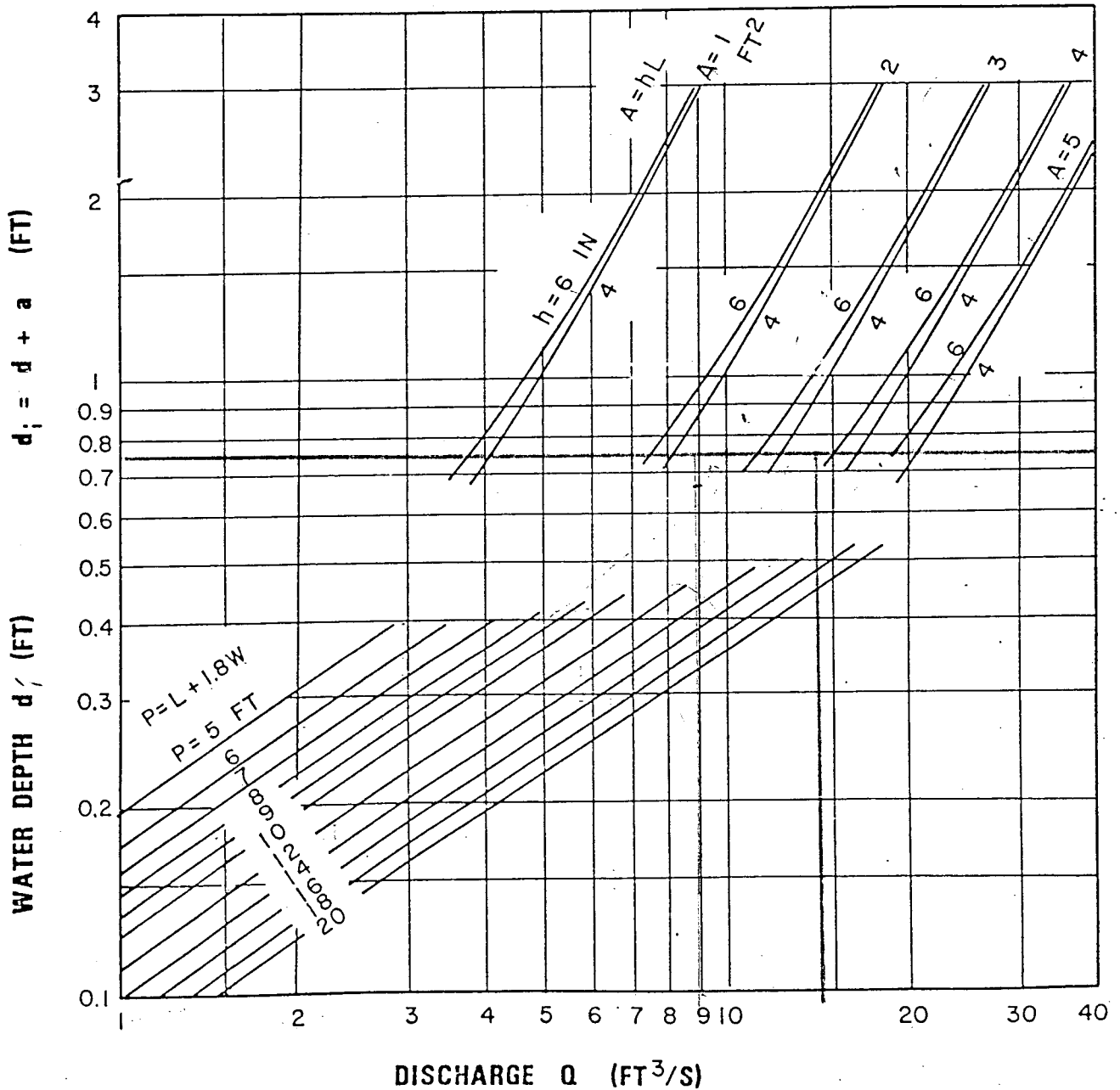

CHART 12. Depressed curb-opening inlet capacity in sump locations.

FROM: HEC-12, DRAINAGE OF HIGHWAY PAVEMENTS, F.H.W.A., MAR., 1984

100 j, 183.8000 508 5 6 5
 110 t, Fairfield Estates 3rd Addition Drainage Plan
 120 t, Storm Sewer System No. 500
 125 t, Note: Use HGL at Node 508 and run upstream.
 130 t, PEC file no 36-93304-2471
 140 t, mwb 6/19/93
 141 i, 513 0.70 00.50 0.00 0.00 01.40 15.00 188.00
 142 i, 512 0.70 05.00 0.00 0.00 14.20 15.00 193.00
 143 i, 511 0.70 03.00 0.00 0.00 08.50 15.00 190.00
 144 i, 510 0.70 02.20 0.00 0.00 06.25 15.00 187.00
 145 m, 509 186.80
 146 m, 508 186.30
 230 p, 513 509 110.00 15 0.013 90.00 0.00
 231 p, 512 511 300.00 24 0.013 00.00 0.00
 232 p, 511 510 300.00 24 0.013 00.00 0.00
 233 p, 510 509 060.00 30 0.013 90.00 0.00
 234 p, 509 508 020.00 30 0.013 90.00 0.00
 320 e

Date: 06-21-1993
Time: 08:55:47

Input File: c:\ffield3.stm

Fairfield Estates 3rd Addition Drainage Plan
Storm Sewer System No. 500
Note: Use EGL at Node 508 and run upstream.
PEC file no 36-93304-2471
mwb 6/19/93

Storm Frequency = 2-Year

* * * H Y D R O L O G Y * * *

***** Tributary Area *****										***** Hydrology Summation *****				***** Conduit Data *****				
Node to Node	C	Area (Ac)	Slope (%)	Length (Ft)	TC(0) (Min)	I(0) (In/Hr)	Q(0) (CFS)	TC (Min)	I (In/Hr)	Q (CFS)	Sum Q (CFS)	Size	Velocity (Ft/Sec)	Length (Ft)	TT (Min)	TT+TC (Min)		
513 509	.70	.50	.00	.0	15.00	3.83	1.40	15.00	3.83	1.40	1.40	15"	1.14	110.00	1.61	16.61		
512 511	.70	5.00	.00	.0	15.00	3.83	14.20	15.00	3.83	14.20	14.20	24"	4.52	300.00	1.11	16.11		
511 510	.70	3.00	.00	.0	15.00	3.83	8.50	16.11	3.71	8.23	22.43	24"	7.14	300.00	.70	16.81		
510 509	.70	2.20	.00	.0	15.00	3.83	6.25	16.81	3.63	5.93	28.36	30"	5.78	60.00	.17	16.98		
509 508	.00	.00	.00	.0	.00	.00	.00	16.98	3.61	.00	29.74	30"	6.06	20.00	.06	17.03		

Date: 06-21-1993
Time: 08:55:47

Input File: c:\ffield3.stm

Fairfield Estates 3rd Addition Drainage Plan
Storm Sewer System No. 500
Note: Use HGL at Node 508 and run upstream.
PEC file no 36-93304-2471
mwb 6/19/93

Storm Frequency = 2-Year

* * * HYDRAULICS * * *

```

*****
Node      Hyd-Slope  Friction  Bend  Transition  Manhole  Deflection  Junction  Total  Hyd-Gl  Desired  Diff.
(Ft/Ft)   (Ft)      (Ft)     (Ft)      (Ft)      (Ft)      (Ft)      (Ft)     (Ft)   Elevation Elevation (Ft)
*****
513      .00047    .0517    .0000    .0000    .0000    .0000    .0000    .0517  184.3501  188.0000  3.65
512      .00394    1.1820    .0000    .0000    .0000    .0000    .0000    1.1820  189.8671  193.0000  3.13
511      .00983    2.9483    .0000    .0474    .0000    .0000    .9843    3.9800  188.6850  190.0000  1.31
510      .00478    .2867    .0000    .0546    .0000    .0000    .0652    .4066  184.7050  187.0000  2.29
509      .00526    .1051    .0000    .0052    .0000    .2591    .1291    .4985  184.2985  186.8000  2.50
508      .00000    .0000    .0000    .0000    .0000    .0000    .0000    .0000  183.8000  186.3000  2.50
*****
    
```

**PROFESSIONAL
ENGINEERING CONSULTANTS, PA**

303 South Topeka
WICHITA, KANSAS 67202

(316) 262-2691

LETTER OF TRANSMITTAL

DATE	6/19/93	JOB NO.	36-93304-2471
ATTENTION:	Vicky R. Huang, P.E.		
RE:	CAPITAL ADDN. Drainage Plan		

TO City Engineer's Office
7th Floor City Hall
Wichita, KS 67202

WE ARE SENDING YOU Attached Under separate cover via _____ the following items:

- Shop drawings Prints Plans Samples Specifications
 Copy of letter Change order _____

COPIES	DATE	NO.	DESCRIPTION
2	6/21/93		Computations (8 sheets)
2	6/21/93		Drainage Plan

THESE ARE TRANSMITTED as checked below:

- For approval Approved as submitted Resubmit _____ copies for approval
 For your use Approved as noted Submit _____ copies for distribution
 As requested Returned for corrections Return _____ corrected prints
 For review and comment _____
 FOR BIDS DUE _____ 19 _____ PRINTS RETURNED AFTER LOAN TO US

REMARKS _____

COPY TO FILE

SIGNED: Michael W. Berry, P.E.

Date 11-5-85 Page 1 of 7Project Fairfield EstatesItem Storm Sewer System 500

I. DETERMINE INLET SIZES (Base on 2-yr storm)

Node 508 $Q_2 = 38.6$ cfsNode 507 $Q_2 = 2.4$ Node 506 $Q_2 = 2.0$ Node 504 $Q_2 = 9.1$ Node 503 $Q_2 = 2.4$ Node 502 $Q_2 = 2.8$ Node 501 $Q_2 = 1.2$

As noted on the Drainage Plan, Node 508 drains approx. 13.6 Acres of R-6 Zoning. The Plan stipulates that the street right-of-way & 25' behind the R is to drain to the street. The remaining portion is to be drained via an internal storm drainage system which is to connect to node 508.

The portion in the street is thus:

$$Q = 0.7 \times 4.06 \times 2.5 \text{ Ac.} = 7.1 \text{ cfs}$$

Using chart 12 attached, use the following:

Use 1 COW Type 1A, $L=5'$, at each node.



Date 6-19-93 MMB Page 3 of 8

Project CAPITAL ADD'N

Item DRAINAGE PLAN

INLET SIZES

INLETS 513 512 511 & 510 TO BE AREA INLETS
 IN SUMP OR CURB INLETS IN SUMP. SELECT
 SIZE USING FHWA HEC-12 CHART II & CHART 12
 USE 9" MAX. PONDING

<u>NODE</u>	<u>Q2</u>	AREA INLET	CURB INLET
510	6.3	P=5' Use 4'x2' (P=12')	5' OPENING $d_i = 0.62'$
511	8.5	P=5' Use 4'x2' (P=12')	5' OPENING $d_i = 0.60'$
512	14.2	P=8' Use 4'x4' (P=16')	10' OPENING $d_i = 0.58'$
513	1.4	P=2' Use 4'x2' P=12'	5' OPENING $d_i = 0.17'$

4/8

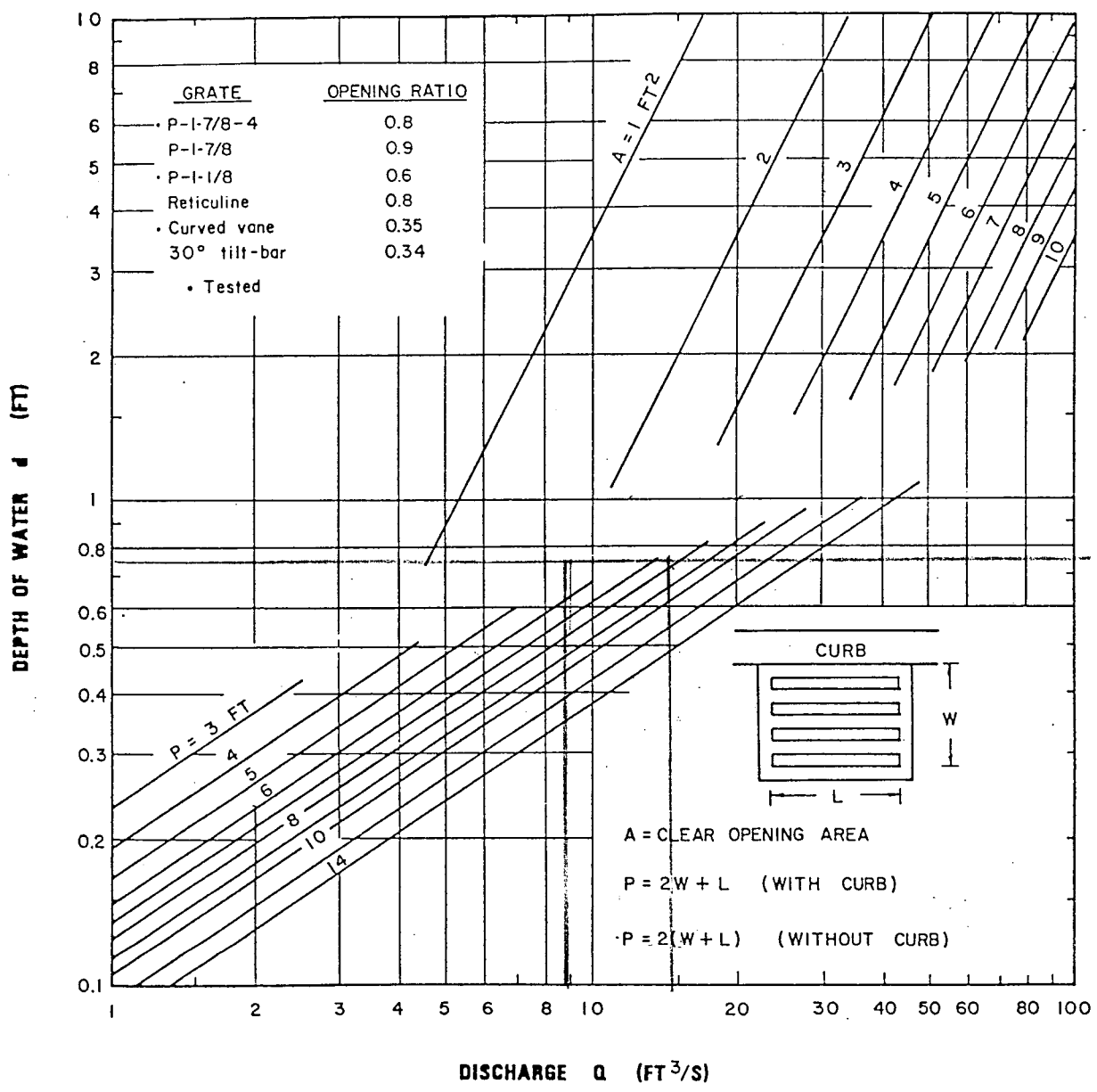
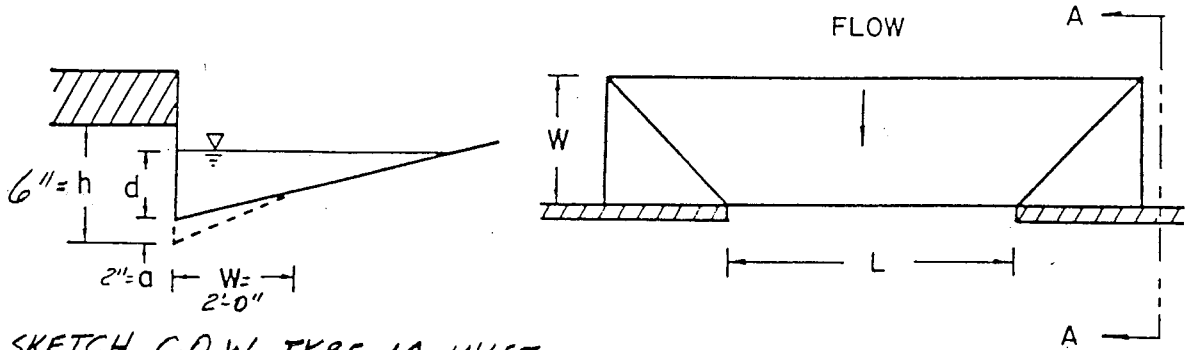

CHART 11. Grate inlet capacity in sump conditions.

FROM: HEC-12, DRAINAGE OF HIGHWAY PAVEMENTS, FHWA, May 1984



DEF. SKETCH, C.D.W. TYPE 1A INLET

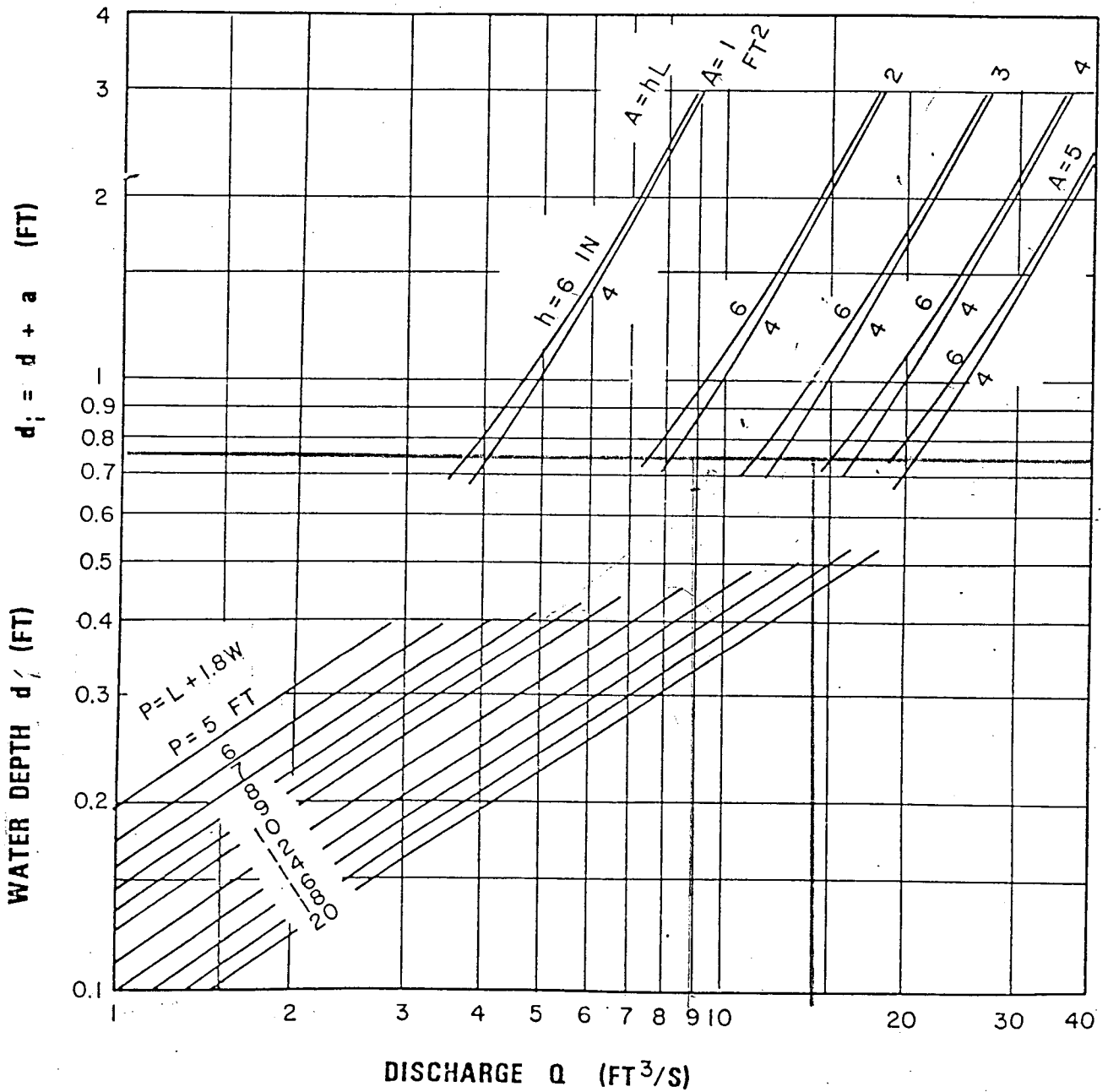

CHART 12. Depressed curb-opening inlet capacity in sump locations.

FROM: HEC-12, DRAINAGE OF HIGHWAY PAVEMENTS, F.H.W.A., MAR, 1984

100 j, 183.8000 508 5 6 5
110 t, Fairfield Estates 3rd Addition Drainage Plan
120 t, Storm Sewer System No. 500
125 t, Note: Use HGL at Node 508 and run upstream.
130 t, PEC file no 36-93304-2471
140 t, mwb 6/19/93
141 i, 513 0.70 00.50 0.00 0.00 01.40 15.00 188.00
142 i, 512 0.70 05.00 0.00 0.00 14.20 15.00 193.00
143 i, 511 0.70 03.00 0.00 0.00 08.50 15.00 190.00
144 i, 510 0.70 02.20 0.00 0.00 06.25 15.00 187.00
145 m, 509 186.80
146 m, 508 186.30
230 p, 513 509 110.00 15 0.013 90.00 0.00
231 p, 512 511 300.00 24 0.013 00.00 0.00
232 p, 511 510 300.00 24 0.013 00.00 0.00
233 p, 510 509 060.00 30 0.013 90.00 0.00
234 p, 509 508 020.00 30 0.013 90.00 0.00
320 e

Date: 06-21-1993
Time: 08:55:47

Input File: c:\ffield3.stm

Fairfield Estates 3rd Addition Drainage Plan
Storm Sewer System No. 500
Note: Use BGL at Node 508 and run upstream.
PEC file no 36-93304-2471
mwb 6/19/93

Storm Frequency = 2-Year

* * * HYDROLOGY * * *

Tributary Area				Hydrology Summation				Conduit Data									

Node to	C	Area	Slope	Length	TC(0)	I(0)	Q(0)	TC	I	Q	Sum Q	Size	Velocity	Length	TT	TT+TC	
Node		(Ac)	(%)	(Ft)	(Min)	(In/Hr)	(CFS)	(Min)	(In/Hr)	(CFS)	(CFS)		(Ft/Sec)	(Ft)	(Min)	(Min)	

513	509	.70	.50	.00	.0	15.00	3.83	1.40	15.00	3.83	1.40	1.40	15"	1.14	110.00	1.61	16.61
512	511	.70	5.00	.00	.0	15.00	3.83	14.20	15.00	3.83	14.20	14.20	24"	4.52	300.00	1.11	16.11
511	510	.70	3.00	.00	.0	15.00	3.83	8.50	16.11	3.71	8.23	22.43	24"	7.14	300.00	.70	16.81
510	509	.70	2.20	.00	.0	15.00	3.83	6.25	16.81	3.63	5.93	28.36	30"	5.78	60.00	.17	16.98
509	508	.00	.00	.00	.0	.00	.00	.00	16.98	3.61	.00	29.74	30"	6.06	20.00	.06	17.03

Date: 06-21-1993
Time: 08:55:47

Input File: c:\ffield3.stm

Fairfield Estates 3rd Addition Drainage Plan
Storm Sewer System No. 500
Note: Use HGL at Node 508 and run upstream.
PEC file no 36-93304-2471
mwb 6/19/93

Storm Frequency = 2-Year

* * * HYDRAULICS * * *

```

*****
Node      Hyd-Slope  Friction  Bend  Transition  Manhole  Deflection  Junction  Total  Hyd-Gl  Desired  Diff.
(Ft/Ft)   (Ft)      (Ft)     (Ft)     (Ft)        (Ft)      (Ft)       (Ft)     (Ft)   Elevation Elevation (Ft)
*****
513      .00047    .0517    .0000   .0000       .0000     .0000      .0000    .0517  184.3501  188.0000  3.65
512      .00394    1.1820   .0000   .0000       .0000     .0000      .0000    1.1820  189.8671  193.0000  3.13
511      .00983    2.9483   .0000   .0474       .0000     .0000      .9843    3.9800  188.6850  190.0000  1.31
510      .00478    .2867    .0000   .0546       .0000     .0000      .0652    .4066  184.7050  187.0000  2.29
509      .00526    .1051    .0000   .0052       .0000     .2591      .1291    .4985  184.2985  186.8000  2.50
508      .00000    .0000    .0000   .0000       .0000     .0000      .0000    .0000  183.8000  186.3000  2.50
*****
    
```