

**PROFESSIONAL  
ENGINEERING CONSULTANTS, PA**

1440 E. English  
WICHITA, KANSAS 67211

(316) 262-2691

TO Michael E. Lindebak, P.E.  
City Engineer  
455 North Main  
Wichita, KS 67207

**LETTER OF TRANSMITTAL**

DATE	July 8, 1988	JOB NO.	36-87468-2027
ATTENTION	Ms. Vicky Huang, P.E.		
RE:	Emery Park Addition		

WE ARE SENDING YOU  Attached  Under separate cover via \_\_\_\_\_ the following items:

- Shop drawings     Prints     Plans     Samples     Specifications  
 Copy of letter     Change order     \_\_\_\_\_

COPIES	DATE	NO.	DESCRIPTION
2	July 15, 1988		"Drainage Plan and Supporting Calculations"

THESE ARE TRANSMITTED as checked below:

- For approval     Approved as submitted     Resubmit \_\_\_\_\_ copies for approval  
 For your use     Approved as noted     Submit \_\_\_\_\_ copies for distribution  
 As requested     Returned for corrections     Return \_\_\_\_\_ corrected prints  
 For review and comment     \_\_\_\_\_  
 FOR BIDS DUE \_\_\_\_\_ 19 \_\_\_\_\_  PRINTS RETURNED AFTER LOAN TO US

REMARKS The Final Plat will be submitted on July 15, 1988 for  
hearing by the Subdivision Committee on July 28, 1988.

COPY TO T. Shabshab

SIGNED: Charles S. Brown

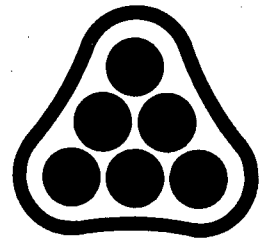

**P**ROFESSIONAL  
**E**NGINEERING  
**C**ONSULTANTS  
PROFESSIONAL ASSOCIATION

DRAINAGE PLAN  
AND  
SUPPORTING CALCULATIONS

FOR  
EMERY PARK ADDITION  
TO WICHITA, SEDGWICK COUNTY, KANSAS

PREPARED BY  
PROFESSIONAL ENGINEERING CONSULTANTS, P.A.  
ENGINEERS  
WICHITA, KANSAS

JULY 15, 1988



Date July 1, 1988 Page 1 of 7

Project Emery Park Add.

Item Drainage SYSTEM 100

I HYDROLOGY Use Rational Method  $Q = CIA$

Determine "C"

<u>Node</u>	<u>Land Use</u>	<u>Hyd. Soil Group</u>	<u>C<sub>2</sub></u>	<u>C<sub>100</sub></u>
102	Res. 1/4 Ac.	B	0.44	0.61
101	Res. 1/4 Ac.	B	0.44	0.61
100	(End section)			

Determine "I"

<u>Node</u>	<u>t<sub>c</sub></u>	<u>I<sub>2</sub></u>	<u>I<sub>100</sub></u>
102	15	3.83	7.37
101	15	3.83	7.37
100	(End section)		

Determine "A"

<u>Node</u>	<u>Plan. Units</u>	<u>Area - SF</u>	<u>Area - Ac.</u>
102	1304	210,240	5.0
101	1361	217,760	5.0
100	(End section)		



Date July 1, 1988 Page 2 of 7

Project Emery Park Add.

Item Drainage SYSTEM 100

Determine "Q<sub>2</sub>"

<u>Node</u>	<u>C<sub>2</sub></u>	<u>I<sub>2</sub></u>	<u>A</u>	<u>Q<sub>2</sub></u>
102	0.44	3.83	5.0	8.4
101	0.44	3.83	5.0	8.4
100	(End Section)			

Determine "Q<sub>100</sub>"

<u>Node</u>	<u>C<sub>100</sub></u>	<u>I<sub>100</sub></u>	<u>A</u>	<u>Q<sub>100</sub></u>
102	0.61	7.37	5.0	22.5
101	0.61	7.37	5.0	22.5
100	(End Section)			



Date July 1, 1988 Page 3 of 7

Project Emery Park Add

Item Drainage - SYSTEM 100

II INLET SIZING / FLOOD ROUTING (100-Yr)

<u>Node</u>	<u>Inlet Condition</u>	<u>Q<sub>100</sub></u>	<u>Inlet L</u>	<u>Q<sub>max</sub>*</u>	<u>Q<sub>intercept</sub>†</u>	<u>Q<sub>bypass</sub></u>	<u>to Node #</u>
102	Sump	22.5	10'	27.0	22.5	0.0	-
101	Sump	22.5	10'	27.0	22.5	0.0	-
100	(End Section)						

\* See Chart 12 † Input for "Storm" Program.

III STREET FLOW (2-YR)

<u>Node</u>	<u>Q<sub>e</sub></u>	<u>Distribution</u>	<u>street slope</u>	<u>d</u>	<u>d<sub>max</sub></u>	<u>Comment</u>
102	8.4	50% (W) = 4.2	0.32%	0.37'	0.55'	OK
		50% (S) = 4.2	0.32%	0.37'	0.55'	OK
101	8.4	50% (W) = 4.2	0.32%	0.37'	0.55'	OK
		50% (S) = 4.2	0.32%	0.37'	0.55'	OK
100	(End Section)					

IV STREET FLOW (100-YR)

<u>Location</u>	<u>Contributing Areas</u>	<u>Q<sub>100</sub></u>	<u>Q<sub>pipe</sub></u>	<u>Q<sub>street</sub></u>	<u>street slope</u>	<u>Q<sub>max</sub>**</u>	<u>Comment</u>
Approaching Nodes 102 & 101 From W.	50% 102 =	11.3	0.0	22.5	0.32%	43.7	OK std cb 0.3' wk gr.
	50% 101 =	11.2					
Approaching Nodes 102 & 101 From S.	50% 102 =	11.2	0.0	22.5	0.32%	43.7	OK std cb 0.3' wk gr.
	50% 101 =	11.3					
		22.5					

\*\* See page 4



Date 1.1.88 Page 4 of 7

Project Emery Park Add.

Item Drainage

Determine Capacities of Standard Curb Streets w/  
Various Walk Grades for 100-year storm analysis  
(58' R-O-W)

0.3' WALK GRADE

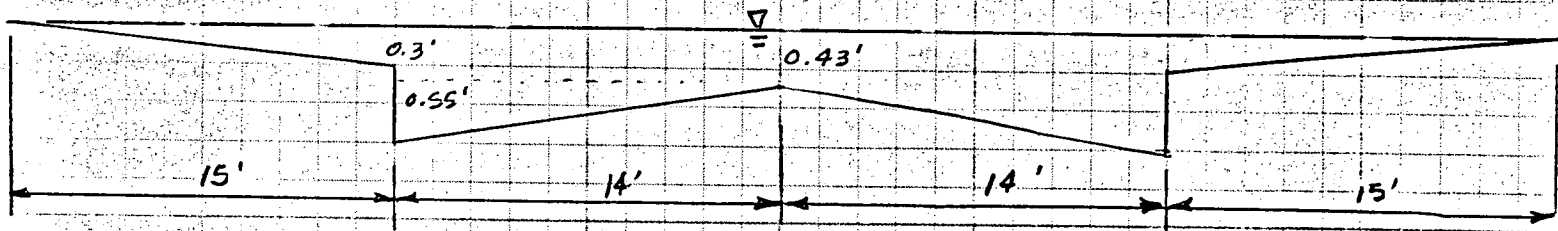

$$n = \frac{(2 \times 14.5 \times 0.03) + (2 \times 3.05 \times 0.013) + (2 \times 12 \times 0.016)}{59.1}$$

$$= \frac{(0.87) + (0.0793) + (0.384)}{59.1} = \frac{1.3333}{59.1} = 0.0226$$

$$A = (2 \times \frac{1}{2} \times 15 \times 0.3) + (28 \times 0.43) + (2 \times \frac{1}{2} \times 14 \times 0.42)$$

$$= (4.5) + (12.04) + (5.88)$$

$$= 22.42$$

$$p = 59.1$$

$$R = A/p = 22.42/59.1 = 0.379357$$

$$R^{2/3} = 0.52404$$

$$Q = \frac{1.486}{n} A R^{2/3} S^{1/2}$$

$$Q = \frac{1.486}{0.0226} \times 22.42 \times 0.52404 \times S^{1/2}$$

$$Q = 772.5 \sqrt{S}$$

100 j,	84.7000	100	3	3	2			
110 t,	emery park addition							
120 t,	drainage plan							
130 t,	system 100 analysis							
140 i,	102	0.61	5.00	0.00	0.00	22.50	15.00	87.10
150 i,	101	0.61	5.00	0.00	0.00	22.50	15.00	87.10
160 m,	100	84.70						
170 p,	102	101	35.00	24	0.013	0.00	0.00	
180 p,	101	100	200.00	36	0.013	0.00	0.00	
190 e								

Input File: emery100

emery park addition  
drainage plan  
system 100 analysis

Storm Frequency = 100-Year

\*\*\* HYDRAULICS \*\*\*

```

*****
Node      Hyd-Slope  Friction  Bend  Transition  Manhole  Deflection  Junction  Total  Hyd-61  Desired*  Diff. †
(Ft/Ft)   (Ft)      (Ft)    (Ft)    (Ft)        (Ft)      (Ft)       (Ft)    (Ft)    Elevation  Elevation  (Ft)
*****
102      0.00989   0.3462   0.0000  0.0000     0.0000    0.0000    0.0000    0.3462  86.7847  87.1000   0.32
101      0.00454   0.9085   0.0000  0.0337     0.0000    0.0000    0.7963    1.7384  86.4384  87.1000   0.66
100      0.00000   0.0000   0.0000  0.0000     0.0000    0.0000    0.0000    0.0000  84.7000  84.7000   0.00
*****

```

\* Top Curb.  
† For 100-yr, HGL  
could be 0.3' above  
Top Curb

7/7

Date: 07-07-1988  
Time: 10:06:29

Input File: emery100

emery park addition  
drainage plan  
system 100 analysis

Storm Frequency = 100-Year

\*\*\* HYDROLOGY \*\*\*

Tributary Area										Hydrology Summation			Conduit Data				
Node to Node	C	Area (Ac)	Slope (%)	Length (Ft)	TC(θ) (Min)	I(θ) (In/Hr)	Q(θ) (CFS)	TC (Min)	I (In/Hr)	Q (CFS)	Sum Q (CFS)	Size	Velocity (Ft/Sec)	Length (Ft)	TT (Min)	TT+TC (Min)	
102	101	0.61	5.00	0.00	0.0	15.00	8.97	22.50	15.00	8.97	22.50	22.50	24"	7.16	35.00	0.08	15.08
101	100	0.61	5.00	0.00	0.0	15.00	8.97	22.50	15.00	8.95	22.45	44.95	36"	6.36	200.00	0.52	15.61



Date July 1, 1988 Page 1 of 8

Project Emery Park Addition

Item Drainage System 200

I. HYDROLOGY

Use Rational Method

$Q = CIA$

Determine "c"

<u>Node</u>	<u>Land Use</u>	<u>Hyd. Soil Group</u>	<u>C<sub>2</sub></u>	<u>C<sub>100</sub></u>
204	Light Indust.	B	0.68	0.80
203	50% Light Comm. 50% Light Ind.	B	0.68	0.80
202	(Manhole)			
201	(End Section)			

Determine "I"

<u>Node</u>	<u>t<sub>c</sub></u>	<u>I<sub>5</sub></u>	<u>I<sub>100</sub></u>
204	15	4.56	7.37
203	15	4.56	7.37
202	(Manhole)		
201	(End Section)		



Date July 1, 1988 Page 2 of 8

Project Emery Park Addition

Item Drainage System 200

Determine "A"

<u>Node</u>	<u>Plan. Units</u>	<u>Area - S.F.</u>	<u>Area - Ac.</u>
204	1030	164,800	3.8
203	960	153,600	3.5
202	(Manhole)		
201	(End Section)		

Determine "Q<sub>s</sub>"

<u>Node</u>	<u>C<sub>s</sub></u>	<u>I<sub>s</sub></u>	<u>A</u>	<u>Q<sub>s</sub></u>
204	0.68	4.56	3.8	11.8
203	0.68	4.56	3.5	10.9
202	(Manhole)			
201	(End Section)			



Date July 1, 1988 Page 3 of 8

Project Emery Park Add.

Item Drainage System 200

Determine "Q<sub>100</sub>"

<u>Node</u>	<u>C<sub>100</sub></u>	<u>I<sub>100</sub></u>	<u>A</u>	<u>Q<sub>100</sub></u>
204	0.80	737	3.8	22.4
203	0.80	737	3.5	20.6
202	(Manhole)			
201	(End Section)			

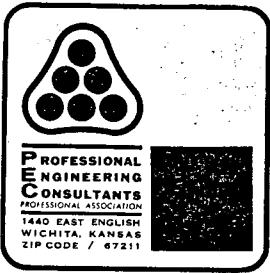

Date July 1, 1988 Page 4 of 8

Project Emery Park Addition

Item Drainage System 200

II INLET SIZING / FLOOD ROUTING (100-yr)

Node	Inlet Condition	Q <sub>100</sub>	Inlet L	Q <sub>max</sub> *	Q <sub>intercept</sub> †	Q <sub>bypass</sub>	to Node #
204	Sump	22.4	10'	27.0	22.4	0.0	-
203	Sump	20.6	10'	27.0	20.6	0.0	-
202	(Manhole)						
201	(End section)						

\* See Chart 12 † input for "storm" program

III STREET FLOW (5-YR)

Node	Q <sub>5</sub>	Distribution	street slope	d	d <sub>max</sub>	comment
204	11.8	40% N = 4.7	0.32%	0.38'	0.55'	OK
		60% S = 7.1	0.32%	0.43'	0.55'	OK
203	10.9	40% N = 4.4	0.32%	0.37'	0.55'	OK
		60% S = 6.5	0.32%	0.41'	0.55'	OK

IV STREET FLOW (100-YR)

Location	Contributing Areas	Q <sub>100</sub>	Q <sub>pipe</sub>	Q <sub>street</sub>	street slope	Q <sub>max</sub> **	comment
Approaching Nodes 204 + 203 from N.	40% 204 =	9.0	0.0	17.2	0.32%	47.9	OK std. cb 0.3' wk. gr.
	40% 203 =	8.2					
Approaching Nodes 204 + 203 from S.	60% 204 =	13.4	0.0	25.8	0.32%	47.9	OK std. cb 0.3' wk. gr.
	60% 203 =	12.4					
		25.8					

\*\* See Page 5



Date July 1, 1988 Page 5 of 8

Project Emery Park Addition

Item Drainage System 200

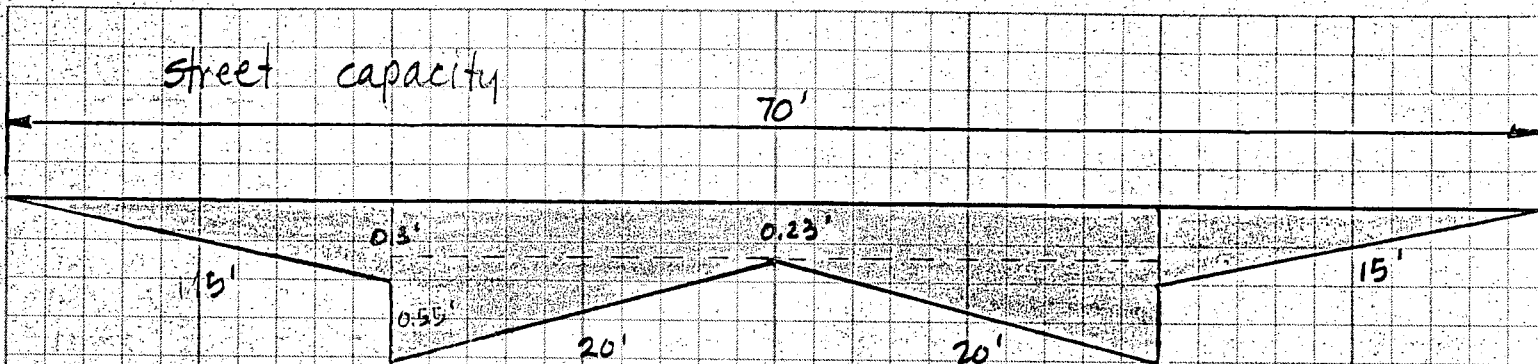

Use Manning's Eq'n  $Q = 1.486/n A R^{2/3} S^{1/2}$

$$n = \frac{(2 \times 14.5 \times 0.035) + (2 \times 3.05 \times 0.013) + (2 \times 18 \times 0.016)}{71.1}$$

$$= 0.0235$$

$$A = (2 \times \frac{1}{2} \times 0.3 \times 15) + (0.23 \times 40) + (2 \times \frac{1}{2} \times 20 \times 0.62)$$

$$= 26.10$$

$$P = 71.1$$

$$R = A/P = 26.10/71.1 = 0.3671 \quad R^{2/3} = 0.513$$

$$Q = \frac{1.486}{0.0235} \times 26.10 \times 0.513 \times S^{1/2}$$

$$Q = 846.7 \sqrt{S}$$



7/8

Date: 07-07-1988  
Time: 14:32:06

Input File: emery200

emery park addition  
drainage plan  
system 200 analysis

Storm Frequency = 100-Year

\* \* \* HYDROLOGY \* \* \*

Tributary Area										Hydrology Summation				Conduit Data			
Node to Node	C	Area (Ac)	Slope (%)	Length (Ft)	TC(θ) (Min)	I(θ) (In/Hr)	Q(θ) (CFS)	TC (Min)	I (In/Hr)	Q (CFS)	Sum Q (CFS)	Size	Velocity (Ft/Sec)	Length (Ft)	TT (Min)	TT+TC (Min)	
204 203	0.80	3.90	0.00	0.0	15.00	0.97	22.40	15.00	0.97	22.40	22.40	24"	7.13	45.00	0.11	15.11	
203 202	0.80	3.50	0.00	0.0	15.00	0.97	20.60	15.11	0.95	20.54	42.94	36"	6.08	250.00	0.69	15.79	
202 201	0.00	0.00	0.00	0.0	0.00	0.00	0.00	15.79	0.00	0.00	42.94	36"	6.08	20.00	0.05	15.85	

\*\*\*\*\*

8/8

Date: 07-07-1988  
Time: 14:32:06

Input File: emery200

emery park addition  
drainage plan  
system 200 analysis

Storm Frequency = 100-Year

\* \* \* HYDRAULICS \* \* \*

```

*****
Node      Hyd-Slope  Friction   Bend      Transition  Manhole  Deflection  Junction  Total  Hyd-61  Desired  Diff.
          (Ft/Ft)    (Ft)      (Ft)      (Ft)        (Ft)     (Ft)       (Ft)     (Ft)   Elevation Elevation (Ft)
*****
204      0.00980    0.4412    0.0000    0.0000     0.0000    0.0000     0.0000    0.4412  87.1294  87.0000  -0.13
203      0.00415    1.0364    0.0000    0.0433     0.0000    0.0000     0.6516    1.7312  86.6882  87.0000  0.31
202      0.00415    0.0829    0.0000    0.0000     0.0287    0.1247     0.0208    0.2571  84.9571  86.7000  1.74
201      0.00000    0.0000    0.0000    0.0000     0.0000    0.0000     0.0000    0.0000  84.7000  84.7000  0.00
*****

```



Date July 1, 1988 Page 1 of 7

Project Emerg Park Addition

Item Drainage Detention

Generate inflow hydrograph at detention area.

Contributing Areas:

- ① SWS System 100
- ② SWS System 200
- ③ South portion lots 3 & 4, B1K1 (by surface drain or private SWS)
- ④ East portion lot 2, B1K1 (by surface drain or private SWS)
- ⑤ Reserve "A" (Detention Area)

Runoff:

① 45 cfs @  $t_c = 15.6$  min.

② 43 cfs @  $t_c = 15.9$  min.

③  $Q = CIA$  where  $c = 0.7$   $I_{100} = 7.37$   $A = 3.67$   
 $Q = 0.7 \times 7.37 \times 3.67 = 18.9$  cfs  
use 19

④  $Q = CIA$  where  $c = 0.7$   $I_{100} = 7.37$   $A = 1.35$   
 $Q = 0.7 \times 7.37 \times 1.35 = 7$  cfs

⑤  $Q = CIA$  where  $c = 0.95$   $I_{100} = 7.37$   $A = 3.14$   
 $Q = 0.95 \times 7.37 \times 3.14 = 22$  cfs



Date July 1, 1988 Page 2 of 7

Project Emery Park Add

Item Drainage Detention

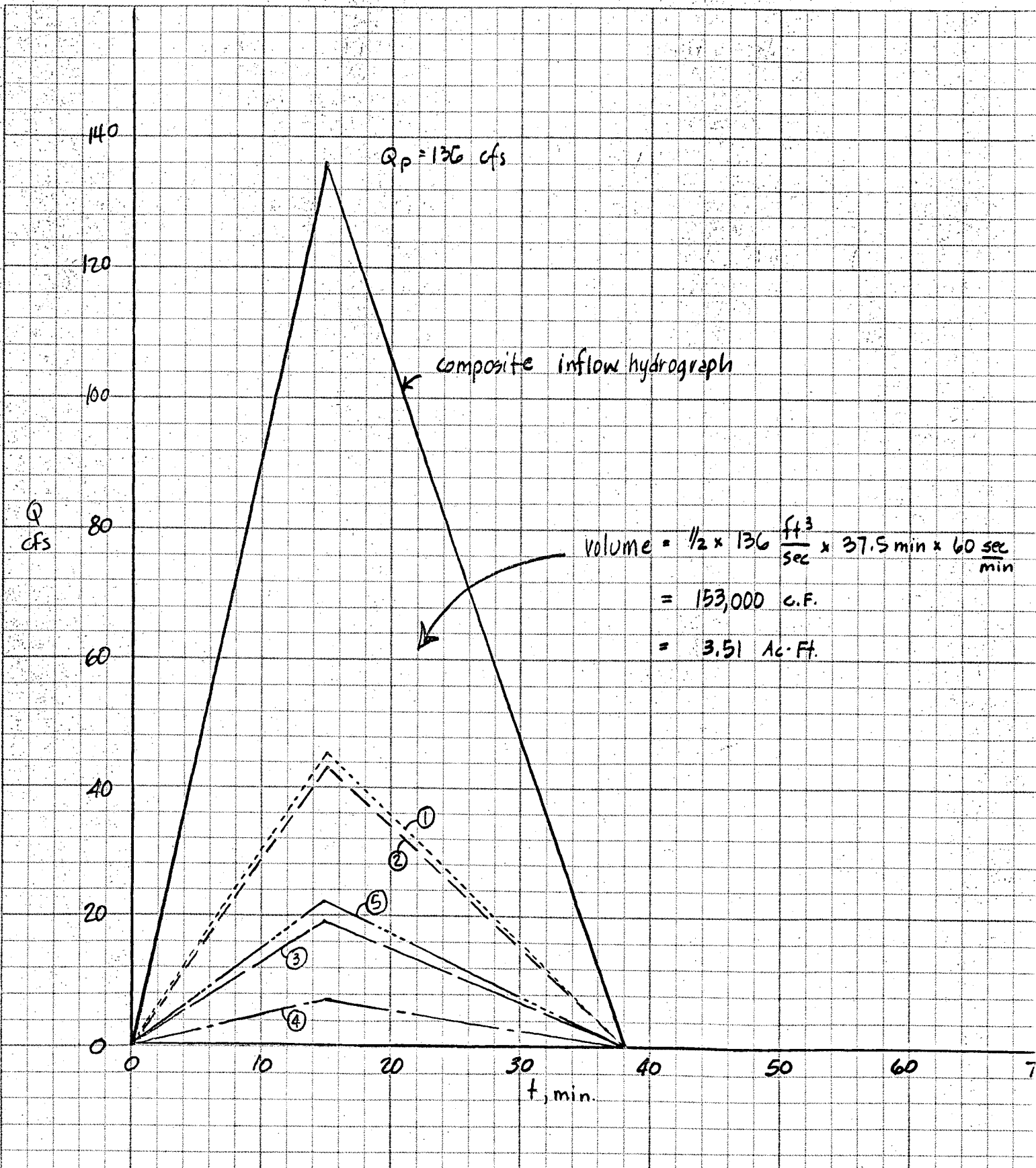



Date July 1, 1988 Page 3 of 7

Project Emery Park Addition

Item Drainage Detention

STAGE - STORAGE OF DETENTION AREA

ELEV.	STAGE	elev.	Area	Ad	Vol.	Σ Vol
		static pool 181.7	1.9 Ac.	0	0	0
		top bank 184.7	2.4	3.0	6.4	6.4

185.7 4

184.7 3

183.7 2

182.7 1

181.7 0

0 1 2 3 4 5 6

STORAGE (AC-FT)

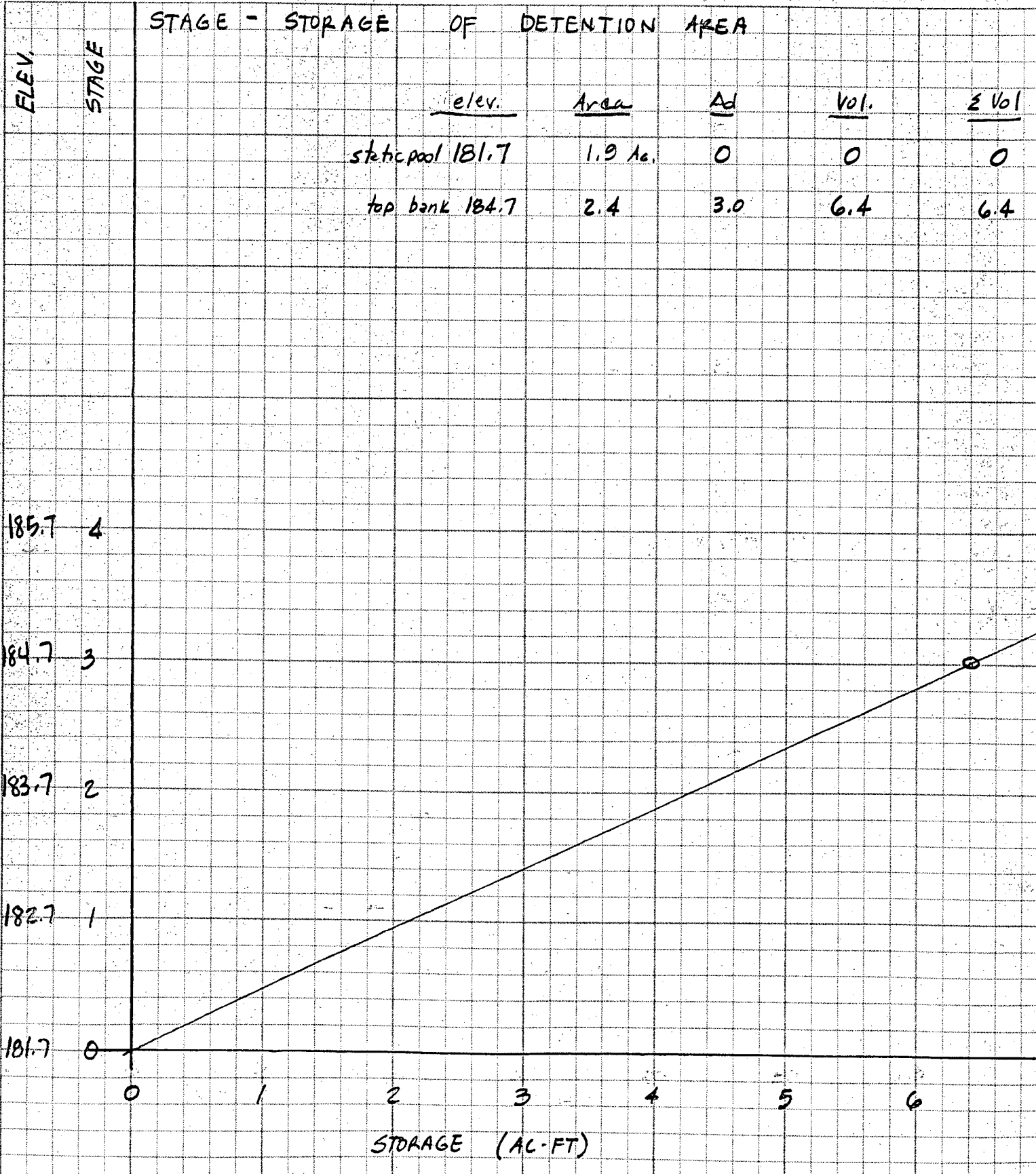

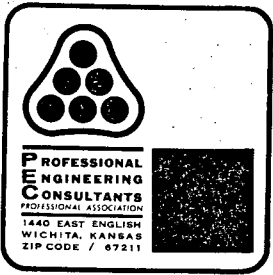

Date July 1, 1988 Page 4 of 7

Project Emery Park Add.

Item Drainage Detention

STAGE - DISCHARGE (DISCHARGE PIPE = 15" RCP)  
inlet control

<u>STAGE</u>	<u>HW</u>	<u>HW/D</u>	<u>Q</u>
1.0	1.0	0.80	3
2.0	2.0	1.60	7
3.0	3.0	2.40	9
4.0	4.0	3.20	11

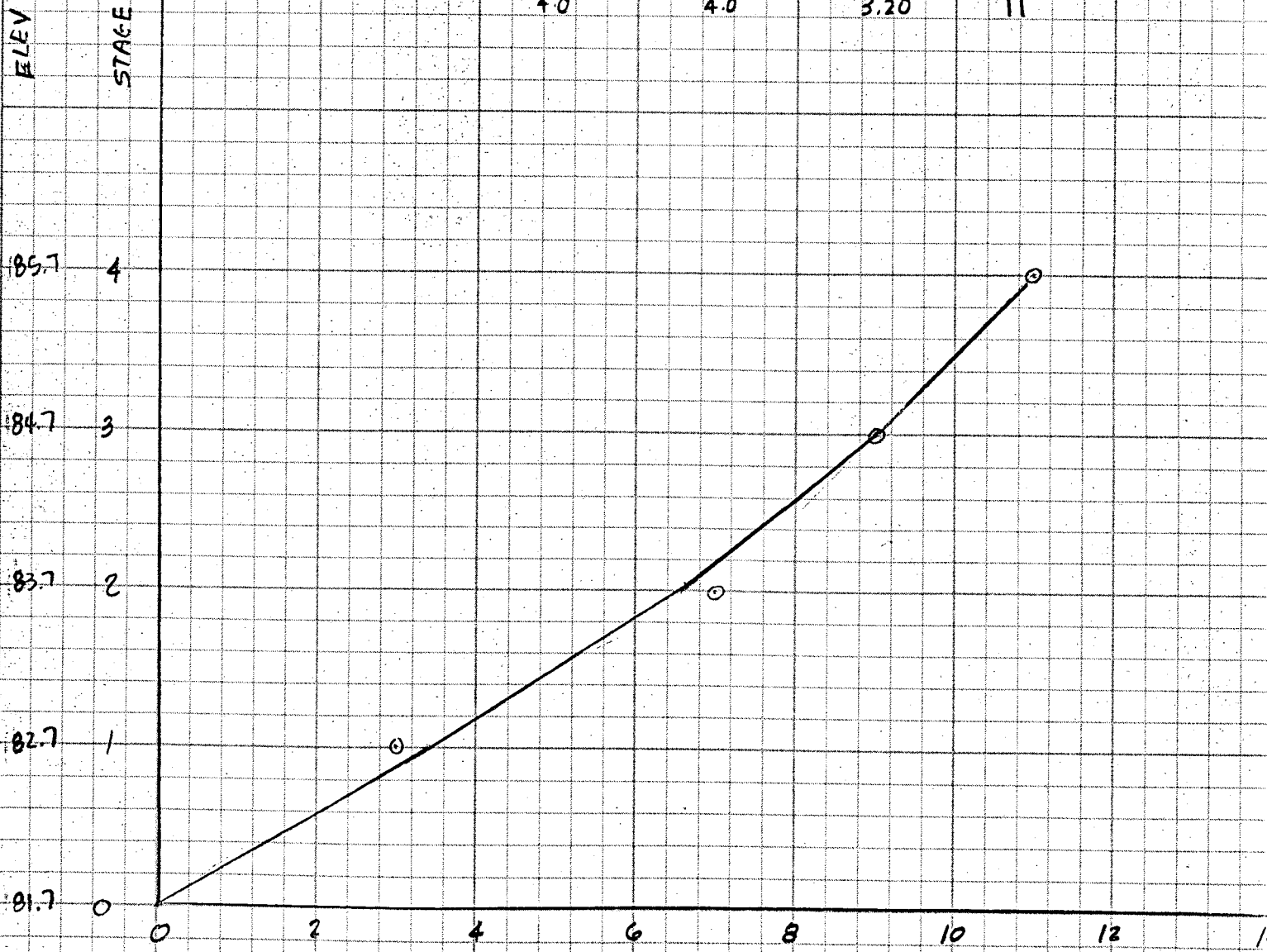

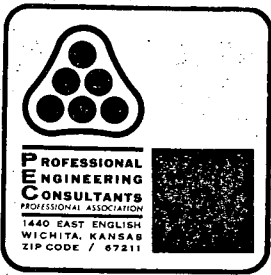

Date July 1, 1988 Page 5 of 7

Project Emery Park Add.

Item Drainage Detention

stage	Elev.	Storage (S) Ac-Ft.	Storage (S) Ac-In	Outflow (O) cfs	$\frac{2S}{\Delta T}$	$\frac{2S}{\Delta T}$	$\frac{2S}{\Delta T} + O$
0	81.7	0.0	0.0	0.0	0.0	0.0	0.0
1	82.7	2.1	25.2	3	50.4	607	610
2	83.7	4.2	50.4	7	100.8	1214	1221
3	84.7	6.4	76.8	9	153.6	1851	1860

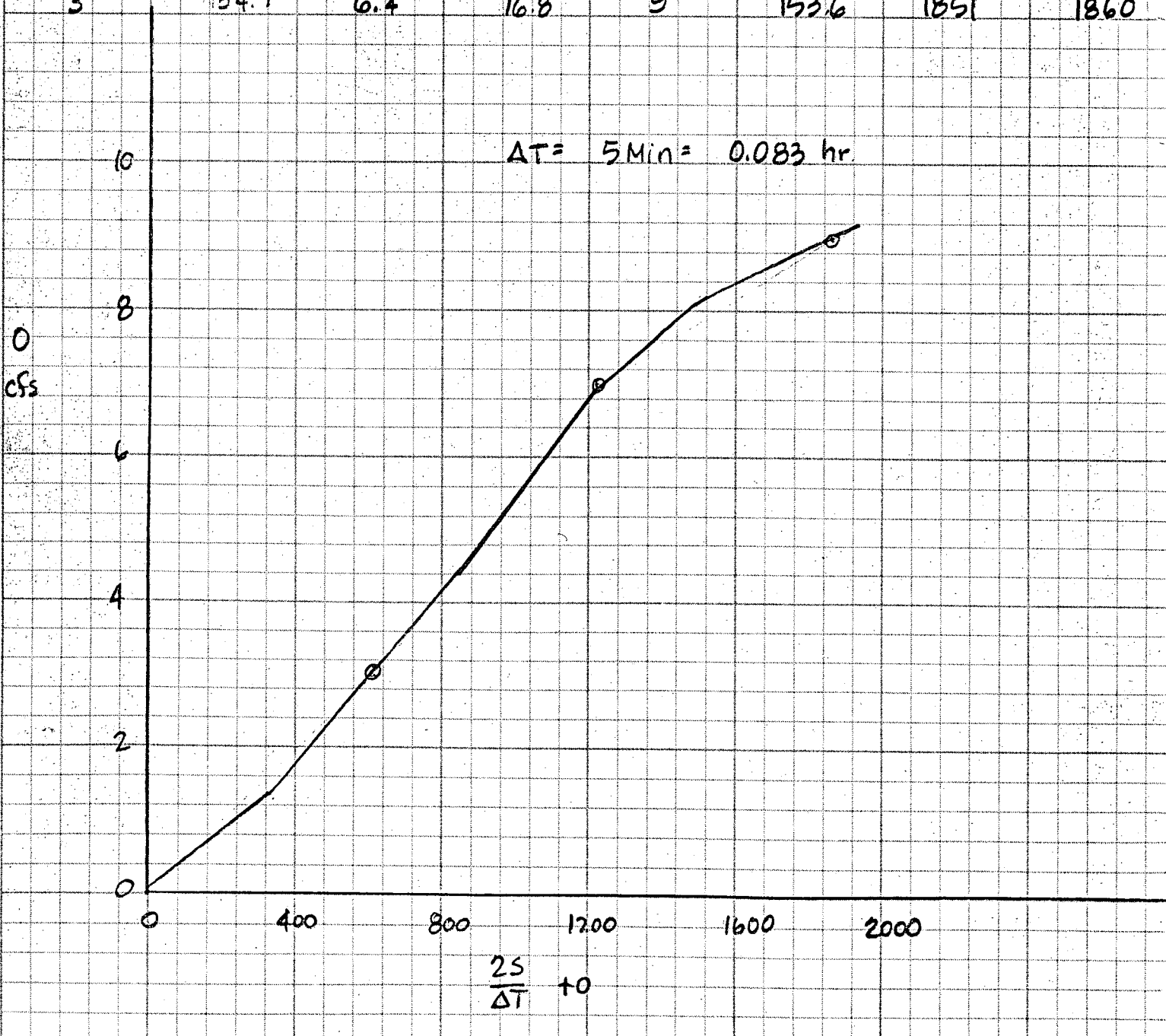

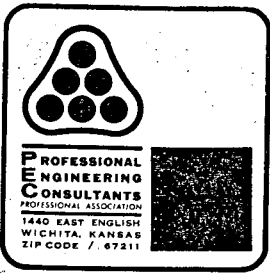

Date July 1, 1988 Page 6 of 7

Project Emery Park Addition

Item Drainage Detention

Time hr.	$I_n$ cfs	$I_n + I_m$	$\frac{2S}{\Delta T} - 0$	$\frac{2S}{\Delta T} + 0$	0	HW	Elev.
0	0	45	0	0	0	0	181.7
5	0.083	45	43	45	1	0.3'	182.0
10	0.167	90	176	178	1	0.3'	182.0
15	0.250	136	398	402	2	0.6'	182.3
20	0.333	182	636	640	3	0.9'	182.6
25	0.416	76	123	810	4	1.2'	182.9
30	0.500	47	65	923	5	1.5'	183.2
35	0.583	18	18	978	5	1.5'	}
40	0.666	0	0	986	5	1.5'	
45	0.750	0	0	976	5	1.5'	
50	0.833	0	0	966	5	1.5'	
55	0.916	0	0	956	5	1.5'	
60	1.000	0	0	946	5	1.5'	
65	1.083	0	0	936	5	}	
70	1.167	0	0	926	5		
75	1.250	0	0	916	5		
80	1.333	0	0	906	5		
85	1.416	0	0	896	5		
90	1.500	0	0	888	4	1.2'	182.9
95	1.583	0	0	880	4	}	}
100	1.666	0	0	880	4		

Etc Etc

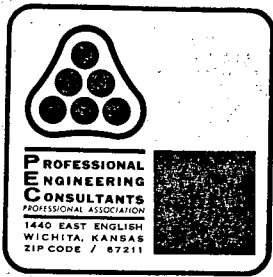

Date July 1, 1988 Page 7 of 7

Project Emery Park Addition

Item Drainage - Detention

SUMMARY

$Q_{\text{peak in}} = 136 \text{ cfs}$

$Q_{\text{out}} = 5 \text{ cfs}$

Static Pool = 81.7

DWS<sub>100</sub> = 83.2

Top Bank = 84.2 Min.

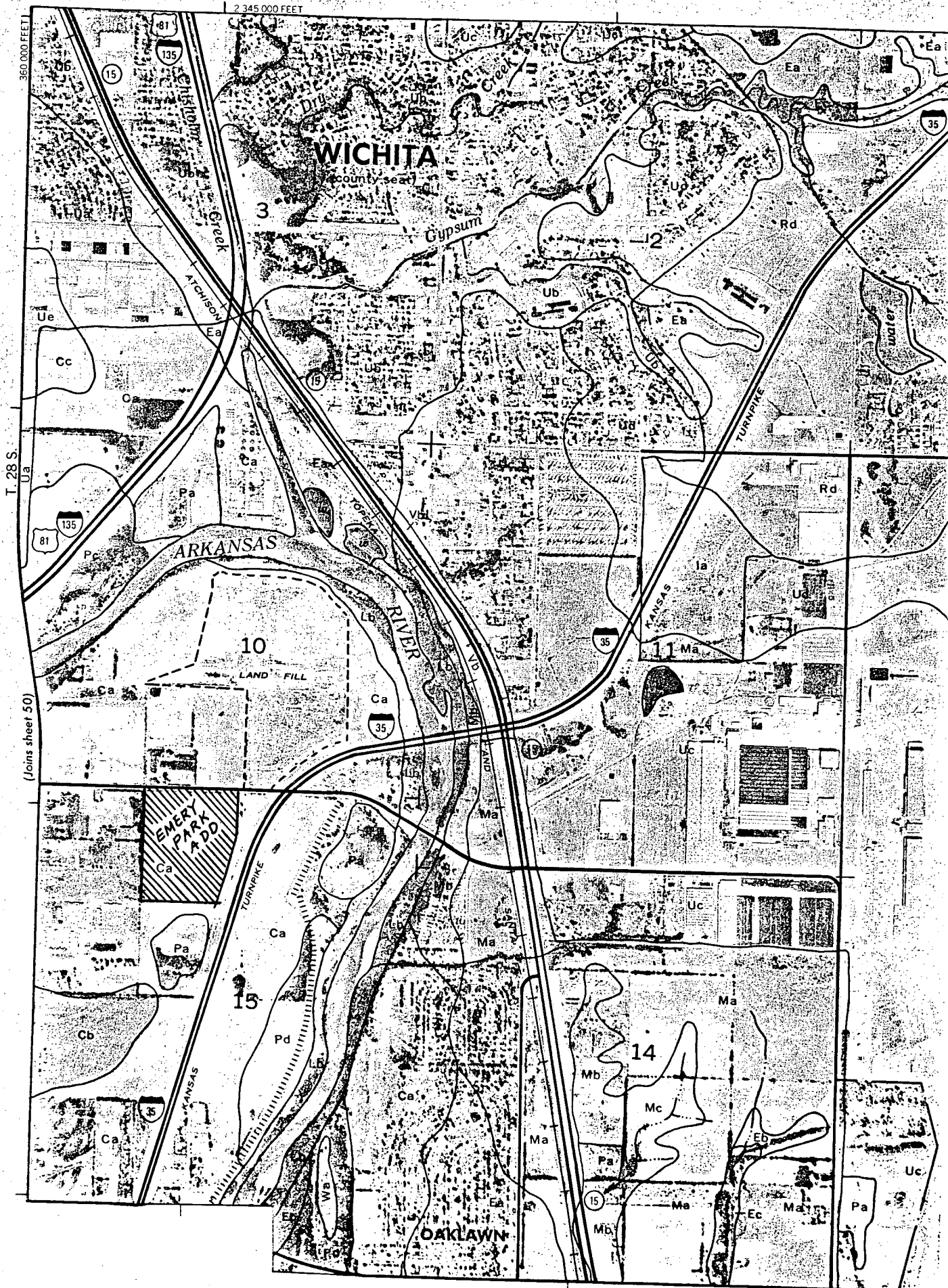

T. 28 S.  
Ua  
(Joins sheet 50)

360,000 FEET

2 345 000 FEET

## EXHIBIT NO. 1

## SOIL LEGEND

<u>SYMBOL</u>	<u>HYDROLOGIC GROUP</u>	<u>NAME</u>
Aa	B	Albion-Shellabarger sandy loams, 1 to 4 percent slopes
Ab	B	Albion and Shellabarger sandy loams, 7 to 15 percent slopes
Ba	C	Blanket silt loam, 0 to 1 percent slopes
Bb	C	Blanket silt loam, 1 to 3 percent slopes
Ca	B	Canadian fine sandy loam
Cb	B	Canadian-Waldeck fine sandy loams
Cc	D	Carwile fine sandy loam
Cd	B	Clark-Ost clay loams, 1 to 4 percent slopes
Ce	C	Cline silty clay, 3 to 6 percent slopes
Ea	B	Elandco silt loam
Eb	B	Elandco silt loam, occasionally flooded
Ec	B	Elandco silt loam, frequently flooded
Fa	B	Farnum loam, 0 to 1 percent slopes
Fb	B	Farnum loam, 1 to 3 percent slopes
Fc	B	Farnum loam, sandy substratum, 0 to 1 percent slopes
Ga	D	Goessel silty clay, 0 to 1 percent slopes
Gb	D	Goessel silty clay, 1 to 2 percent slopes
Ia	D	Irwin silty clay loam, 1 to 3 percent slopes
Ib	D	Irwin silty clay loam, 3 to 6 percent slopes
Ic	D	Irwin silty clay loam, 2 to 6 percent slopes, eroded
La	C	Lesho loam
Lb	A	Lincoln soils
Ma	B	Milan loam, 1 to 3 percent slopes
Mb	B	Milan form, 3 to 6 percent slopes
Mc	B	Milan clay loam, 2 to 6 percent slopes, eroded
Na	B	Naron fine sandy loam
Oc	D	Owens clay loam, 1 to 3 percent slopes
Od	D	Owens-Rock outcrop complex, 3 to 10 percent slopes
Pa		Pits
Pb	D	Plevna fine sandy loam
Pc	A	Pratt loamy fine sand, undulating
Pd	A	Pratt-Tivoli complex, rolling
Ra	D	Renfrow silty clay loam, 1 to 3 percent slopes
Rb	D	Renfrow silty clay loam, 3 to 6 percent slopes
Rc	D	Renfrow-Owens clay loams, 1 to 4 percent slopes
Rd	D	Rosehill silty clay, 1 to 3 percent slopes
Sa	B	Shellabarger sandy loam, 1 to 3 percent slopes
Sb	B	Shellabarger sandy loam, 3 to 6 percent slopes
Sc	B	Shellabarger sandy loam, 3 to 6 percent slopes, eroded
Ta	D	Tabler silty clay loam
Tb	D	Tabler-Drummond complex
Ua	B	Urban land-Canadian complex
Ub	B	Urban land-Elandco complex
Uc	B	Urban land-Farnum complex, 0 to 3 percent slopes
Ud	D	Urban land-Irwin complex, 1 to 3 percent slopes
Ue	D	Urban land-Tabler complex
Va	B	Vanoss silt loam, 0 to 1 percent slopes
Vb	B	Vanoss silt loam, 1 to 3 percent slopes
Vc	B	Vanoss silt loam, 3 to 6 percent slopes
Vd	B	Vanoss silt loam, 3 to 6 percent slopes, eroded
Ve	D	Vernon sandy loam, 1 to 3 percent slopes
Vf	D	Vernon sandy loam, 3 to 6 percent slopes
Wa	C	Waldeck sandy loam
Wb	D	Waurika silt loam

## ATTACHMENT D

## DRAINAGE CRITERIA

## CITY OF WICHITA, KANSAS

RECOMMENDED RUNOFF COEFFICIENTS FOR RATIONAL METHOD  
AND PERCENT IMPERVIOUS FOR UNIT HYDROGRAPH METHOD

Land Use or Surface Characteristics	Percent Impervious	Frequency			
		<u>2</u>	<u>5</u>	<u>10</u>	<u>100</u>
<b>1. Business:</b>					
Downtown Areas	95	0.84	0.85	0.87	0.91
Neighborhood Areas	70	0.68	0.69	0.73	0.80
<b>2. Residential:</b>					
<u>Single Family (Soil Group D)</u>					
1/8 Acre	50	0.57	0.61	0.66	0.79
1/4 Acre	38	0.50	0.54	0.62	0.76
1/3 Acre	30	0.46	0.50	0.59	0.73
1/2 Acre	25	0.42	0.48	0.56	0.72
3/4 Acre	22	0.42	0.46	0.55	0.71
1 Acre	20	0.41	0.45	0.54	0.71
<u>Multi-Family (Soil Group D)</u>					
Multi-Unit (detached)	60	0.62	0.66	0.72	0.82
Multi-Unit (attached)	65	0.64	0.68	0.73	0.83
Apartments	75	0.70	0.73	0.79	0.86
<u>Single Family (Soil Group C)</u>					
1/8 Acre	50	0.55	0.58	0.64	0.73
1/4 Acre	38	0.48	0.51	0.57	0.68
1/3 Acre	30	0.43	0.46	0.53	0.65
1/2 Acre	25	0.40	0.43	0.50	0.63
3/4 Acre	22	0.39	0.42	0.49	0.62
1 Acre	20	0.37	0.40	0.48	0.61
<u>Multi-Family (Soil Group C)</u>					
Multi-Unit (detached)	60	0.60	0.63	0.69	0.77
Multi-Unit (attached)	65	0.63	0.66	0.71	0.79
Apartments	75	0.68	0.72	0.77	0.83
<u>Single-Family (Soil Group B)</u>					
1/8 Acre	50	0.52	0.54	0.59	0.67
1/4 Acre	38	0.44	0.46	0.52	0.61
1/3 Acre	30	0.39	0.41	0.47	0.57
1/2 Acre	25	0.36	0.38	0.44	0.54
3/4 Acre	22	0.34	0.36	0.42	0.52
1 Acre	20	0.33	0.35	0.40	0.51
<u>Multi-Family (Soil Group B)</u>					
Multi-Unit (detached)	60	0.58	0.60	0.65	0.72
Multi-Unit (attached)	65	0.61	0.64	0.68	0.75
Apartments	75	0.67	0.70	0.74	0.80

Land Use or Surface Characteristics	Percent Impervious	Frequency			
		<u>2</u>	<u>5</u>	<u>10</u>	<u>100</u>
<u>Single Family (Soil Group A)</u>					
1/8 Acre	50	0.47	0.50	0.54	0.60
1/4 Acre	38	0.39	0.41	0.45	0.52
1/3 Acre	30	0.33	0.35	0.39	0.47
1/2 Acre	25	0.30	0.31	0.35	0.44
3/4 Acre	22	0.28	0.29	0.33	0.42
1 Acre	20	0.26	0.28	0.32	0.40
<u>Multi-Family (Soil Group A)</u>					
Multi-Unit (detached)	60	0.55	0.57	0.61	0.67
Multi-Unit (attached)	65	0.58	0.60	0.64	0.70
Apartments	75	0.65	0.68	0.72	0.77
3. Industrial:					
Light Areas	70	0.68	0.69	0.73	0.80
Heavy Areas	80	0.74	0.76	0.79	0.84
4. Playgrounds:	15	0.33	0.35	0.42	0.55
5. Schools:	40	0.49	0.51	0.56	0.66
6. Railroad Yard Areas:	30	0.43	0.45	0.50	0.62
7. Undeveloped Urban Areas: Offsite Flow Analysis (when land use not defined)	45	0.52	0.54	0.59	0.68
8. Streets:					
Paved	99	0.87	0.88	0.90	0.93
Gravel	00	0.24	0.26	0.33	0.48
9. Drive, Parking Lots and Walks:	96	0.87	0.87	0.88	0.89
10. Roofs:	90	0.80	0.85	0.90	0.93
11. Urban Lawn Areas (See Note No. 1 below):					
<u>Soil Group A</u>					
Slope less than 1%	00	0.08	0.09	0.13	0.23
Slope 1% to 4%	00	0.12	0.13	0.17	0.27
Slope more than 4%	00	0.16	0.17	0.21	0.31
<u>Soil Group B</u>					
Slope less than 1%	00	0.16	0.18	0.24	0.37
Slope 1% to 4%	00	0.20	0.22	0.28	0.41
Slope more than 4%	00	0.24	0.26	0.32	0.45
<u>Soil Group C</u>					
Slope less than 1%	00	0.24	0.27	0.35	0.51
Slope 1% to 4%	00	0.26	0.29	0.37	0.53
Slope more than 4%	00	0.28	0.31	0.39	0.55

Land Use or Surface Characteristics	Percent Impervious	Frequency			
		<u>2</u>	<u>5</u>	<u>10</u>	<u>100</u>
<u>Soil Group D</u>					
Slope less than 1%	00	0.28	0.33	0.43	0.63
Slope 1% to 4%	00	0.30	0.35	0.45	0.65
Slope more than 4%	00	0.32	0.37	0.47	0.67

Note No. 1: Coefficients shown in the above table are for pervious open space areas with thick turf which includes pervious areas in parks and cemeteries. Coefficients shown above must be increased 0.02 for use with agricultural pasture areas. Coefficients shown above must be reduced by 0.04 for use with agricultural cultivated areas. Group A soils are well-drained, coarse textured sands with high infiltration rates. Group B soils are moderately well-drained, moderately coarse textured soils with moderate infiltration rates. Group C soils are moderately poor-drained, moderately fine textured soils with slow infiltration rates. Group D soils are poor-drained, fine textured soils with very slow infiltration rates.

GENERAL NOTE: These Rational Formula Coefficients may not be valid for basins 320 acres or larger.

April 15, 1986

ATTACHMENT A  
DRAINAGE CRITERIA MANUAL

CITY OF WICHITA, KANSAS

RAINFALL INTENSITY TABLE FOR SEDGWICK COUNTY, KANSAS

The following tabulation contains rainfall intensity in inches per hour as derived from ESSA Weather Bureau Technical Paper 40 Modified to NWS Hydro-35, 1977 During First Hour

DURATION IN MINUTES	RETURN PERIODS OF						
	1-YR	2-YR	5-YR	10-YR	25-YR	50-YR	100-YR
5	4.18	5.57	6.53	7.41	8.52	9.48	10.32
6	3.99	5.32	6.25	7.09	8.16	9.09	9.89
7	3.81	5.09	5.99	6.81	7.84	8.74	9.50
8	3.66	4.89	5.75	6.55	7.55	8.42	9.15
9	3.52	4.70	5.54	6.31	7.28	8.13	8.83
10	3.39	4.52	5.34	6.09	7.04	7.86	8.54
11	3.27	4.36	5.16	5.89	6.81	7.61	8.27
12	3.18	4.21	4.99	5.71	6.60	7.38	8.02
13	3.05	4.08	4.84	5.53	6.41	7.17	7.79
14	2.96	3.95	4.69	5.37	6.23	6.97	7.57
15	2.87	3.83	4.56	5.22	6.06	6.78	7.37
16	2.78	3.72	4.43	5.08	5.90	6.60	7.18
17	2.71	3.61	4.31	4.95	5.75	6.44	7.00
18	2.63	3.51	4.20	4.83	5.61	6.29	6.84
19	2.56	3.42	4.10	4.71	5.47	6.14	6.68
20	2.50	3.33	4.00	4.60	5.35	6.00	6.53
21	2.44	3.25	3.90	4.50	5.23	5.87	6.39
22	2.38	3.17	3.81	4.40	5.12	5.75	6.26
23	2.32	3.10	3.73	4.31	5.01	5.63	6.13
24	2.27	3.03	3.65	4.22	4.91	5.52	6.01
25	2.22	2.96	3.57	4.13	4.81	5.41	5.90
26	2.20	2.90	3.50	4.05	4.72	5.31	5.79
27	2.16	2.84	3.43	3.98	4.63	5.21	5.69
28	2.14	2.78	3.37	3.90	4.55	5.12	5.59
29	2.11	2.72	3.30	3.83	4.47	5.03	5.49
30	2.08	2.67	3.24	3.76	4.39	4.94	5.40
31	2.05	2.62	3.19	3.70	4.32	4.86	5.32
32	2.02	2.57	3.10	3.63	4.25	4.79	5.22
33	1.99	2.52	3.05	3.57	4.18	4.71	5.14
34	1.96	2.48	3.01	3.51	4.11	4.63	5.07
35	1.93	2.44	2.98	3.46	4.05	4.56	5.00
36	1.91	2.39	2.93	3.41	3.99	4.50	4.93
37	1.89	2.35	2.88	3.36	3.93	4.43	4.86
38	1.87	2.32	2.84	3.31	3.87	4.37	4.79
39	1.85	2.28	2.80	3.26	3.82	4.31	4.73
40	1.83	2.24	2.76	3.22	3.76	4.25	4.66
41	1.81	2.21	2.72	3.17	3.71	4.19	4.60
42	1.79	2.18	2.68	3.13	3.66	4.13	4.54
43	1.77	2.14	2.64	3.09	3.61	4.08	4.49
44	1.75	2.11	2.61	3.05	3.57	4.03	4.43
45	1.73	2.08	2.57	3.01	3.52	3.98	4.38

ATTACHMENT A CONTINUED  
Page 2

DURATION IN MINUTES	RETURN PERIODS OF						
	1-YR	2-YR	5-YR	10-YR	25-YR	50-YR	100-YR
46	1.70	2.05	2.54	2.97	3.48	3.93	4.33
47	1.67	2.02	2.50	2.93	3.44	3.88	4.28
48	1.66	2.00	2.47	2.90	3.39	3.84	4.23
49	1.64	1.97	2.44	2.86	3.35	3.79	4.18
50	1.61	1.95	2.41	2.83	3.32	3.75	4.13
51	1.59	1.92	2.38	2.79	3.28	3.71	4.09
52	1.56	1.89	2.35	2.76	3.24	3.67	4.05
53	1.54	1.86	2.33	2.73	3.20	3.63	4.00
54	1.52	1.84	2.30	2.70	3.17	3.59	3.96
55	1.50	1.81	2.27	2.67	3.14	3.55	3.92
56	1.47	1.79	2.25	2.64	3.10	3.51	3.88
57	1.45	1.76	2.22	2.61	3.07	3.48	3.84
58	1.43	1.74	2.20	2.59	3.04	3.44	3.81
59	1.42	1.72	2.18	2.56	3.01	3.41	3.77
60	1.40	1.69	2.15	2.53	2.98	3.37	3.73
61	1.38	1.67	2.13	2.51	2.95	3.34	3.70
62	1.36	1.65	2.11	2.48	2.92	3.31	3.67
63	1.34	1.63	2.09	2.46	2.89	3.28	3.63
64	1.33	1.61	2.07	2.44	2.86	3.25	3.60
65	1.31	1.59	2.05	2.41	2.84	3.22	3.57
66	1.30	1.57	2.03	2.39	2.81	3.19	3.54
67	1.28	1.56	2.01	2.37	2.79	3.16	3.51
68	1.26	1.54	1.99	2.35	2.76	3.13	3.48
69	1.25	1.52	1.97	2.33	2.74	3.10	3.45
70	1.24	1.50	1.95	2.31	2.71	3.08	3.42
71	1.22	1.49	1.93	2.28	2.69	3.05	3.39
72	1.21	1.47	1.92	2.26	2.67	3.02	3.36
73	1.20	1.46	1.90	2.25	2.64	3.00	3.34
74	1.18	1.44	1.88	2.23	2.63	2.98	3.31
75	1.17	1.43	1.86	2.21	2.61	2.95	3.29
76	1.16	1.41	1.85	2.19	2.58	2.93	3.26
77	1.15	1.40	1.83	2.17	2.55	2.90	3.24
78	1.13	1.38	1.82	2.15	2.53	2.88	3.22
79	1.12	1.37	1.80	2.14	2.50	2.86	3.19
80	1.11	1.36	1.79	2.12	2.48	2.84	3.16
81	1.10	1.34	1.77	2.10	2.46	2.82	3.13
82	1.09	1.33	1.76	2.08	2.43	2.79	3.10
83	1.08	1.32	1.74	2.06	2.41	2.76	3.07
84	1.07	1.31	1.73	2.04	2.39	2.74	3.04
85	1.06	1.30	1.72	2.02	2.37	2.71	3.01
86	1.05	1.28	1.70	2.00	2.34	2.69	2.99
87	1.04	1.27	1.69	1.99	2.32	2.66	2.96
88	1.03	1.26	1.68	1.97	2.30	2.64	2.93
89	1.02	1.25	1.68	1.95	2.28	2.62	2.91
90	1.01	1.24	1.66	1.93	2.26	2.59	2.88

<u>DURATION IN MINUTES</u>	<u>RETURN PERIODS OF</u>						
	<u>1-YR</u>	<u>2-YR</u>	<u>5-YR</u>	<u>10-YR</u>	<u>25-YR</u>	<u>50-YR</u>	<u>100-YR</u>
91	1.00	1.23	1.65	1.92	2.24	2.57	2.86
92	1.00	1.22	1.63	1.90	2.22	2.55	2.83
93	0.99	1.21	1.62	1.89	2.20	2.53	2.81
94	0.98	1.20	1.61	1.87	2.19	2.51	2.79
95	0.97	1.19	1.59	1.85	2.17	2.49	2.76
96	0.96	1.18	1.58	1.84	2.15	2.46	2.74
97	0.96	1.17	1.57	1.82	2.13	2.44	2.72
98	0.95	1.16	1.56	1.81	2.12	2.42	2.70
99	0.94	1.15	1.54	1.80	2.10	2.41	2.67
100	0.93	1.14	1.53	1.78	2.08	2.39	2.65
101	0.93	1.13	1.52	1.77	2.07	2.39	2.65
102	0.92	1.13	1.51	1.75	2.05	2.35	2.61
103	0.91	1.12	1.50	1.74	2.04	2.33	2.59
104	0.90	1.11	1.49	1.73	2.02	2.31	2.57
105	0.90	1.10	1.47	1.72	2.01	2.30	2.55
106	0.89	1.09	1.46	1.70	1.99	2.28	2.54
107	0.88	1.09	1.45	1.69	1.98	2.26	2.52
108	0.88	1.08	1.44	1.68	1.96	2.25	2.50
109	0.87	1.07	1.43	1.67	1.95	2.23	2.48
110	0.87	1.06	1.42	1.65	1.93	2.21	2.46
111	0.86	1.06	1.41	1.64	1.92	2.20	2.45
112	0.85	1.05	1.40	1.63	1.91	2.18	2.43
113	0.85	1.04	1.39	1.62	1.89	2.17	2.41
114	0.84	1.03	1.38	1.61	1.88	2.15	2.40
115	0.84	1.03	1.37	1.60	1.87	2.14	2.38
116	0.83	1.02	1.36	1.59	1.86	2.12	2.36
117	0.82	1.01	1.36	1.58	1.84	2.11	2.35
118	0.82	1.01	1.35	1.57	1.83	2.09	2.33
119	0.81	1.00	1.34	1.56	1.82	2.08	2.32
120	0.81	0.99	1.33	1.55	1.81	2.07	2.30

<u>DURATION IN HOURS</u>	<u>RETURN PERIODS OF</u>						
	<u>1-YR</u>	<u>2-YR</u>	<u>5-YR</u>	<u>10-YR</u>	<u>25-YR</u>	<u>50-YR</u>	<u>100-YR</u>
2	0.81	0.99	1.33	1.55	1.81	2.07	2.30
3	0.59	0.72	0.97	1.13	1.32	1.51	1.68
4	0.47	0.58	0.78	0.91	1.06	1.21	1.35
5	0.40	0.49	0.66	0.77	0.89	1.02	1.14
6	0.35	0.42	0.57	0.67	0.78	0.89	0.99
8	0.28	0.34	0.46	0.53	0.62	0.71	0.79
10	0.23	0.29	0.39	0.45	0.52	0.60	0.67
12	0.20	0.25	0.33	0.39	0.45	0.52	0.58
18	0.15	0.18	0.24	0.28	0.33	0.38	0.42
24	0.12	0.15	0.20	0.23	0.27	0.31	0.34

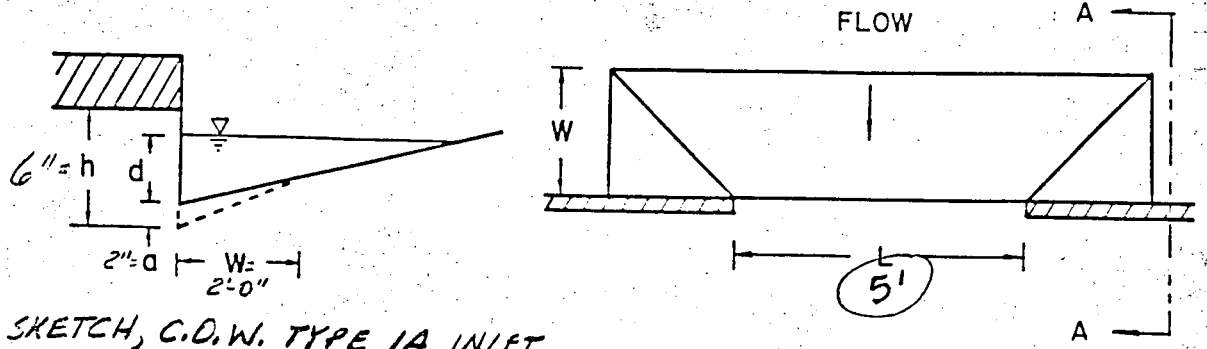

DEF. SKETCH, C.D.W. TYPE 1A INLET

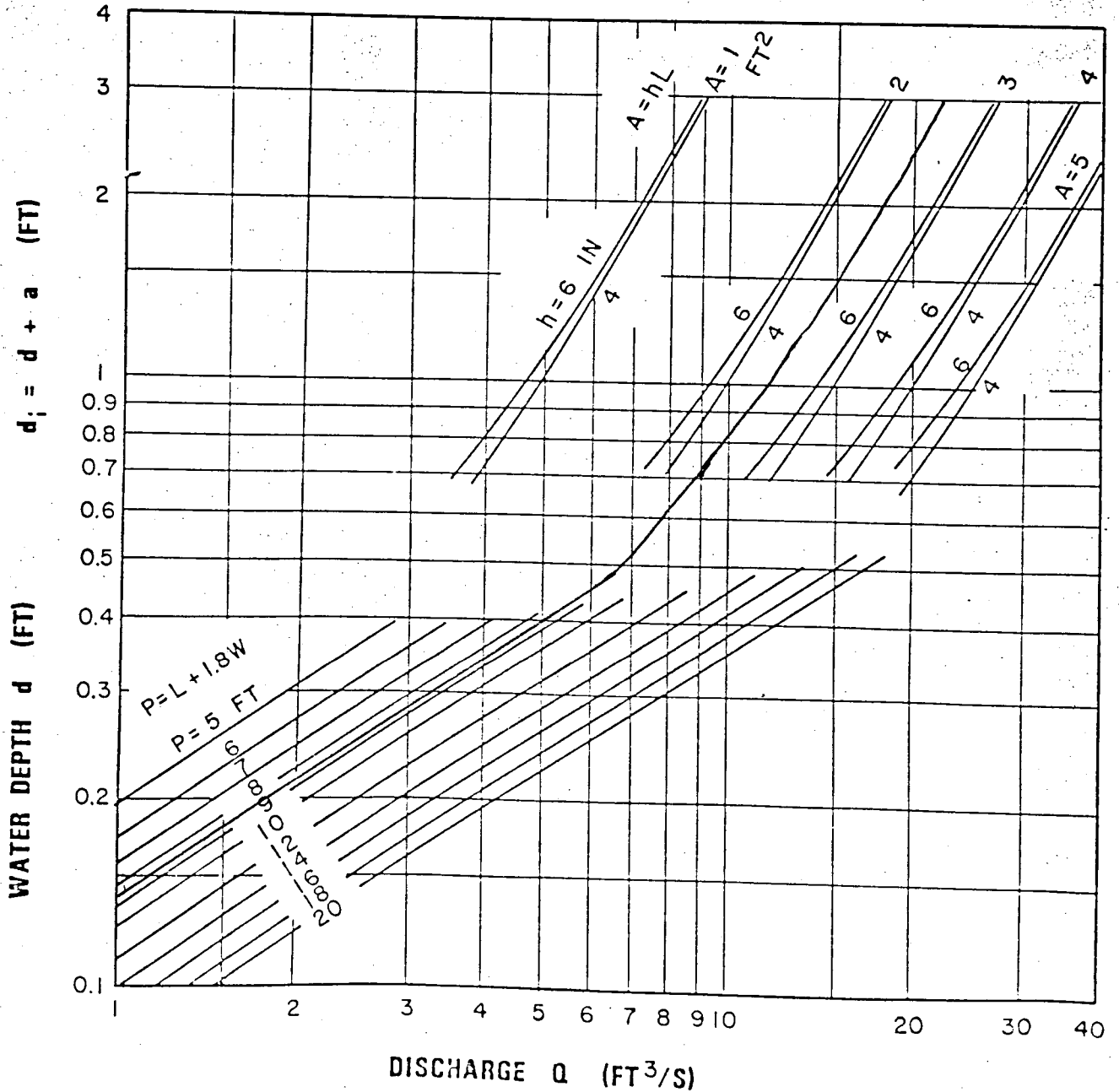
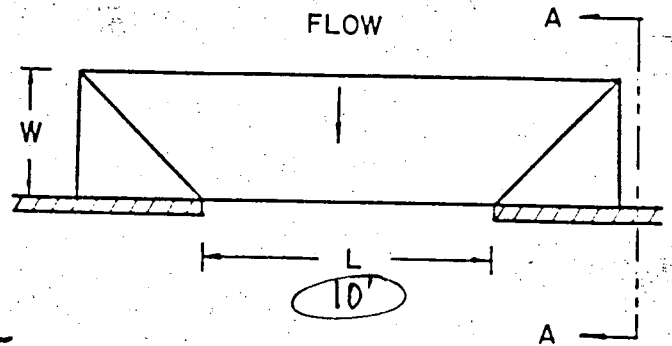
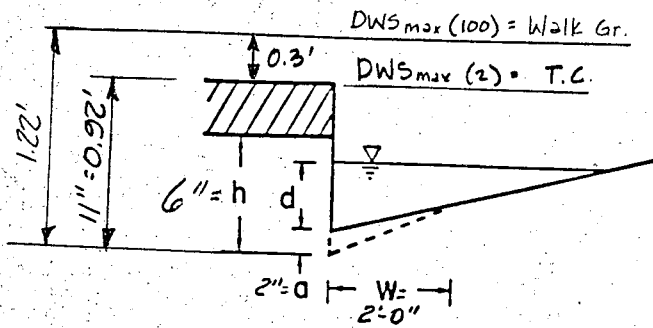

CHART 12. Depressed curb-opening inlet capacity in sump locations.

FROM: HEC-12; DRAINAGE OF HIGHWAY PAVEMENTS, FHWA, MAR, 1984



DEF. SKETCH, C.D.W. TYPE 1A INLET

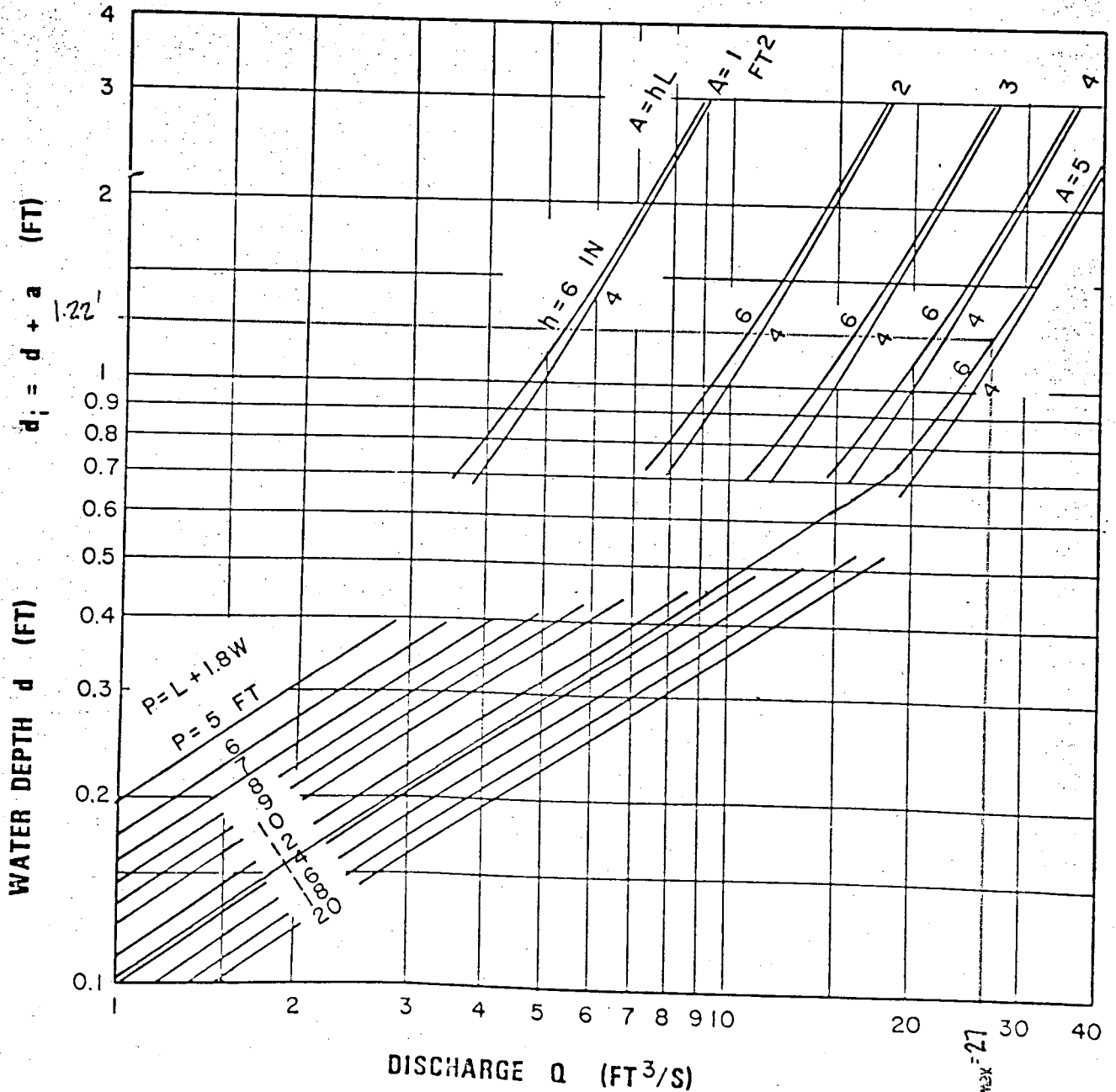

CHART 12. Depressed curb-opening inlet capacity in sump locations.

FROM: HEC-12, DRAINAGE OF HIGHWAY PAVEMENTS, FHWA, MAR, 1974

Emery Park

$x\text{-Slope} = 3/8 \text{ "/>1' = 0.03125 \text{ '}/1'$

$z = 1/x\text{-Slope} = 1/0.03125 = 32$

$n = 0.016$

$z/n = 32/0.016 = 2000$

Chart 1

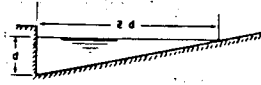

EQUATION:  $Q = 0.56 \left(\frac{z}{n}\right) s^{3/2} d^{5/2}$   
 $n$  IS ROUGHNESS COEFFICIENT IN MANNING  
 FORMULA APPROPRIATE TO MATERIAL IN  
 BOTTOM OF CHANNEL  
 $z$  IS RECIPROCAL OF CROSS SLOPE  
 REFERENCE: H. R. B. PROCEEDINGS 1948,  
 PAGE 150, EQUATION (14)

EXAMPLE (SEE INSTRUCTION 1)

GIVEN:  $s = 0.03$   
 $z = 24$   
 $n = .02$   $z/n = 1200$   
 $Q = 20 \text{ CFS}$   
 FIND:  $d = 0.22$  BY FOLLOWING  
 DASHED LINES

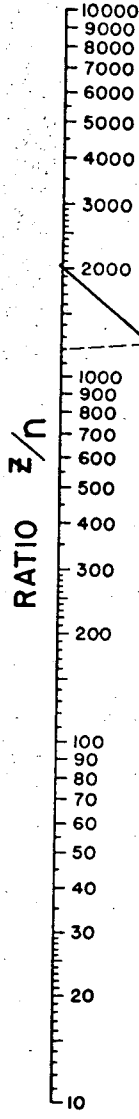

TURNING LINE

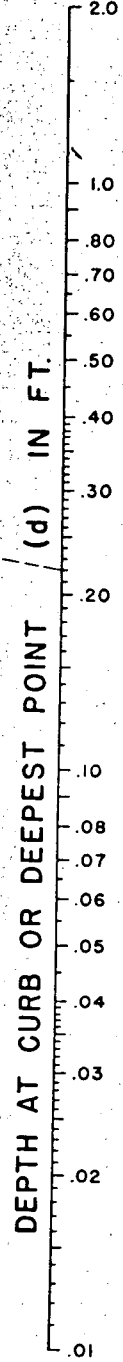

INSTRUCTIONS

- CONNECT  $z/n$  RATIO WITH SLOPE (S) AND CONNECT DISCHARGE (Q) WITH POINT WHERE LINE CROSSES TURNING LINE READ DEPTH AT CURB (d) Q CAN BE FOUND FROM d BY CONNECTING d WITH CROSSING OF TURNING LINE.
- FOR SHALLOW V-SHAPED CHANNEL AS SHOWN USE NOMOGRAPH AS EXPLAINED IN INSTRUCTION 1 BUT WITH  $z = \frac{T}{d}$ .
- TO DETERMINE DISCHARGE  $Q_x$  IN PORTION OF CHANNEL HAVING WIDTH X: DETERMINE DEPTH d FOR TOTAL DISCHARGE IN ENTIRE SECTION AS EXPLAINED IN 1. THEN USE NOMOGRAPH TO DETERMINE  $Q_b$  IN SECTION OF WIDTH b FOR DEPTH  $d' = d \cdot \left(\frac{x}{T}\right)$ . THEN  $Q_x = Q - Q_b$ .
- TO DETERMINE DISCHARGE ( $Q_x$ ) IN COMPOSITE SECTION: FOLLOW INSTRUCTION 3. TO OBTAIN DISCHARGE ( $Q_a$ ) IN SECTION a AT ASSUMED DEPTH  $d$  BASED ON AN EXTENSION OF SLOPE RATIO  $z_a$  TO INTERSECT WATER SURFACE; OBTAIN  $Q_b$  FOR SLOPE RATIO  $z_b$  AND DEPTH  $d'$ :  $d' = d \cdot \frac{z_a}{z_b}$  THEN  $Q_x = Q_a + Q_b$ .

