

**DRAINAGE
PLAN**

**SMITHMOOR SIXTH ADD.
SMITHMOOR SEVENTH ADD.
WICHITA, SEDGWICK COUNTY,
KANSAS**

Date: July 22, 1997

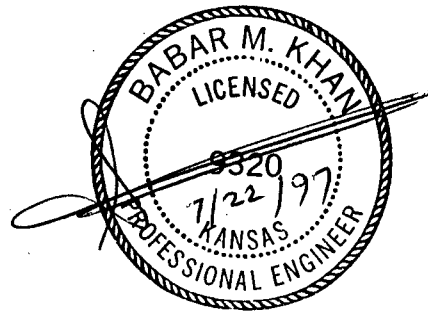



MUNICIPAL ENGINEERS, P.A.
Civil Engineers & Land Surveyors

July 22, 1997

Ms. Vicki Huang, P.E.
City Engineer's Office
City Hall - 7th Floor
455 North Main Street
Wichita, Kansas 67202

Re: **Drainage Plan for Smithmoor Sixth & Smithmoor Seventh Additions
Wichita, Sedgwick County, Kansas**

Dear Ms. Huang:

Attached please find drainage plan for the two referenced plats.

1. Introduction:

Smithmoor Sixth Addition is a replat of Smithmoor Fifth Addition. Most of Smithmoor Fifth Addition has been developed. Smithmoor Third Addition, Fifth Addition and Seventh Addition drain to a storm sewer system which was built in Smithmoor Fourth Addition. Drainage plan for Smithmoor Fourth Addition, dated June 22, 1994 included areas which are platted as Smithmoor fifth Addition, Sixth Addition and approximately 2/3 of Seventh Addition. Balance of Seventh Addition will drain to east into a future drainage channel (Please refer to overall development plan).

Attached drainage calculations confirm adequacy of existing storm sewers.

Please call me if you have questions or need additional information.

Sincerely,
MUNICIPAL ENGINEERS, P.A.

A handwritten signature in black ink, appearing to read 'Babar M. Khan'. The signature is written in a cursive style with a large, looping initial 'B' and a long, sweeping horizontal stroke that extends to the right.

Babar M. Khan, P.E., L.S.

DRAINAGE PLAN

SMITHMOOR SIXTH & SEVENTH

ADDITIONS

2.0 HYDROLOGY :

USE RATIONAL METHOD:

SOIL TYPE = I_a

HYDRO GROUP = D

LAND USE = SINGLE FAMILY

SIZE 6,600 S.F. ±

RUNOFF COEFFICIENTS:

$$C_2 = 0.55$$

$$C_{100} = 0.78$$

$$T_c = 15 \text{ MIN.}$$

$$L_2 = 3.83''$$

$$L_{100} = 7.37''$$

ATTACHMENT D

DRAINAGE CRITERIA

CITY OF WICHITA, KANSAS

RECOMMENDED RUNOFF COEFFICIENTS FOR RATIONAL METHOD
AND PERCENT IMPERVIOUS FOR UNIT HYDROGRAPH METHOD

Land Use or Surface Characteristics	Percent Impervious	Frequency			
		<u>2</u>	<u>5</u>	<u>10</u>	<u>100</u>
1. Business:					
Downtown Areas	95	0.84	0.85	0.87	0.91
Neighborhood Areas	70	0.68	<u>0.69</u>	0.73	0.80
2. Residential:					
<u>Single Family (Soil Group D)</u>					
1/8 Acre	50	0.57	0.61	0.66	0.79
1/4 Acre	38	0.50	0.54	0.62	0.76
1/3 Acre	30	0.46	0.50	0.59	0.73
1/2 Acre	25	0.42	0.48	0.56	0.72
3/4 Acre	22	0.42	0.46	0.55	0.71
1 Acre	20	0.41	0.45	0.54	0.71
<u>Multi-Family (Soil Group D)</u>					
Multi-Unit (detached)	60	0.62	0.66	0.72	0.82
Multi-Unit (attached)	65	0.64	0.68	0.73	0.83
Apartments	75	0.70	0.73	0.79	0.86
<u>Single Family (Soil Group C)</u>					
1/8 Acre	50	0.55	0.58	0.64	0.73
1/4 Acre	38	0.48	0.51	0.57	0.68
1/3 Acre	30	0.43	0.46	0.53	0.65
1/2 Acre	25	0.40	0.43	0.50	0.63
3/4 Acre	22	0.39	0.42	0.49	0.62
1 Acre	20	0.37	0.40	0.48	0.61
<u>Multi-Family (Soil Group C)</u>					
Multi-Unit (detached)	60	0.60	0.63	0.69	0.77
Multi-Unit (attached)	65	0.63	0.66	0.71	0.79
Apartments	75	0.68	0.72	0.77	0.83
<u>Single-Family (Soil Group B)</u>					
1/8 Acre	50	0.52	0.54	0.59	0.67
1/4 Acre	38	0.44	0.46	0.52	0.61
1/3 Acre	30	0.39	0.41	0.47	0.57
1/2 Acre	25	0.36	0.38	0.44	0.54
3/4 Acre	22	0.34	0.36	0.42	0.52
1 Acre	20	0.33	0.35	0.40	0.51
<u>Multi-Family (Soil Group B)</u>					
Multi-Unit (detached)	60	0.58	0.60	0.65	0.72
Multi-Unit (attached)	65	0.61	0.64	0.68	0.75
Apartments	75	0.67	0.70	0.74	0.80

April 15, 1986

ATTACHMENT A
DRAINAGE CRITERIA MANUAL

CITY OF WICHITA, KANSAS

RAINFALL INTENSITY TABLE FOR SEDGWICK COUNTY, KANSAS

The following tabulation contains rainfall intensity in inches per hour as derived from ESSA Weather Bureau Technical Paper 40 Modified to NWS Hydro-35, 1977 During First Hour

DURATION IN MINUTES	RETURN PERIODS OF						
	1-YR	2-YR	5-YR	10-YR	25-YR	50-YR	100-YR
5	4.18	5.57	6.53	7.41	8.52	9.48	10.32
6	3.99	5.32	6.25	7.09	8.16	9.09	9.89
7	3.81	5.09	5.99	6.81	7.84	8.74	9.50
8	3.66	4.89	5.75	6.55	7.55	8.42	9.15
9	3.52	4.70	5.54	6.31	7.28	8.13	8.83
10	3.39	4.52	5.34	6.09	7.04	7.86	8.54
11	3.27	4.36	5.16	5.89	6.81	7.61	8.27
12	3.18	4.21	4.99	5.71	6.60	7.38	8.02
13	3.05	4.08	4.84	5.53	6.41	7.17	7.79
14	2.96	3.95	4.69	5.37	6.23	6.97	7.57
15	2.87	3.83	4.56	5.22	6.06	6.78	7.37
16	2.78	3.72	4.43	5.08	5.90	6.60	7.18
17	2.71	3.61	4.31	4.95	5.75	6.44	7.00
18	2.63	3.51	4.20	4.83	5.61	6.29	6.84
19	2.56	3.42	4.10	4.71	5.47	6.14	6.68
20	2.50	3.33	4.00	4.60	5.35	6.00	6.53
21	2.44	3.25	3.90	4.50	5.23	5.87	6.39
22	2.38	3.17	3.81	4.40	5.12	5.75	6.26
23	2.32	3.10	3.73	4.31	5.01	5.63	6.13
24	2.27	3.03	3.65	4.22	4.91	5.52	6.01
25	2.22	2.96	3.57	4.13	4.81	5.41	5.90
26	2.20	2.90	3.50	4.05	4.72	5.31	5.79
27	2.16	2.84	3.43	3.98	4.63	5.21	5.69
28	2.14	2.78	3.37	3.90	4.55	5.12	5.59
29	2.11	2.72	3.30	3.83	4.47	5.03	5.49
30	2.08	2.67	3.24	3.76	4.39	4.94	5.40
31	2.05	2.62	3.19	3.70	4.32	4.86	5.32
32	2.02	2.57	3.10	3.63	4.25	4.79	5.22
33	1.99	2.52	3.05	3.57	4.18	4.71	5.14
34	1.96	2.48	3.01	3.51	4.11	4.63	5.07
35	1.93	2.44	2.98	3.46	4.05	4.56	5.00
36	1.91	2.39	2.93	3.41	3.99	4.50	4.93
37	1.89	2.35	2.88	3.36	3.93	4.43	4.86
38	1.87	2.32	2.84	3.31	3.87	4.37	4.79
39	1.85	2.28	2.80	3.26	3.82	4.31	4.73
40	1.83	2.24	2.76	3.22	3.76	4.25	4.66
41	1.81	2.21	2.72	3.17	3.71	4.19	4.60
42	1.79	2.18	2.68	3.13	3.66	4.13	4.54
43	1.77	2.14	2.64	3.09	3.61	4.08	4.49
44	1.75	2.11	2.61	3.05	3.57	4.03	4.43
45	1.73	2.08	2.57	3.01	3.52	3.98	4.38

3.0 RUNOFF :

DRAINAGE BASIN	AREA (AC.)	Q_2 (CFS)	Q_{100} (CFS)
A	0.9	1.9	5.2
B	5.0	10.5	28.7
C	3.1	6.5	17.8
D	2.8	5.9	16.1
E	5.8	12.2	33.3
F	6.6	13.9	37.9
G	2.5	5.3	14.4
H	1.6	3.4	9.2
I	3.1	6.5	17.8

4.0 STREET FLOWS (2 YEARS):

HONEYTRERE HAS $5''$ C & G.

$$X\text{-SLOPE} = \frac{3}{8}'' \text{ PER FT.} = 0.03125$$

$$Z = \frac{1}{0.03125} = 32$$

$$n(\text{ASPH.}) = 0.016$$

$$Z/n = \frac{32}{0.016} = 2,000$$

$$\text{MIN SLOPE (S)} = 0.032$$

$$d = 0.55$$

HALF STREET

$$Q_{\text{CAP}} = 14 \text{ CFS} > Q_2 \text{ FROM F, G, \& H.}$$

SHILOH / BRANDON HAVE $3\frac{5}{8}''$ CURBS:

$$X\text{-SLOPE} = \frac{3}{8}'' \text{ PER FT.} = 0.03125$$

$$Z = \frac{1}{0.03125} = 32$$

$$n(\text{ASPH.}) = 0.016$$

$$Z/n = \frac{32}{0.016} = 2,000$$

$$\text{MIN. SLOPE} = 0.018$$

$$d = 0.30$$

HALF STREET

$$Q_{\text{CAP}} = 6.5 \text{ CFS} > \frac{1}{2} Q_2 \text{ FROM B \& E} \\ > Q_2 \text{ FROM C \& D}$$

O.K.

5.0 STREET FLOW (100 YEAR)

BRANDON AND SAILOR:

WALK GRADE = +0.

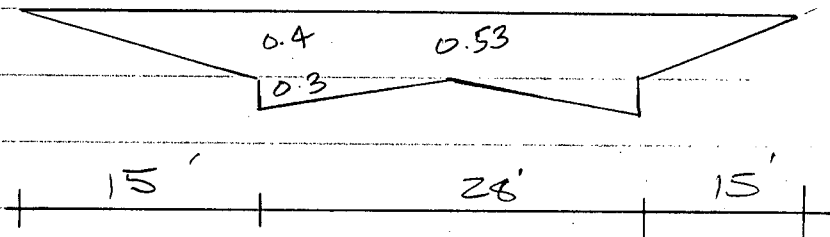

$$n(\text{PARKING}) = 0.03 ; n(\text{GUTTER}) = 0.013$$

$$n(\text{ASPH.}) = 0.016$$

$$n(\text{COMP.}) = \frac{(2 \times 15 \times 0.03 + 2 \times 2.5 \times 0.013 + 28 \times 0.016)}{58}$$

$$= 0.023$$

$$A = \frac{15 \times 0.4 \times 2}{2} + \frac{14 \times 0.3 \times 2}{2} + 0.53 \times 28$$

$$= 25.0 \text{ S.F.}$$

$$P = 58 \text{ FT.}$$

$$R = \frac{25}{58} = 0.43$$

$$S = 0.018$$

$$Q_{\text{CAP}} = 25 \times \frac{1.486}{0.023} \times 0.43^{2/3} \times 0.018^{1/2}$$

$$= 123 \text{ CFS} > \text{ALL } Q_{100} \text{ O.K.}$$

6.0 STREET FLOW (100 YEAR) (HONEY TREE)

WALK GRADE = + 0.4'

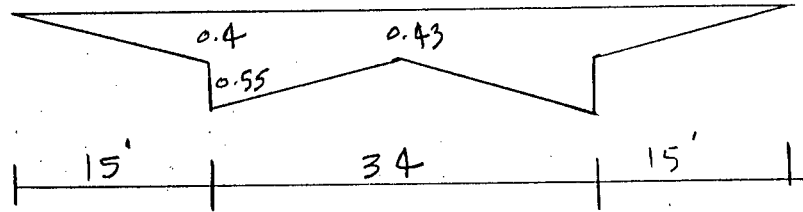

n (PARKING) = 0.03

n (GUTTER) = 0.013

n (ASPHALT) = 0.016

$$n(\text{COMP.}) = \frac{(2 \times 14.5 \times 0.03) + (2 \times 3.05 \times 0.013) + 30 \times 0.016}{65.1}$$

$n(\text{COMP.}) = 0.022$

$$A = \frac{2 \times 0.4 \times 15}{2} + \frac{2 \times 0.52 \times 17}{2} + 0.43 \times 34$$

= 29.5 S.F.

$P = 65.1$

$$R = \frac{A}{P} = \frac{29.5}{65.1} = 0.45$$

$S = 0.0032$ (MIN.)

$$Q_{\text{CAP}} = 29.5 \times \frac{1.486}{0.022} \times 0.45^{2/3} \times 0.0032^{1/2}$$

$Q_{\text{CAP}} = 66.0 \text{ CFS} > \text{ALL } Q_{100} \text{ O.K.}$

NOMOGRAPH FOR FLOW IN TRIANGULAR CHANNELS

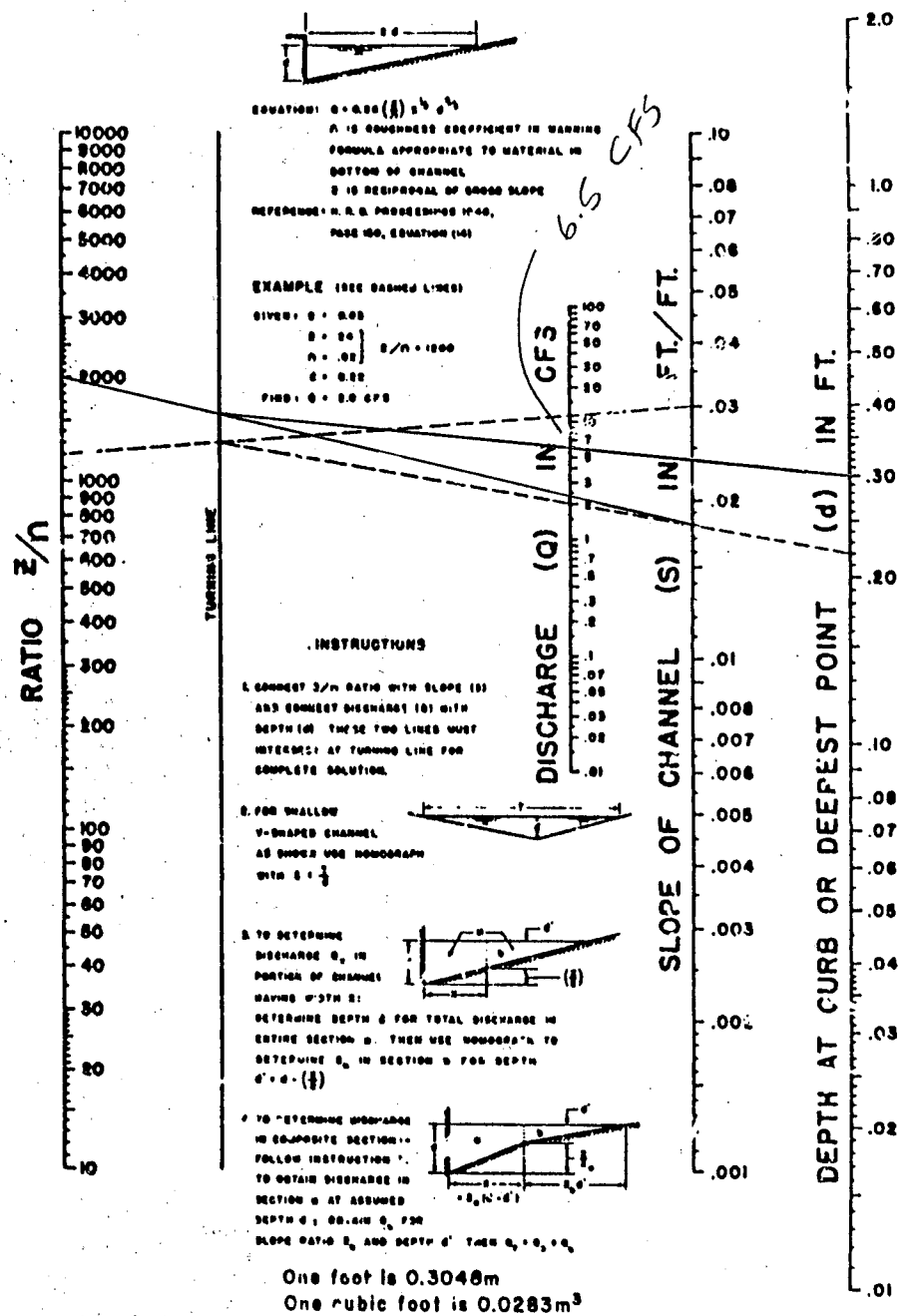

FIG. 5-1 (After FHWA)

HALF STREET @ CAP FOR
 SHILOA / BRANDON 5-10

NOMOGRAPH FOR FLOW IN TRIANGULAR CHANNELS

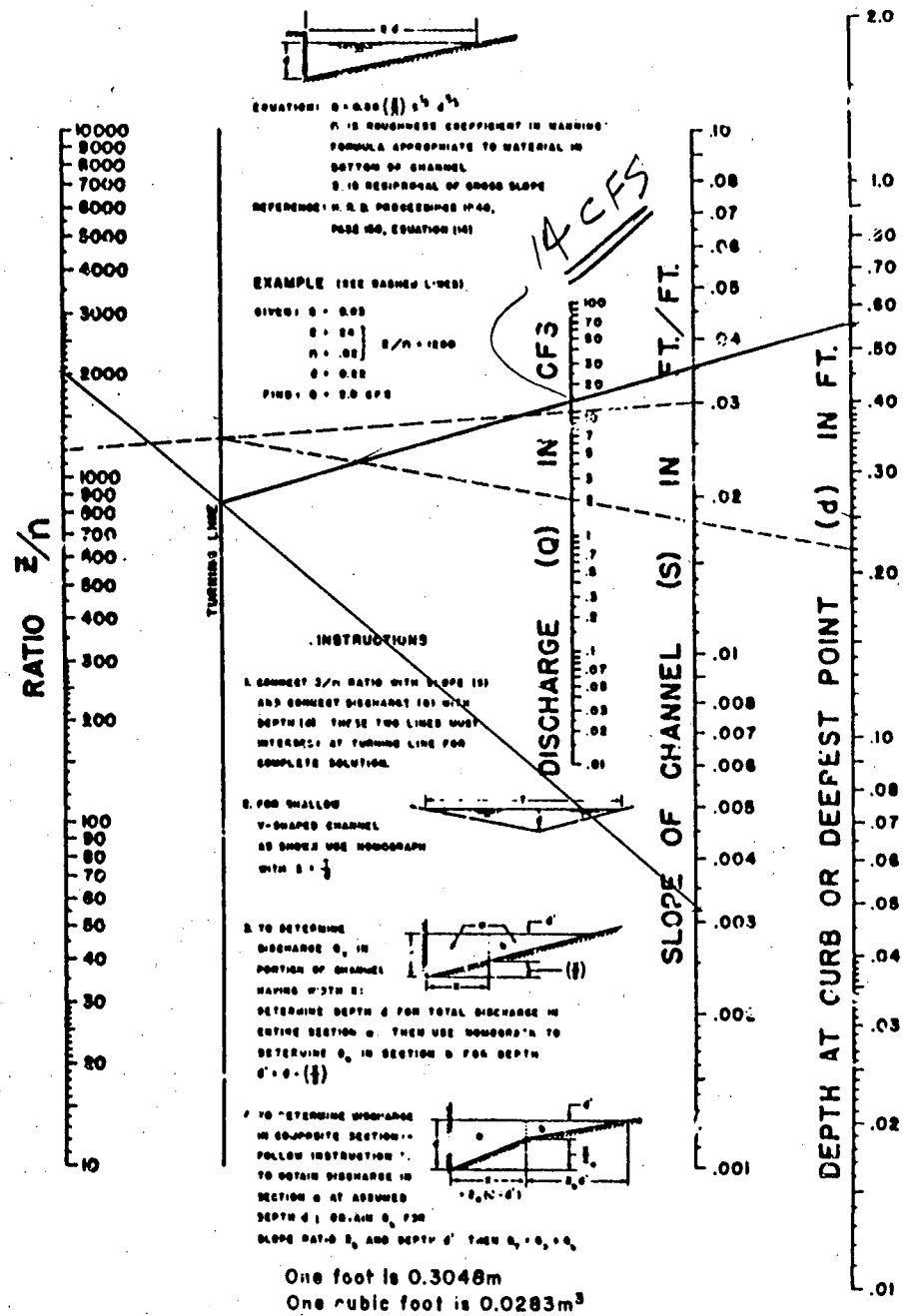

FIG. 5-1 (Adapted FHWA)

Q CAP HALF STREET (HENRY TRER)

7.0 INLET SIZE:

NODE	Q ₂ CFS	EXIST. INLET L	INLET COND.	Q _{MAX} CFS	REMARK
100	1.9	5'	SUMP	11	O.K.
101	10.5	10'	"	22	"
102	6.5	5'	"	11	"
103	5.9	5'	"	11	"
104	12.2	10'	"	22	"
105	13.9	10'	"	22	"
106	8.7	10'	"	22	"

8.0 PIPE SIZE :

FROM NODE	TO NODE	Q ₂ CFS	ΣQ ₂ CFS	EXISTING PIPE	Q _{CAP} CFS	REMARK
100	101	1.9	1.9	15" RCP @ 0.38% SL	4.0	O.K.
101	102	10.5	12.4	24" RCP @ 0.20% SL	10.5	O.K.
102	103	6.5	18.9	30" RCP @ 0.35% SL	25.0	O.K.
103	104	5.9	24.8	36" RCP @ 0.15% SL	28.0	O.K.
104	105	12.2	37.0	42" RCP @ 0.15% SL	42.0	O.K.
105	106	13.9	50.9	42" RCP @ 0.25% SL	54.0	O.K.
106	107	5.3+3.4	59.6	42" RCP @ 0.25% SL	54.0	O.K.

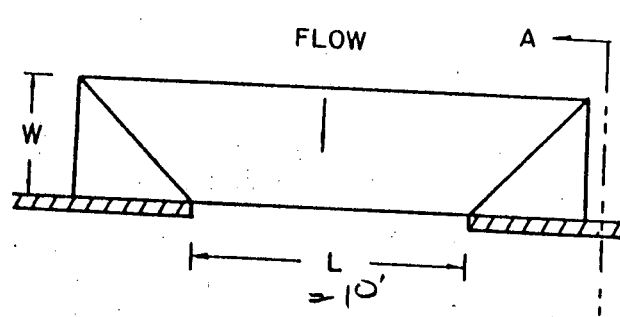
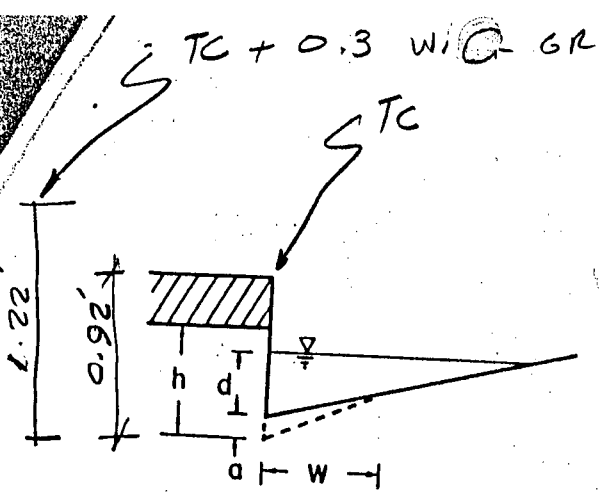

$A = 10' \times 6" = 5.0 \text{ ft}^2$

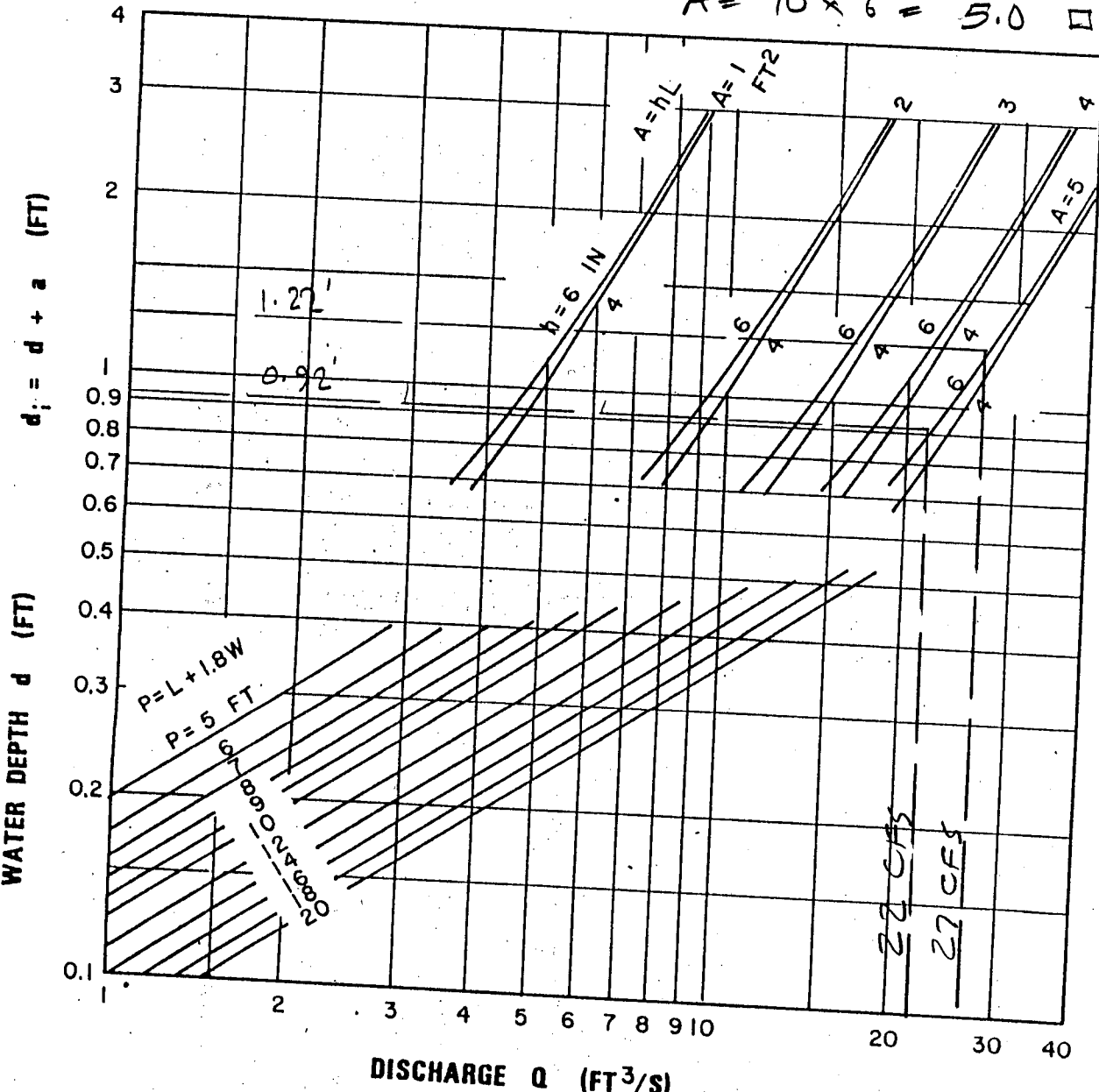
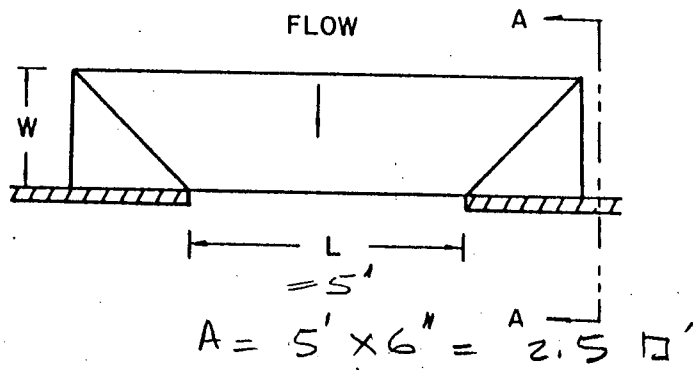
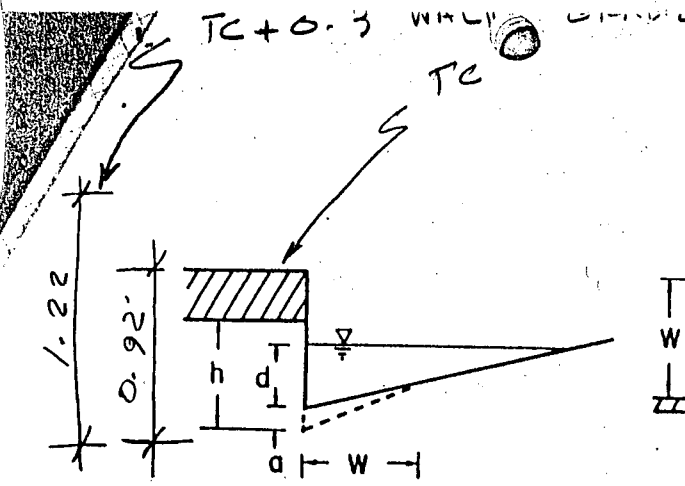

CHART 12. Depressed curb-opening inlet capacity in sump locations.



SECTION A-A

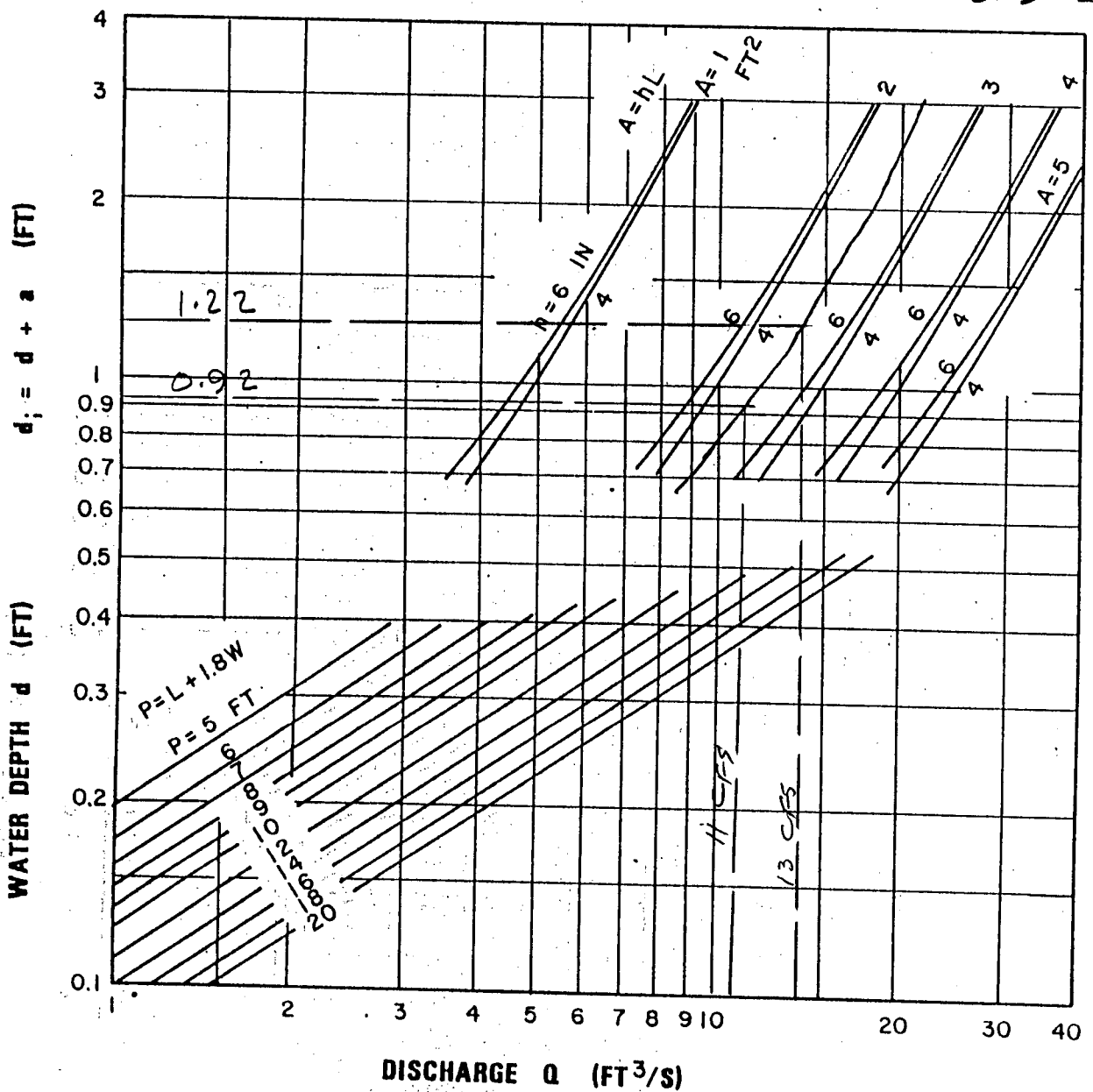

CHART 12. Depressed curb-opening inlet capacity in sump locations.

HARRY



SKETCH PLAN
 NE 1/4,
 SEC. 33-27S-2E
 WICHITA, SEDGWICK COUNTY,
 KANSAS

SCALE:	APPROVED:
DATE:	DRAWN BY:
PROJECT NO.:	CHECKED:
	SHEET NO.:

MUNICIPAL ENGINEERS, P. A.
 518-262-3842