

PROFESSIONAL
ENGINEERING
CONSULTANTS
PROFESSIONAL ASSOCIATION

DRAINAGE PLAN
AND
SUPPORTING CALCULATIONS
FOR
REFLECTION RIDGE 3RD ADDITION
TO WICHITA, SEDGWICK COUNTY, KANSAS

PREPARED BY
PROFESSIONAL ENGINEERING CONSULTANTS, P.A.
ENGINEERS
WICHITA, KANSAS

JANUARY 27, 1989



Date Jan. 25, 1989 Page 1 of 6

Project Reflection Ridge 3rd Addition

Item Drainage Plan SWS

I HYDROLOGY

Use Rational Method.

$Q = C \cdot I \cdot A$

Determine "C" :

<u>Node</u>	<u>Soil Type</u>	<u>Hyd. Grap</u>	<u>Land Use</u>	<u>C₂</u>	<u>C₁₀₀</u>
104	Sa	B	Res; 1/4 Ac	0.44	0.61
103	Sa	B	60% Golf Crs. 40% Res.	0.30	0.49
102	Sa Fb	B	60% Golf Crs. 40% Res.	0.30	0.49
101	Sa Fb	B	30% Res 70% Golf	0.27	0.47
100	(Headwall)				

Determine "I" :

<u>Node</u>	<u>t_c</u>	<u>I₂</u>	<u>I₁₀₀</u>
104	15	3.83	7.37
103	100' @ 0.2fps = 8 500' @ 2fps = 4 12	3.83	7.37
	USE 15		
102	100' @ 0.2fps = 8 1100' @ 2fps = 9 17	3.61	7.00
101	100' @ 0.2fps = 8 300' @ 2fps = 3 11	3.83	7.37
	USE 15		
100	(Headwall)		



Date 1.25.89 Page 2 of 6

Project Reflection Ridge 3rd Add.

Item Drainage Plan SWS

Determine "A"

<u>Node</u>	<u>Plan. Units</u>	<u>Area SF</u>	<u>Area Acres</u>
104	1318	210,880	4.84
103	610	97,600	2.24
102	1260	201,600	4.63
101	530	84,800	1.95
100	(Headwall)		

Determine "Q₂"

<u>Node</u>	<u>C₂</u>	<u>I₂</u>	<u>A</u>	<u>Q₂</u>
104	0.44	3.83	4.84	8.2
103	0.30	3.83	2.24	2.6
102	0.30	3.61	4.63	5.0
101	0.27	3.83	1.95	2.0
100	(Headwall)			

Determine "Q₁₀₀"

<u>Node</u>	<u>C₁₀₀</u>	<u>I₁₀₀</u>	<u>A</u>	<u>Q₁₀₀</u>
104	0.61	7.37	4.84	21.8
103	0.49	7.37	2.24	8.1
102	0.49	7.00	4.63	15.9
101	0.47	7.37	1.95	6.8
100	(Headwall)			

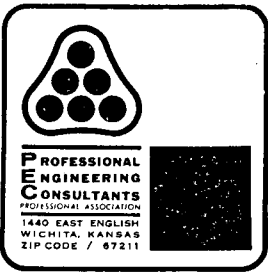

Date 1.27.89 Page 3 of 6

Project Reflection Ridge 3rd Add.

Item Drainage Plan SWS

II INLET SIZING

<u>Node</u>	<u>Q</u>	<u>Design Freq.</u>	<u>Inlet Type</u>	<u>Length</u>	<u>Q_{max}</u>
104	21.8	100	1A	10'	26
103	26	2	Catch Basin	2'x2'*	-
102	5.0	2	"	2'x2'*	-
101	2.0	2	"	2'x2'*	-
100	(Headwell)	-			

* may be larger (2'x4') to accommodate the pipes entering or exiting C.B.

100 j, 1354.5000 100 3 5 4

110 t, reflection ridge 3rd addition

120 t, drainage plan

130 t, storm water sewer system no. 1 analysis

140 i, 104 0.61 4.84 0.00 0.00 21.00 15.00 1359.00

150 i, 103 0.30 2.24 0.00 0.00 2.60 15.00 1356.00

160 i, 102 0.30 4.63 0.00 0.00 5.00 17.00 1355.00

170 i, 101 0.27 1.95 0.00 0.00 2.00 15.00 1356.00

180 m, 100 1354.50

190 p, 104 103 170.00 30 0.013 95.00 0.00

200 p, 103 102 120.00 30 0.013 70.00 0.00

210 p, 102 101 270.00 30 0.013 20.00 0.00

220 p, 101 100 40.00 30 0.013 0.00 0.00

230 e

5/6

Date: 01-27-1989
Time: 09:39:41

Input File: rr3

reflection ridge 3rd addition
drainage plan
storm water sewer system no. 1 analysis

Storm Frequency = 100-Year

*** HYDROLOGY ***

Tributary Area							Hydrology Summation					Conduit Data					
Node to Node	C	Area (Ac)	Slope (%)	Length (Ft)	TC(Ø) (Min)	I(Ø) (In/Hr)	Q(Ø) (CFS)	TC (Min)	I (In/Hr)	Q (CFS)	Sum Q (CFS)	Size	Velocity (Ft/Sec)	Length (Ft)	TT (Min)	TT+TC (Min)	
104	103	0.61	4.84	0.00	0.0	15.00	8.97	21.00	15.00	8.97	21.00	21.00	30"	4.44	170.00	0.64	15.64
103	102	0.30	2.24	0.00	0.0	15.00	8.97	2.60	15.64	8.83	2.56	24.36	30"	4.96	120.00	0.40	16.04
102	101	0.30	4.63	0.00	0.0	17.00	8.55	5.00	16.04	8.74	4.72	29.08	30"	5.92	270.00	0.76	16.80
101	100	0.27	1.95	0.00	0.0	15.00	8.97	2.00	16.80	8.59	1.91	30.99	30"	6.31	40.00	0.11	16.91

Q₁₀₀

6/6

Date: 01-27-1989
Time: 09:39:41

Input File: rr3

reflection ridge 3rd addition
drainage plan
storm water sewer system no. 1 analysis

Storm Frequency = 100-Year

*** HYDRAULICS ***

```

*****
Node      Hyd-Slope  Friction  Bend      Transition  Manhole  Deflection  Junction  Total      Hyd-El     Desired  Diff.
      (Ft/Ft)   (Ft)     (Ft)      (Ft)        (Ft)     (Ft)       (Ft)     (Ft)     Elevation Elevation (Ft)
*****
104      0.00282    0.4802   0.0000    0.0000     0.0000   0.0000    0.0000    0.4802  1358.0599  1359.0000  0.94
103      0.00353    0.4232   0.0000    0.0076     0.0000   0.1634    0.1684    0.7626  1357.5797  1356.0000  -1.58
102      0.00503    1.3568   0.0000    0.0162     0.0000   0.1414    0.3469    1.8613  1356.8171  1355.0000  -1.82
101      0.00571    0.2283   0.0000    0.0074     0.0000   0.0448    0.1753    0.4558  1354.9558  1356.0000  1.04
100      0.00000    0.0000   0.0000    0.0000     0.0000   0.0000    0.0000    0.0000  1354.5000  1354.5000  0.00
*****

```

top pipe @ lake
(30" above
static pool)

in golf course (OK)

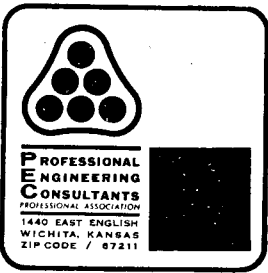

Date 1.27.89 Page 1 of 2

Project Reflection Ridge 3rd Add.

Item Drainage Plan Street Flow

<u>Node</u>	<u>2-YR</u> <u>Q₂</u>	<u>Distribution</u>	<u>street</u> <u>slope</u>	<u>d</u>	<u>d_{max}</u>	<u>Comment</u>
104	8.2	50% N/E = 4.1 50% S/W = 4.1	0.5% 0.5%	0.33' 0.33'	0.3' 0.3'	OK OK

<u>Location</u>	<u>100-YR</u> <u>Contrib. Areas</u>	<u>Q₁₀₀</u>	<u>Q_{pipe}</u>	<u>Q_{street}</u>	<u>street slope</u>	<u>Q_{max}</u>	<u>Comment</u>
Approaching Node 104	100% 104	21.8	0.0	21.8	0.5%	28.6	OK Roll Cb. (see page 2) w/ 0.3' wk. grade

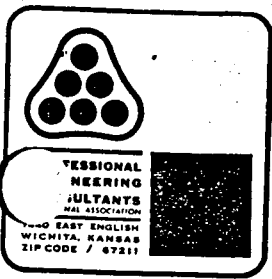

Date Jan. 27, 1989 Page 2 of 2

Project Reflection Ridge 3rd Add

Item Drainage Plan Street Flow

Determine capacities of Roll-curb streets w/
various Walk Grades for 100-year storm analysis
(58' R-O-W)

0.3'
Walk Grade

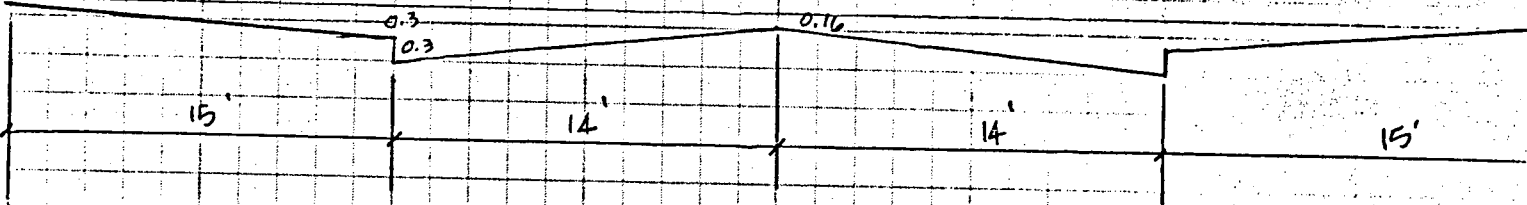

$$n = \frac{(2 \times 14.5 \times 0.03) + (2 \times 2.8 \times 0.013) + (2 \times 12 \times 0.016)}{58.6}$$

$$= \frac{(0.87) + (0.0728) + (0.384)}{58.6} = \frac{1.3268}{58.6} = 0.0226$$

$$A = (2 \times \frac{1}{2} \times 15 \times 0.3) + (28 \times 0.016) + (2 \times \frac{1}{2} \times 14 \times 0.44)$$

$$= 4.5 + 4.48 + 6.16$$

$$= 15.14 \text{ SF}$$

$$p = 58.6$$

$$R = A/p = 15.14/58.6 = 0.258362$$

$$R^{2/3} = 0.40565$$

$$Q = \frac{1.486}{n} A R^{2/3} s^{1/2}$$

$$= \frac{1.486}{0.0226} \times 15.14 \times 0.40565 \times s^{1/2}$$

$$Q = 403.82 \sqrt{s}$$

EXHIBIT NO. 1

SOIL LEGEND

<u>SYMBOL</u>	<u>HYDROLOGIC GROUP</u>	<u>NAME</u>
Aa	B	Albion-Shellabarger sandy loams, 1 to 4 percent slopes
Ab	B	Albion and Shellabarger sandy loams, 7 to 15 percent slopes
Ba	C	Blanket silt loam, 0 to 1 percent slopes
Bb	C	Blanket silt loam, 1 to 3 percent slopes
Ca	B	Canadian fine sandy loam
Cb	B	Canadian-Waldeck fine sandy loams
Cc	D	Carwile fine sandy loam
Cd	B	Clark-Ost clay loams, 1 to 4 percent slopes
Ce	C	Cline silty clay, 3 to 6 percent slopes
Ea	B	Elandco silt loam
Eb	B	Elandco silt loam, occasionally flooded
Ec	B	Elandco silt loam, frequently flooded
Fa	B	Farnum loam, 0 to 1 percent slopes
Fb	B	Farnum loam, 1 to 3 percent slopes
Fc	B	Farnum loam, sandy substratum, 0 to 1 percent slopes
Ga	D	Goessel silty clay, 0 to 1 percent slopes
Gb	D	Goessel silty clay, 1 to 2 percent slopes
Ia	D	Irwin silty clay loam, 1 to 3 percent slopes
Ib	D	Irwin silty clay loam, 3 to 6 percent slopes
Ic	D	Irwin silty clay loam, 2 to 6 percent slopes, eroded
La	C	Lesho loam
Lb	A	Lincoln soils
Ma	B	Milan loam, 1 to 3 percent slopes
Mb	B	Milan form, 3 to 6 percent slopes
Mc	B	Milan clay loam, 2 to 6 percent slopes, eroded
Na	B	Naron fine sandy loam
Oc	D	Owens clay loam, 1 to 3 percent slopes
Od	D	Owens-Rock outcrop complex, 3 to 10 percent slopes
Pa		Pits
Pb	D	Plevna fine sandy loam
Pc	A	Pratt loamy fine sand, undulating
Pd	A	Pratt-Tivoli complex, rolling
Ra	D	Renfrow silty clay loam, 1 to 3 percent slopes
Rb	D	Renfrow silty clay loam, 3 to 6 percent slopes
Rc	D	Renfrow-Owens clay loams, 1 to 4 percent slopes
Rd	D	Rosehill silty clay, 1 to 3 percent slopes
Sa	B	Shellabarger sandy loam, 1 to 3 percent slopes
Sb	B	Shellabarger sandy loam, 3 to 6 percent slopes
Sc	B	Shellabarger sandy loam, 3 to 6 percent slopes, eroded
Ta	D	Tabler silty clay loam
Tb	D	Tabler-Drummond complex
Ua	B	Urban land-Canadian complex
Ub	B	Urban land-Elandco complex
Uc	B	Urban land-Farnum complex, 0 to 3 percent slopes
Ud	D	Urban land-Irwin complex, 1 to 3 percent slopes
Ue	D	Urban land-Tabler complex
Va	B	Vanoss silt loam, 0 to 1 percent slopes
Vb	B	Vanoss silt loam, 1 to 3 percent slopes
Vc	B	Vanoss silt loam, 3 to 6 percent slopes
Vd	B	Vanoss silt loam, 3 to 6 percent slopes, eroded
Ve	D	Vernon sandy loam, 1 to 3 percent slopes
Vf	D	Vernon sandy loam, 3 to 6 percent slopes
Wa	C	Waldeck sandy loam
Wb	D	Waurika silt loam

ATTACHMENT D

DRAINAGE CRITERIA

CITY OF WICHITA, KANSAS

RECOMMENDED RUNOFF COEFFICIENTS FOR RATIONAL METHOD
AND PERCENT IMPERVIOUS FOR UNIT HYDROGRAPH METHOD

Land Use or Surface Characteristics	Percent Impervious	Frequency			
		<u>2</u>	<u>5</u>	<u>10</u>	<u>100</u>
1. Business:					
Downtown Areas	95	0.84	0.85	0.87	0.91
Neighborhood Areas	70	0.68	0.69	0.73	0.80
2. Residential:					
<u>Single Family (Soil Group D)</u>					
1/8 Acre	50	0.57	0.61	0.66	0.79
1/4 Acre	38	0.50	0.54	0.62	0.76
1/3 Acre	30	0.46	0.50	0.59	0.73
1/2 Acre	25	0.42	0.48	0.56	0.72
3/4 Acre	22	0.42	0.46	0.55	0.71
1 Acre	20	0.41	0.45	0.54	0.71
<u>Multi-Family (Soil Group D)</u>					
Multi-Unit (detached)	60	0.62	0.66	0.72	0.82
Multi-Unit (attached)	65	0.64	0.68	0.73	0.83
Apartments	75	0.70	0.73	0.79	0.86
<u>Single Family (Soil Group C)</u>					
1/8 Acre	50	0.55	0.58	0.64	0.73
1/4 Acre	38	0.48	0.51	0.57	0.68
1/3 Acre	30	0.43	0.46	0.53	0.65
1/2 Acre	25	0.40	0.43	0.50	0.63
3/4 Acre	22	0.39	0.42	0.49	0.62
1 Acre	20	0.37	0.40	0.48	0.61
<u>Multi-Family (Soil Group C)</u>					
Multi-Unit (detached)	60	0.60	0.63	0.69	0.77
Multi-Unit (attached)	65	0.63	0.66	0.71	0.79
Apartments	75	0.68	0.72	0.77	0.83
<u>Single-Family (Soil Group B)</u>					
1/8 Acre	50	0.52	0.54	0.59	0.67
1/4 Acre	38	0.44	0.46	0.52	0.61
1/3 Acre	30	0.39	0.41	0.47	0.57
1/2 Acre	25	0.36	0.38	0.44	0.54
3/4 Acre	22	0.34	0.36	0.42	0.52
1 Acre	20	0.33	0.35	0.40	0.51
<u>Multi-Family (Soil Group B)</u>					
Multi-Unit (detached)	60	0.58	0.60	0.65	0.72
Multi-Unit (attached)	65	0.61	0.64	0.68	0.75
Apartments	75	0.67	0.70	0.74	0.80

Land Use or Surface Characteristics	Percent Impervious	Frequency			
		<u>2</u>	<u>5</u>	<u>10</u>	<u>100</u>
<u>Single Family (Soil Group A)</u>					
1/3 Acre	50	0.47	0.50	0.54	0.60
1/4 Acre	38	0.39	0.41	0.45	0.52
1/3 Acre	30	0.33	0.35	0.39	0.47
1/2 Acre	25	0.30	0.31	0.35	0.44
3/4 Acre	22	0.28	0.29	0.33	0.42
1 Acre	20	0.26	0.28	0.32	0.40
<u>Multi-Family (Soil Group A)</u>					
Multi-Unit (detached)	60	0.55	0.57	0.61	0.67
Multi-Unit (attached)	65	0.58	0.60	0.64	0.70
Apartments	75	0.65	0.68	0.72	0.77
3. Industrial:					
Light Areas	70	0.68	0.69	0.73	0.80
Heavy Areas	80	0.74	0.76	0.79	0.84
4. Playgrounds:					
	15	0.33	0.35	0.42	0.55
5. Schools:					
	40	0.49	0.51	0.56	0.66
6. Railroad Yard Areas:					
	30	0.43	0.45	0.50	0.62
7. Undeveloped Urban Areas: Offsite Flow Analysis (when land use not defined)					
	45	0.52	0.54	0.59	0.68
8. Streets:					
Paved	99	0.87	0.88	0.90	0.93
Gravel	00	0.24	0.26	0.33	0.48
9. Drive, Parking Lots and Walks:					
	96	0.87	0.87	0.88	0.89
10. Roofs:					
	90	0.80	0.85	0.90	0.93
11. Urban Lawn Areas (See Note No. 1 below):					
<u>Soil Group A</u>					
Slope less than 1%	00	0.08	0.09	0.13	0.23
Slope 1% to 4%	00	0.12	0.13	0.17	0.27
Slope more than 4%	00	0.16	0.17	0.21	0.31
<u>Soil Group B</u>					
Slope less than 1%	00	0.16	0.18	0.24	0.37
Slope 1% to 4%	00	0.20	0.22	0.28	0.41
Slope more than 4%	00	0.24	0.26	0.32	0.45
<u>Soil Group C</u>					
Slope less than 1%	00	0.24	0.27	0.35	0.51
Slope 1% to 4%	00	0.26	0.29	0.37	0.53
Slope more than 4%	00	0.28	0.31	0.39	0.55

Land Use or
Surface Characteristics

Percent
Impervious

Frequency

Soil Group D

		<u>2</u>	<u>5</u>	<u>10</u>	<u>100</u>
Slope less than 1%	00	0.28	0.33	0.43	0.63
Slope 1% to 4%	00	0.30	0.35	0.45	0.65
Slope more than 4%	00	0.32	0.37	0.47	0.67

Note No. 1: Coefficients shown in the above table are for pervious open space areas with thick turf which includes pervious areas in parks and cemeteries. Coefficients shown above must be increased 0.02 for use with agricultural pasture areas. Coefficients shown above must be reduced by 0.04 for use with agricultural cultivated areas. Group A soils are well-drained, coarse textured sands with high infiltration rates. Group B soils are moderately well-drained, moderately coarse textured soils with moderate infiltration rates. Group C soils are moderately poor-drained, moderately fine textured soils with slow infiltration rates. Group D soils are poor-drained, fine textured soils with very slow infiltration rates.

GENERAL NOTE: These Rational Formula Coefficients may not be valid for basins 320 acres or larger.

ATTACHMENT E

DRAINAGE CRITERIA

CITY OF WICHITA, KANSAS

AVERAGE OVERLAND FLOW VELOCITY FOR USE WITH URBANIZED AREAS

Surface Type	VELOCITY IN FEET/SECOND FOR SLOPES IN PERCENT SHOWN																			
	0.1	0.2	0.3	0.4	0.5	0.6	0.7	0.8	0.9	1.0	2.0	3.0	4.0	5.0	6.0	7.0	8.0	9.0	10.0	20.0
Forest with Heavy Ground Litter or Meadow	0.03	0.04	0.06	0.07	0.08	0.09	0.10	0.11	0.12	0.13	0.16	0.21	0.28	0.33	0.39	0.46	0.53	0.60	0.72	1.10
Fallow or Minimum Tillage Cultivation	0.06	0.08	0.10	0.12	0.13	0.14	0.16	0.17	0.18	0.19	0.29	0.40	0.51	0.66	0.78	0.91	1.05	1.20	1.44	2.10
Short Grass Pasture or Lawns	0.09	0.13	0.15	0.18	0.20	0.21	0.23	0.25	0.26	0.28	0.45	0.60	0.77	0.96	1.17	1.33	1.50	1.68	1.98	3.20
Almost Bare Ground	0.16	0.22	0.28	0.31	0.35	0.38	0.41	0.44	0.46	0.49	0.70	0.85	1.05	1.26	1.50	1.75	2.03	2.32	2.79	4.10
Grassed Waterway	0.35	0.48	0.58	0.67	0.77	0.84	0.91	0.98	1.05	1.12	1.54	1.82	2.10	2.38	2.78	3.20	3.66	4.14	4.56	7.00
Paved Areas (Sheet Flow) or Shallow Gutter Flow	0.44	0.62	0.77	0.91	1.05	1.12	1.19	1.26	1.33	1.40	2.00	2.55	3.20	3.83	4.41	5.04	5.70	6.00	6.20	9.00

April 15, 1986

ATTACHMENT A
DRAINAGE CRITERIA MANUAL

CITY OF WICHITA, KANSAS

RAINFALL INTENSITY TABLE FOR SEDGWICK COUNTY, KANSAS

The following tabulation contains rainfall intensity in inches per hour as derived from ESSA Weather Bureau Technical Paper 40 Modified to NWS Hydro-35, 1977 During First Hour

DURATION IN MINUTES	RETURN PERIODS OF						
	1-YR	2-YR	5-YR	10-YR	25-YR	50-YR	100-YR
5	4.18	5.57	6.53	7.41	8.52	9.48	10.32
6	3.99	5.32	6.25	7.09	8.16	9.09	9.89
7	3.81	5.09	5.99	6.81	7.84	8.74	9.50
8	3.66	4.89	5.75	6.55	7.55	8.42	9.15
9	3.52	4.70	5.54	6.31	7.28	8.13	8.83
10	3.39	4.52	5.34	6.09	7.04	7.86	8.54
11	3.27	4.36	5.16	5.89	6.81	7.61	8.27
12	3.18	4.21	4.99	5.71	6.60	7.38	8.02
13	3.05	4.08	4.84	5.53	6.41	7.17	7.79
14	2.96	3.95	4.69	5.37	6.23	6.97	7.57
15	2.87	3.83	4.56	5.22	6.06	6.78	7.37
16	2.78	3.72	4.43	5.08	5.90	6.60	7.18
17	2.71	3.61	4.31	4.95	5.75	6.44	7.00
18	2.63	3.51	4.20	4.83	5.61	6.29	6.84
19	2.56	3.42	4.10	4.71	5.47	6.14	6.68
20	2.50	3.33	4.00	4.60	5.35	6.00	6.53
21	2.44	3.25	3.90	4.50	5.23	5.87	6.39
22	2.38	3.17	3.81	4.40	5.12	5.75	6.26
23	2.32	3.10	3.73	4.31	5.01	5.63	6.13
24	2.27	3.03	3.65	4.22	4.91	5.52	6.01
25	2.22	2.96	3.57	4.13	4.81	5.41	5.90
26	2.20	2.90	3.50	4.05	4.72	5.31	5.79
27	2.16	2.84	3.43	3.98	4.63	5.21	5.69
28	2.14	2.78	3.37	3.90	4.55	5.12	5.59
29	2.11	2.72	3.30	3.83	4.47	5.03	5.49
30	2.08	2.67	3.24	3.76	4.39	4.94	5.40
31	2.05	2.62	3.19	3.70	4.32	4.86	5.32
32	2.02	2.57	3.10	3.63	4.25	4.79	5.22
33	1.99	2.52	3.05	3.57	4.18	4.71	5.14
34	1.96	2.48	3.01	3.51	4.11	4.63	5.07
35	1.93	2.44	2.98	3.46	4.05	4.56	5.00
36	1.91	2.39	2.93	3.41	3.99	4.50	4.93
37	1.89	2.35	2.88	3.36	3.93	4.43	4.86
38	1.87	2.32	2.84	3.31	3.87	4.37	4.79
39	1.85	2.28	2.80	3.26	3.82	4.31	4.73
40	1.83	2.24	2.76	3.22	3.76	4.25	4.66
41	1.81	2.21	2.72	3.17	3.71	4.19	4.60
42	1.79	2.18	2.68	3.13	3.66	4.13	4.54
43	1.77	2.14	2.64	3.09	3.61	4.08	4.49
44	1.75	2.11	2.61	3.05	3.57	4.03	4.43
45	1.73	2.08	2.57	3.01	3.52	3.98	4.38

ATTACHMENT A CONTINUED
Page 2

<u>DURATION IN MINUTES</u>	<u>RETURN PERIODS OF</u>						
	<u>1-YR</u>	<u>2-YR</u>	<u>5-YR</u>	<u>10-YR</u>	<u>25-YR</u>	<u>50-YR</u>	<u>100-YR</u>
46	1.70	2.05	2.54	2.97	3.48	3.93	4.33
47	1.67	2.02	2.50	2.93	3.44	3.88	4.28
48	1.66	2.00	2.47	2.90	3.39	3.84	4.23
49	1.64	1.97	2.44	2.86	3.35	3.79	4.18
50	1.61	1.95	2.41	2.83	3.32	3.75	4.13
51	1.59	1.92	2.38	2.79	3.28	3.71	4.09
52	1.56	1.89	2.35	2.76	3.24	3.67	4.05
53	1.54	1.86	2.33	2.73	3.20	3.63	4.00
54	1.52	1.84	2.30	2.70	3.17	3.59	3.96
55	1.50	1.81	2.27	2.67	3.14	3.55	3.92
56	1.47	1.79	2.25	2.64	3.10	3.51	3.88
57	1.45	1.76	2.22	2.61	3.07	3.48	3.84
58	1.43	1.74	2.20	2.59	3.04	3.44	3.81
59	1.42	1.72	2.18	2.56	3.01	3.41	3.77
60	1.40	1.69	2.15	2.53	2.98	3.37	3.73
61	1.38	1.67	2.13	2.51	2.95	3.34	3.70
62	1.36	1.65	2.11	2.48	2.92	3.31	3.67
63	1.34	1.63	2.09	2.46	2.89	3.28	3.63
64	1.33	1.61	2.07	2.44	2.86	3.25	3.60
65	1.31	1.59	2.05	2.41	2.84	3.22	3.57
66	1.30	1.57	2.03	2.39	2.81	3.19	3.54
67	1.28	1.56	2.01	2.37	2.79	3.16	3.51
68	1.26	1.54	1.99	2.35	2.76	3.13	3.48
69	1.25	1.52	1.97	2.33	2.74	3.10	3.45
70	1.24	1.50	1.95	2.31	2.71	3.08	3.42
71	1.22	1.49	1.93	2.28	2.69	3.05	3.39
72	1.21	1.47	1.92	2.26	2.67	3.02	3.36
73	1.20	1.46	1.90	2.25	2.64	3.00	3.34
74	1.18	1.44	1.88	2.23	2.63	2.98	3.31
75	1.17	1.43	1.86	2.21	2.61	2.95	3.29
76	1.16	1.41	1.85	2.19	2.58	2.93	3.26
77	1.15	1.40	1.83	2.17	2.55	2.90	3.24
78	1.13	1.38	1.82	2.15	2.53	2.88	3.22
79	1.12	1.37	1.80	2.14	2.50	2.86	3.19
80	1.11	1.36	1.79	2.12	2.48	2.84	3.16
81	1.10	1.34	1.77	2.10	2.46	2.82	3.13
82	1.09	1.33	1.76	2.08	2.43	2.79	3.10
83	1.08	1.32	1.74	2.06	2.41	2.76	3.07
84	1.07	1.31	1.73	2.04	2.39	2.74	3.04
85	1.06	1.30	1.72	2.02	2.37	2.71	3.01
86	1.05	1.28	1.70	2.00	2.34	2.69	2.99
87	1.04	1.27	1.69	1.99	2.32	2.66	2.96
88	1.03	1.26	1.68	1.97	2.30	2.64	2.93
89	1.02	1.25	1.68	1.95	2.28	2.62	2.91
90	1.01	1.24	1.66	1.93	2.26	2.59	2.88

ATTACHMENT A CONTINUED
Page 3

<u>DURATION IN MINUTES</u>	<u>RETURN PERIODS OF</u>						
	<u>1-YR</u>	<u>2-YR</u>	<u>5-YR</u>	<u>10-YR</u>	<u>25-YR</u>	<u>50-YR</u>	<u>100-YR</u>
91	1.00	1.23	1.65	1.92	2.24	2.57	2.86
92	1.00	1.22	1.63	1.90	2.22	2.55	2.83
93	0.99	1.21	1.62	1.89	2.20	2.53	2.81
94	0.98	1.20	1.61	1.87	2.19	2.51	2.79
95	0.97	1.19	1.59	1.85	2.17	2.49	2.76
96	0.96	1.18	1.58	1.84	2.15	2.46	2.74
97	0.96	1.17	1.57	1.82	2.13	2.44	2.72
98	0.95	1.16	1.56	1.81	2.12	2.42	2.70
99	0.94	1.15	1.54	1.80	2.10	2.41	2.67
100	0.93	1.14	1.53	1.78	2.08	2.39	2.65
101	0.93	1.13	1.52	1.77	2.07	2.39	2.65
102	0.92	1.13	1.51	1.75	2.05	2.35	2.61
103	0.91	1.12	1.50	1.74	2.04	2.33	2.59
104	0.90	1.11	1.49	1.73	2.02	2.31	2.57
105	0.90	1.10	1.47	1.72	2.01	2.30	2.55
106	0.89	1.09	1.46	1.70	1.99	2.28	2.54
107	0.88	1.09	1.45	1.69	1.98	2.26	2.52
108	0.88	1.08	1.44	1.68	1.96	2.25	2.50
109	0.87	1.07	1.43	1.67	1.95	2.23	2.48
110	0.87	1.06	1.42	1.65	1.93	2.21	2.46
111	0.86	1.06	1.41	1.64	1.92	2.20	2.45
112	0.85	1.05	1.40	1.63	1.91	2.18	2.43
113	0.85	1.04	1.39	1.62	1.89	2.17	2.41
114	0.84	1.03	1.38	1.61	1.88	2.15	2.40
115	0.84	1.03	1.37	1.60	1.87	2.14	2.38
116	0.83	1.02	1.36	1.59	1.86	2.12	2.36
117	0.82	1.01	1.36	1.58	1.84	2.11	2.35
118	0.82	1.01	1.35	1.57	1.83	2.09	2.33
119	0.81	1.00	1.34	1.56	1.82	2.08	2.32
120	0.81	0.99	1.33	1.55	1.81	2.07	2.30

<u>DURATION IN HOURS</u>	<u>RETURN PERIODS OF</u>						
	<u>1-YR</u>	<u>2-YR</u>	<u>5-YR</u>	<u>10-YR</u>	<u>25-YR</u>	<u>50-YR</u>	<u>100-YR</u>
2	0.81	0.99	1.33	1.55	1.81	2.07	2.30
3	0.59	0.72	0.97	1.13	1.32	1.51	1.68
4	0.47	0.58	0.78	0.91	1.06	1.21	1.35
5	0.40	0.49	0.66	0.77	0.89	1.02	1.14
6	0.35	0.42	0.57	0.67	0.78	0.89	0.99
8	0.28	0.34	0.46	0.53	0.62	0.71	0.79
10	0.23	0.29	0.39	0.45	0.52	0.60	0.67
12	0.20	0.25	0.33	0.39	0.45	0.52	0.58
18	0.15	0.18	0.24	0.28	0.33	0.38	0.42
24	0.12	0.15	0.20	0.23	0.27	0.31	0.34

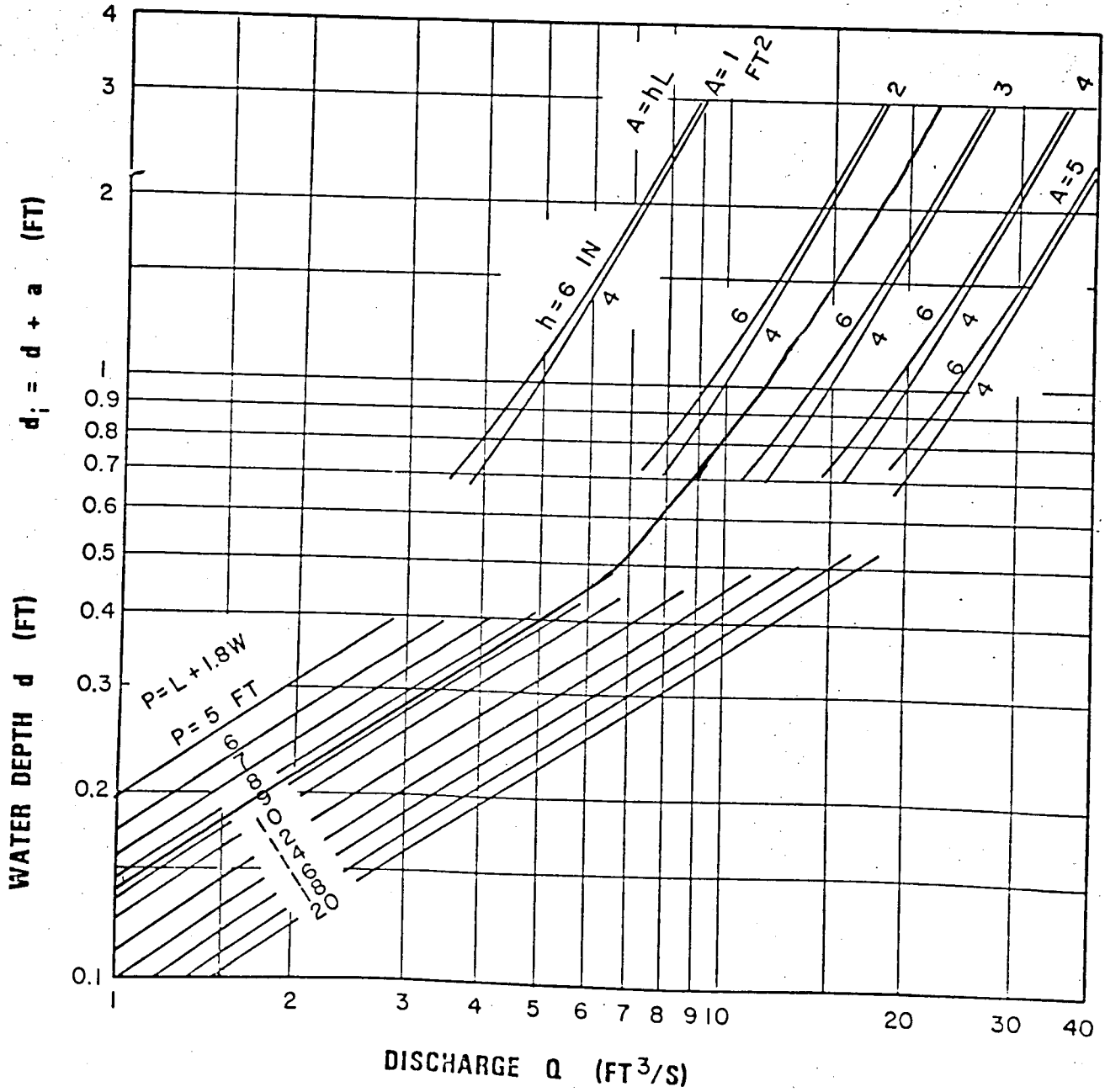
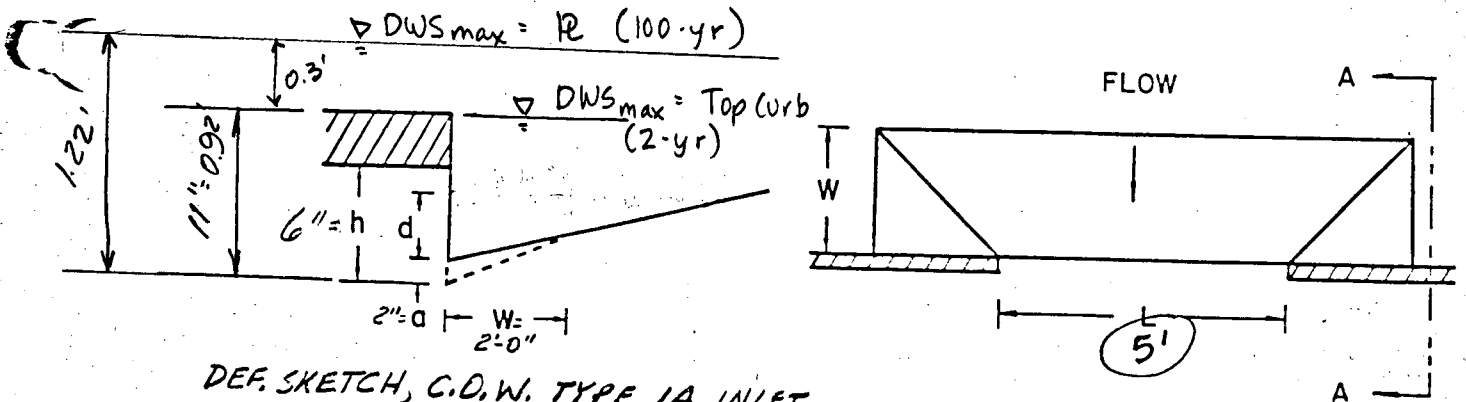

FROM: HEC-12, DRAINAGE OF HIGHWAY PAVEMENTS, F.H.W.A., MAR, 1974

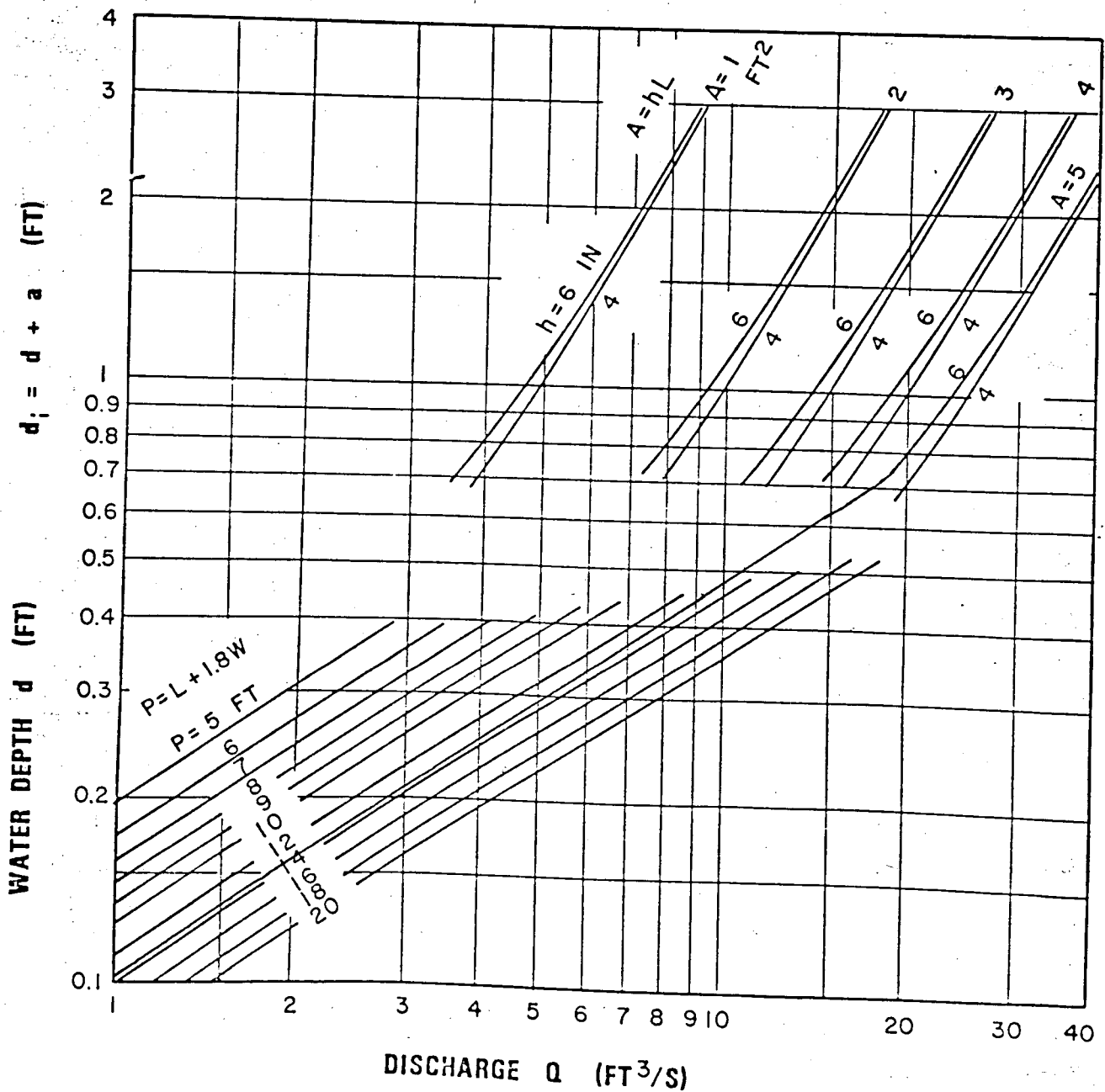
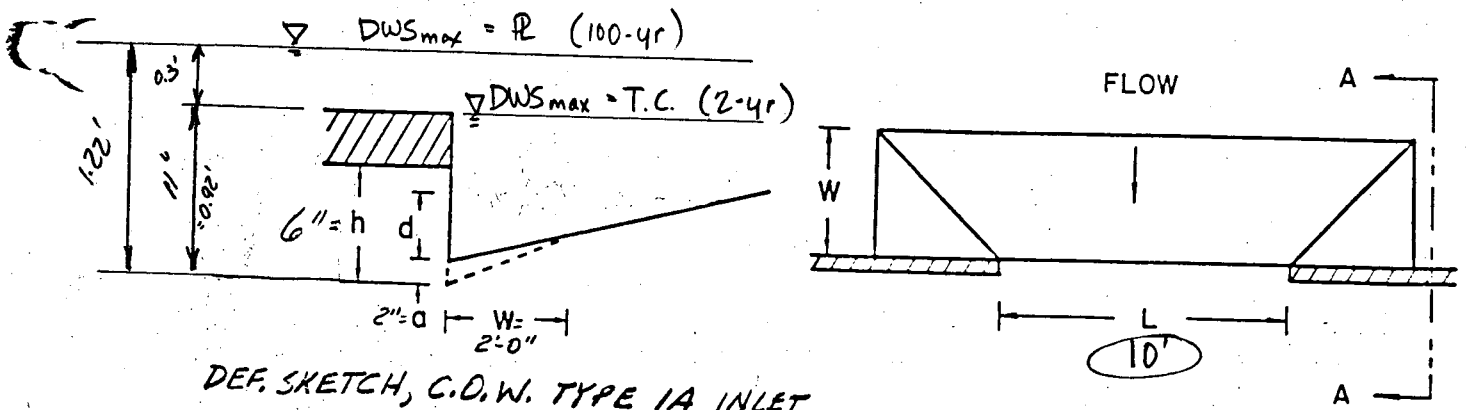

CHART 12. Depressed curb-opening inlet capacity in sump locations.

FROM: HEC-12, DRAINAGE OF HIGHWAY PAVEMENTS, F.H.W.A., MAR., 1974

Reflection Ridge 3rd Add. - Drainage Plan

X-slope = $\frac{3}{8}$ "/ft = 0.03125 ft/ft

$n = 0.016$

$z = 1/x \text{ slope} = 1/0.03125 = 32$

$z/n = 32/0.016 = 2000$

