

Savanna at Castle Rock Ranch 10th Addition
Sedgwick County, Kansas

3/09/04

Savanna at Castle Rock Ranch 10th Addition is a 15 acre, single family, residential development east of Wichita in Sedgwick County, Kansas. The 15 lot development consists of streets, storm sewer and detention ponds. This report contains a drawing of the drainage plan, supporting calculations and data for the Savanna at Castle Rock Ranch 10th Addition Drainage Plan.

Hydrology

The proposed plat lies in the NE 1/4, SE 1/4, Section 11, T27S, R2E. The soil on-site is comprised mostly of Rosehill silty clay with a small area of Irwin silty clay along the east property line, which are both classified in hydrologic group D. The land is currently used for agricultural purposes and has short grass and bare ground throughout. The site is bordered to the north by the Burlington Northern Santa Fe Railroad, to the east by Savanna at Castle Rock Ranch 8th Addition, to the south by Savanna at Castle Rock Ranch 6th Addition, and to the west by a horse ranch. The site drains primarily to the west into the existing pond on the adjacent ranch. The area designated as Basin B in the enclosed map currently drains to the south with no apparent outfall due to the berms. The outfalls for Basins A and E will remain unchanged with development.

The Rational Method was used to calculate runoff quantities. Runoff coefficients were estimated based on tables presented in the Design Aids section of this report using fully developed conditions. Time of concentration was based on slope, flow velocity and length of flow through each basin and was not allowed to be less than 15 minutes. The HEC-1 computer program was used to route the runoff through the ponds and determine the post-development conditions leaving the site.

The analysis was made based on the available site data which includes the following: 1" = 60' topographic map with 1' contours of the site, a Sedgwick County Soil Survey Map and noted references.

Storm Sewer Design

For the storm sewer hydrologic analysis, the Rational Method was again used. Runoff coefficients were estimated using the charts in the design aids section of this report. For this development, a uniform assumption of the minimum time of concentration of 15 minutes was deemed appropriate. Travel time for flow through defined channels, pipes, etc, for these basins was estimated on the basis of Manning's Equation.

In the hydraulic analysis, the storm sewers are designed for the minor storm, with major storm overflows to be routed through easements and rights-of-way to an appropriate outlet. The minor storm has a recurrence interval of two years. The major storm evaluated has a recurrence interval of one hundred years. To simplify this analysis, the time of concentration is identical for both the major and minor storms.

For each inlet, street flooding and inlet capacity were checked for the minor storm. Conveyance in the street is based on the Modified Manning's Equation, as expressed in the Design of Urban Highway Drainage – The State of the Art, Equation (5-1), pages 5-9. It has been assumed that T_c for street flow is equal to T_c for pipe flow. This is a simplifying, but conservative, assumption since pipe flow velocities generally exceed street flow velocities. For local streets, curb-deep flow is tolerable for the minor storm. For collector streets, a single eight-foot lane should remain unflooded for the minor storm.

Inlet capacities were determined by the methods described in Drainage of Highway Pavements, Hydraulic Engineering Circular #12, using Chart #12 as found in the Design Aids section. City of Wichita Type 1A inlets and 3/8 inch per foot cross slopes have been assumed. Minimum walk grade has been assumed to be 0.3 feet above the top of

curb, unless otherwise noted. Streets have been assumed to have 3-5/8 inch roll curb, unless otherwise noted.

Hydraulic computation for the storm sewer pipe system was performed using PEC's STORM computer program. This program uses Manning's Equation to calculate friction losses for pipes flowing full. Minor losses are computed by momentum principles at each structure. All pipe area is assumed to be reinforced concrete with a Manning's "n" of 0.013. It is desirable to keep the hydraulic grade line at least one foot below the top of curb for the minor storm. The calculations and the STORM analyses for the storm sewers are included in this report.

Design Aids

This section includes material used to assist in designing the drainage system. A 1" = 60' scale Drainage Plan map (Attachment A) and a 1" = 60' scale Four-Corner Plan map (Attachment B) are enclosed in the pockets.

References

Design of Urban Highway Drainage – The State of the Art, by Reitz & Jens, Inc., April 1980.

Drainage of Highway Pavements, Hydraulic Engineering Circular #12, by Tye Engineering, Inc., March 1984.

Interim Drainage and Storm Sewer Policy for Design Criteria and Documentation, City of Wichita, Kansas, 1985.

Soil Survey of Sedgwick County, Kansas, US Department of Agriculture, Soil Conservation Service, 1979.

Project: Savanna at Castle Rock Ranch 10th Addition
 Date: 2/19/2004
 Prep. By: BLB

Manual Input

Total Site

Total Area 15.43 Acres

Soil Group	A (% of Total Area)	B (% of Total Area)	C (% of Total Area)	D (% of Total Area)	Total
	0%	0%	0%	100%	100%
Acres	0.00	0.00	0.00	15.43	15.43

Land Use	Commercial (% of Total Area)	Industrial (% of Total Area)	Multi-Family (% of Total Area)	Public (% of Total Area)	Single Family (% of Total Area)	Vacant/Agriculture (% of Total Area)	Total
Existing	0%	0%	0%	0%	5%	95%	100%
Acres	0.00	0.00	0.00	0.00	0.77	14.66	15.43

Existing
 Length of Flow 700 ft
 Slope 2.29 %
 Waterflow Desc bare / short grass
 Avg Velocity 0.55 ft/sec
 Tc 0.35 hours

15 min <= Tc <= 24 hrs

Runoff Coefficients * Used Soil Group D To Be Conservative

Return Period (Years)	Commercial	Industrial	Multi-Family	Public	Single Family	Vacant/Agriculture
2	0.68	0.68	0.70	0.49	0.50	0.54
5	0.69	0.69	0.73	0.51	0.54	0.56
10	0.73	0.73	0.79	0.56	0.62	0.61
25	0.75	0.75	0.81	0.59	0.66	0.64
50	0.77	0.77	0.83	0.62	0.70	0.67
100	0.80	0.80	0.86	0.66	0.76	0.70

Existing Conditions

Return Period (Years)	Runoff Coefficient *	Rainfall Intensity (in/hr)	Area (Acres)	Runoff (cfs)
2	0.54	3.25	15.43	26.98
5	0.56	3.90	15.43	33.64
10	0.61	4.50	15.43	42.39
25	0.64	5.23	15.43	51.73
50	0.67	5.87	15.43	60.82
100	0.70	6.39	15.43	69.31

Savanna at Castle Rock Ranch 10th Addition

Project: 2/19/2004

Date: BLB

Prep. By: Manual Input

Basin A

Total Area 2.94 Acres

Soil Group	A (% of Total Area)	B (% of Total Area)	C (% of Total Area)	D (% of Total Area)	Total
	0%	0%	0%	100%	100%
Acres	0.00	0.00	0.00	2.94	2.94

Land Use	Commercial (% of Total Area)	Industrial (% of Total Area)	Multi-Family (% of Total Area)	Public (% of Total Area)	Single Family (% of Total Area)	Vacant/Agriculture (% of Total Area)	Total
Existing	0%	0%	0%	0%	0%	100%	100%
Acres	0.00	0.00	0.00	0.00	0.00	2.94	2.94
Future	0%	0%	0%	0%	100%	0%	100%
Acres	0.00	0.00	0.00	0.00	2.94	0.00	2.94

Length of Flow	Existing	Future
Slope	700 ft 1.57 %	750 ft 1.47 %
Waterflow Desc	bare / short grass	lawns \ streets
Avg Velocity	0.55 ft/sec	0.35 ft/sec
Tc	0.35 hours	0.60 hours

15 min <= Tc <= 24 hrs

Runoff Coefficients * Used Soil Group D To Be Conservative

Return Period (Years)	Commercial	Industrial	Multi-Family	Public	Single Family	Vacant/Agriculture
2	0.68	0.68	0.70	0.49	0.50	0.54
5	0.69	0.69	0.73	0.51	0.54	0.56
10	0.73	0.73	0.79	0.56	0.62	0.61
25	0.75	0.75	0.81	0.59	0.66	0.64
50	0.77	0.77	0.83	0.62	0.70	0.67
100	0.80	0.80	0.86	0.66	0.76	0.70

Existing Conditions

Return Period (Years)	Runoff Coefficient *	Rainfall Intensity (in/hr)	Area (Acres)	Runoff (cfs)
2	0.54	3.25	2.94	5.16
5	0.56	3.90	2.94	6.42
10	0.61	4.50	2.94	8.07
25	0.64	5.23	2.94	9.84
50	0.67	5.87	2.94	11.56
100	0.70	6.39	2.94	13.15

Future Conditions

Return Period (Years)	Runoff Coefficient *	Rainfall Intensity (in/hr)	Area (Acres)	Runoff (cfs)
2	0.50	2.39	2.94	3.51
5	0.54	2.93	2.94	4.65
10	0.62	3.41	2.94	6.22
25	0.66	3.99	2.94	7.74
50	0.70	4.50	2.94	9.26
100	0.76	4.93	2.94	11.02

Project: Savanna at Castle Rock Ranch 10th Addition
 Date: 2/19/2004
 Prep. By: BLB

Manual Input

Basin B

Total Area	0.47 Acres						
Soil Group	A	B	C	D	Total		
	(% of Total Area)	(% of Total Area)	(% of Total Area)	(% of Total Area)	(% of Total Area)		
Acres	0.00	0.00	0.00	0.47	0.47		
Land Use	Commercial	Industrial	Multi-Family	Public	Single Family	Vacant/Agriculture	Total
Existing	(% of Total Area)	(% of Total Area)	(% of Total Area)	(% of Total Area)	(% of Total Area)	(% of Total Area)	(% of Total Area)
Acres	0.00	0.00	0.00	0.00	0.00	0.47	0.47
Future	0.00	0.00	0.00	0.00	100%	0.00	100%
Acres	0.00	0.00	0.00	0.00	0.47	0.00	0.47

Length of Flow	Existing	Future
Slope	250 ft	250 ft
Waterflow Desc	0.40 %	0.40 %
Avg Velocity	bare / short grass	lawns \ streets
Tc	0.55 ft/sec	0.35 ft/sec
	0.13 hours	0.20 hours

15 min <= Tc <= 24 hrs

Runoff Coefficients * Used Soil Group D To Be Conservative

Return Period (Years)	Commercial	Industrial	Multi-Family	Public	Single Family	Vacant/Agriculture
2	0.68	0.68	0.70	0.49	0.50	0.54
5	0.69	0.69	0.73	0.51	0.54	0.56
10	0.73	0.73	0.79	0.56	0.62	0.61
25	0.75	0.75	0.81	0.59	0.66	0.64
50	0.77	0.77	0.83	0.62	0.70	0.67
100	0.80	0.80	0.86	0.66	0.76	0.70

Existing Conditions

Return Period (Years)	Runoff Coefficient *	Rainfall Intensity (in/hr)	Area (Acres)	Runoff (cfs)
2	0.54	3.83	0.47	0.97
5	0.56	4.56	0.47	1.20
10	0.61	5.22	0.47	1.50
25	0.64	6.06	0.47	1.82
50	0.67	6.78	0.47	2.14
100	0.70	7.37	0.47	2.42

Future Conditions

Return Period (Years)	Runoff Coefficient *	Rainfall Intensity (in/hr)	Area (Acres)	Runoff (cfs)
2	0.50	3.83	0.47	0.90
5	0.54	4.56	0.47	1.16
10	0.62	5.22	0.47	1.52
25	0.66	6.06	0.47	1.88
50	0.70	6.78	0.47	2.23
100	0.76	7.37	0.47	2.63

Savanna at Castle Rock Ranch 10th Addition

Project: 2/19/2004

Date: BLB

Manual Input

Basin C

Total Area 5.10 Acres

Soil Group	A (% of Total Area)	B (% of Total Area)	C (% of Total Area)	D (% of Total Area)	Total
	0%	0%	0%	100%	100%
Acres	0.00	0.00	0.00	5.10	5.10

Land Use	Commercial (% of Total Area)	Industrial (% of Total Area)	Multi-Family (% of Total Area)	Public (% of Total Area)	Single Family (% of Total Area)	Vacant/Agriculture (% of Total Area)	Total
Existing	0%	0%	0%	0%	0%	100%	100%
Acres	0.00	0.00	0.00	0.00	0.00	5.10	5.10
Future	0%	0%	0%	0%	80%	20%	100%
Acres	0.00	0.00	0.00	0.00	4.08	1.02	5.10

Existing

Length of Flow 735 ft
 Slope 1.67 %
 Waterflow Desc bare / short grass
 Avg Velocity 0.55 ft/sec
 Tc 0.37 hours

Future

980 ft
 1.27 %
 lawns \ streets
 0.35 ft/sec
 0.78 hours

15 min <= Tc <= 24 hrs

Runoff Coefficients * Used Soil Group D To Be Conservative

Return Period (Years)	Commercial	Industrial	Multi-Family	Public	Single Family	Vacant/Agriculture
2	0.68	0.68	0.70	0.49	0.50	0.54
5	0.69	0.69	0.73	0.51	0.54	0.56
10	0.73	0.73	0.79	0.56	0.62	0.61
25	0.75	0.75	0.81	0.59	0.66	0.64
50	0.77	0.77	0.83	0.62	0.70	0.67
100	0.80	0.80	0.86	0.66	0.76	0.70

Existing Conditions

Return Period (Years)	Runoff Coefficient *	Rainfall Intensity (in/hr)	Area (Acres)	Runoff (cfs)
2	0.54	3.17	5.10	8.73
5	0.56	3.81	5.10	10.88
10	0.61	4.40	5.10	13.69
25	0.64	5.12	5.10	16.71
50	0.67	5.75	5.10	19.65
100	0.70	6.26	5.10	22.35

Future Conditions

Return Period (Years)	Runoff Coefficient *	Rainfall Intensity (in/hr)	Area (Acres)	Runoff (cfs)
2	0.51	2.02	5.10	5.23
5	0.54	2.50	5.10	6.94
10	0.62	2.93	5.10	9.23
25	0.66	3.44	5.10	11.51
50	0.69	3.88	5.10	13.73
100	0.75	4.28	5.10	16.33

Project: Savanna at Castle Rock Ranch 10th Addition
 Date: 2/18/2004
 Prep. By: BLB

Manual Input

Basin D

Total Area 4.69 Acres

Soil Group	A (% of Total Area)	B (% of Total Area)	C (% of Total Area)	D (% of Total Area)	Total
	0%	0%	0%	100%	100%
Acres	0.00	0.00	0.00	4.69	4.69

Land Use	Commercial (% of Total Area)	Industrial (% of Total Area)	Multi-Family (% of Total Area)	Public (% of Total Area)	Single Family (% of Total Area)	Vacant/Agriculture (% of Total Area)	Total
Existing	0%	0%	0%	0%	0%	100%	100%
Acres	0.00	0.00	0.00	0.00	0.00	4.69	4.69
Future	0%	0%	0%	0%	70%	30%	100%
Acres	0.00	0.00	0.00	0.00	3.28	1.41	4.69

Existing
 Length of Flow 900 ft
 Slope 1.78 %
 Waterflow Desc bare/ short grass
 Avg Velocity 0.55 ft/sec
 Tc 0.45 hours

Future
 Length of Flow 920 ft
 Slope 1.74 %
 Waterflow Desc lawns \ streets
 Avg Velocity 0.35 ft/sec
 Tc 0.73 hours

15 min <= Tc <= 24 hrs

Runoff Coefficients * Used Soil Group D To Be Conservative

Return Period (Years)	Commercial	Industrial	Multi-Family	Public	Single Family	Vacant/Agriculture
2	0.68	0.68	0.70	0.49	0.50	0.54
5	0.69	0.69	0.73	0.51	0.54	0.56
10	0.73	0.73	0.79	0.56	0.62	0.61
25	0.75	0.75	0.81	0.59	0.66	0.64
50	0.77	0.77	0.83	0.62	0.70	0.67
100	0.80	0.80	0.86	0.66	0.76	0.70

Existing Conditions

Return Period (Years)	Runoff Coefficient *	Rainfall Intensity (in/hr)	Area (Acres)	Runoff (cfs)
2	0.54	2.84	4.69	7.19
5	0.56	3.43	4.69	9.01
10	0.61	3.98	4.69	11.39
25	0.64	4.63	4.69	13.90
50	0.67	5.21	4.69	16.37
100	0.70	5.69	4.69	18.68

Future Conditions

Return Period (Years)	Runoff Coefficient *	Rainfall Intensity (in/hr)	Area (Acres)	Runoff (cfs)
2	0.51	2.11	4.69	5.07
5	0.55	2.61	4.69	6.68
10	0.62	3.05	4.69	8.83
25	0.65	3.57	4.69	10.95
50	0.69	4.03	4.69	13.06
100	0.74	4.43	4.69	15.42

Savanna at Castle Rock Ranch 10th Addition

Project: 2/18/2004
 Date: BLB
 Prep. By: Manual Input

Basin E

Total Area 2.23 Acres

Soil Group	A (% of Total Area)	B (% of Total Area)	C (% of Total Area)	D (% of Total Area)	Total
	0%	0%	0%	100%	100%
Acres	0.00	0.00	0.00	2.23	2.23

Land Use	Commercial (% of Total Area)	Industrial (% of Total Area)	Multi-Family (% of Total Area)	Public (% of Total Area)	Single Family (% of Total Area)	Vacant/Agriculture (% of Total Area)	Total
Existing	0%	0%	0%	0%	15%	85%	100%
Acres	0.00	0.00	0.00	0.00	0.33	1.90	2.23
Future	0%	0%	0%	0%	95%	5%	100%
Acres	0.00	0.00	0.00	0.00	2.12	0.11	2.23

Length of Flow 580 ft
 Slope 2.00 %
 Waterflow Desc bare / short grass
 Avg Velocity 0.55 ft/sec
 Tc 0.29 hours

Future 580 ft
 2.00 %
 lawns \ streets
 0.35 ft/sec
 0.46 hours

15 min <= Tc <= 24 hrs

Runoff Coefficients * Used Soil Group D To Be Conservative

Return Period (Years)	Commercial	Industrial	Multi-Family	Public	Single Family	Vacant/Agriculture
2	0.68	0.68	0.70	0.49	0.50	0.54
5	0.69	0.69	0.73	0.51	0.54	0.56
10	0.73	0.73	0.79	0.56	0.62	0.61
25	0.75	0.75	0.81	0.59	0.66	0.64
50	0.77	0.77	0.83	0.62	0.70	0.67
100	0.80	0.80	0.86	0.66	0.76	0.70

Existing Conditions

Return Period (Years)	Runoff Coefficient *	Rainfall Intensity (in/hr)	Area (Acres)	Runoff (cfs)
2	0.53	3.61	2.23	4.30
5	0.56	4.31	2.23	5.35
10	0.61	4.95	2.23	6.75
25	0.64	5.75	2.23	8.24
50	0.67	6.44	2.23	9.69
100	0.71	7.00	2.23	11.07

Future Conditions

Return Period (Years)	Runoff Coefficient *	Rainfall Intensity (in/hr)	Area (Acres)	Runoff (cfs)
2	0.50	2.78	2.23	3.11
5	0.54	3.37	2.23	4.07
10	0.62	3.90	2.23	5.39
25	0.66	4.55	2.23	6.69
50	0.70	5.12	2.23	7.98
100	0.76	5.59	2.23	9.44



S. TOPEKA • WICHITA, KANSAS 67202

316-262-2691 • FAX 316-262-3003

www.pec1.com • designers@pec1.com

Project _____

Date _____

Item _____

By _____

DETERMINE CAPACITIES OF ROLL CURB STREETS w/ 0.3' WALK GRADE
FOR 100-YR STORM ANALYSIS (32' ROW)

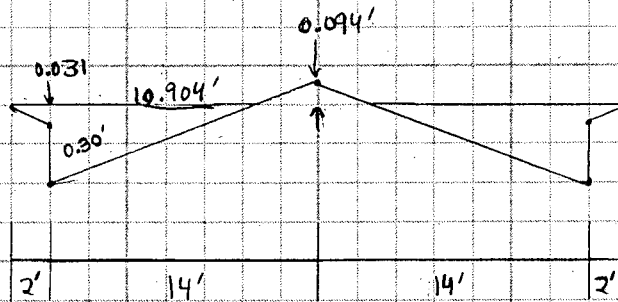

$$n = \frac{(2 \times 1.5 \times 0.030) + (2 \times 3.05 \times 0.013) + (2 \times 12 \times 0.016)}{33.1} = 0.01672$$

$$A = (2 \times \frac{1}{2} \times 2 \times 0.031) + (2 \times \frac{1}{2} \times 10.904 \times 0.331) = 3.671 \text{ SF}$$

$$P = 33.1$$

$$R = \frac{A}{P} = \frac{3.671}{33.1} = 0.111$$

$$R^{2/3} = 0.231$$

$$Q = \frac{1.486}{n} A R^{2/3} S^{1/2}$$

$$Q = \left(\frac{1.486}{0.01672} \right) (3.671) (0.231) (S^{1/2})$$

$$Q = 75.31 (S^{1/2})$$



3 S. TOPEKA • WICHITA, KANSAS 67202
316-262-2691 • FAX 316-262-3003
www.pec1.com • designers@pec1.com

Project Savanna 10th

03342

Date 2-19-04

Item Street Flow Checks

By BLB

Runoff Coefficients

$C_2 = 0.44$

$C_{100} = 0.61$

Intensity

$T_c = 15 \text{ min}$

$i_2 = 3.5 \text{ in/hr}$

$i_{100} = 7.8 \text{ in/hr}$

Basin	Node	Area	C_2	C_{100}	Q_2	Q_{100}
C1	202	1.85	0.44	0.61	2.85	8.80
C3	102	1.63	0.44	0.61	2.51	7.76

2 Year

Node	Q_2	Street Slope	d	d _{max}	Comment
202	2.85	1.50	0.18	0.30	OK

* By inspection, all nodes are OK

100 Year

Location	Q_{100}	Q_{pipe}	Q_{street}	S	Q_{max}	Comment
Approaching Node 202	8.80	2.85	5.95	1.50	92.24	OK

* By inspection, all nodes are OK



3 S. TOPEKA • WICHITA, KANSAS 67202
316-262-2691 • FAX 316-262-3003
www.pec1.com • designers@pec1.com

Project Savanna 10th

08342

Date 2-19-04

Item Inlet Sizing

* All inlets in sump

By BLB

Curb Inlets

Node	Q _{in}	Q _{max} L=5'	Q _{max} L=10'	Use L=
102	2.51	11	22	5'
202	2.85	11	22	5'

Area Inlets

Basin	Node	Area	C ₂	C ₁₀₀	Q ₂	Q ₁₀₀
B	303	0.47	0.44	0.61	0.72	2.24

Node	Q ₁₀₀	Size	Ponding Depth
303	2.24	2'x2'	0.22'

2'x2' Area Inlet - Neenah Grate R4B26

13 SF of open area

8 F Perimeter

Circular Pond Sizing with Elevations

Floor Area (Acres)	0.13
Floor Elevation (ft)	1341.60
Static Pool Elevation (ft)	1351.60
Side Slopes to Static (_ :1)	3
Side Slopes beyond Static (_ :1)	6

	Elevation (ft)	Radius (ft)	Area (ft ²)	Area (Acres)	Storage (ft ³)	Storage (C.Y.)
	1341.60	42.46	5662.80	0.13	0.00	0.00
	1342.60	45.46	6491.35	0.15	6077.08	225.08
	1343.60	48.46	7376.46	0.17	13039.26	482.94
	1344.60	51.46	8318.11	0.19	20971.36	776.72
	1345.60	54.46	9316.31	0.21	29958.22	1109.56
	1346.60	57.46	10371.06	0.24	40084.64	1484.62
	1347.60	60.46	11482.35	0.26	51435.46	1905.02
	1348.60	63.46	12650.20	0.29	64095.50	2373.91
	1349.60	66.46	13874.59	0.32	78149.58	2894.43
	1350.60	69.46	15155.54	0.35	93682.52	3469.72
Static Pool	1351.60	72.46	16493.03	0.38	110779.15	4102.93
	1352.60	78.46	19337.66	0.44	137502.53	5092.69
	1353.60	84.46	22408.49	0.51	168427.71	6238.06
	1354.60	90.46	25705.50	0.59	203893.98	7551.63
	1355.60	96.46	29228.72	0.67	244240.63	9045.95
	1356.60	102.46	32978.13	0.76	289806.96	10733.59
	1357.60	108.46	36953.73	0.85	340932.25	12627.12
	1358.60	114.46	41155.53	0.94	397955.80	14739.10
	1359.60	120.46	45583.52	1.05	461216.90	17082.11

Circular Pond Sizing with Elevations

Floor Area (Acres)	0.13
Floor Elevation (ft)	1343.00
Static Pool Elevation (ft)	1353.00
Side Slopes to Static (_:1)	3
Side Slopes beyond Static (_:1)	6

	Elevation (ft)	Radius (ft)	Area (ft^2)	Area (Acres)	Storage (ft^3)	Storage (C.Y.)
	1343.00	42.46	5662.80	0.13	0.00	0.00
	1344.00	45.46	6491.35	0.15	6077.08	225.08
	1345.00	48.46	7376.46	0.17	13039.26	482.94
	1346.00	51.46	8318.11	0.19	20971.36	776.72
	1347.00	54.46	9316.31	0.21	29958.22	1109.56
	1348.00	57.46	10371.06	0.24	40084.64	1484.62
	1349.00	60.46	11482.35	0.26	51435.46	1905.02
	1350.00	63.46	12650.20	0.29	64095.50	2373.91
	1351.00	66.46	13874.59	0.32	78149.58	2894.43
	1352.00	69.46	15155.54	0.35	93682.52	3469.72
Static Pool	1353.00	72.46	16493.03	0.38	110779.15	4102.93
	1354.00	78.46	19337.66	0.44	137502.53	5092.69
	1355.00	84.46	22408.49	0.51	168427.71	6238.06
	1356.00	90.46	25705.50	0.59	203893.98	7551.63
	1357.00	96.46	29228.72	0.67	244240.63	9045.95
	1358.00	102.46	32978.13	0.76	289806.96	10733.59
	1359.00	108.46	36953.73	0.85	340932.25	12627.12
	1360.00	114.46	41155.53	0.94	397955.80	14739.10
	1361.00	120.46	45583.52	1.05	461216.90	17082.11

19.0 Maximum Q (cfs)
5.000 Weir Width (feet)
1351.60 Weir Elevation

<u>Q</u> (cfs)	<u>Weir</u> <u>Width</u> (feet)	<u>Weir</u> <u>Elevation</u>	<u>q</u>	<u>Critical</u> <u>Depth</u> (feet)	<u>Energy</u> <u>Head</u> (feet)	<u>Water</u> <u>Surface</u> <u>Elevation</u>
0.0	5.000	1351.60	0.0	0.00	0.00	1351.60
1.9	5.000	1351.60	0.4	0.16	0.25	1351.85
3.8	5.000	1351.60	0.8	0.26	0.39	1351.99
5.7	5.000	1351.60	1.1	0.34	0.51	1352.11
7.6	5.000	1351.60	1.5	0.42	0.62	1352.22
9.5	5.000	1351.60	1.9	0.48	0.72	1352.32
11.4	5.000	1351.60	2.3	0.54	0.82	1352.42
13.3	5.000	1351.60	2.7	0.60	0.91	1352.51
15.2	5.000	1351.60	3.0	0.66	0.99	1352.59
17.1	5.000	1351.60	3.4	0.71	1.07	1352.67
19.0	5.000	1351.60	3.8	0.77	1.15	1352.75

CURRENT DATE: 03-09-2004

FILE DATE: 03-09-2004

CURRENT TIME: 10:28:48

FILE NAME: POND2

FHWA CULVERT ANALYSIS
HY-8, VERSION 6.1

C U L V N O.	SITE DATA			CULVERT SHAPE, MATERIAL, INLET				
	INLET ELEV. (ft)	OUTLET ELEV. (ft)	CULVERT LENGTH (ft)	BARRELS SHAPE MATERIAL	SPAN (ft)	RISE (ft)	MANNING n	INLET TYPE
1	1353.00	1348.40	75.14	1 RCP	1.50	1.50	.012	CONVENTIONAL
2								
3								
4								
5								
6								

SUMMARY OF CULVERT FLOWS (cfs)

FILE: POND2

DATE: 03-09-2004

ELEV (ft)	TOTAL	1	2	3	4	5	6	ROADWAY	ITR
1353.00	0.0	0.0	0.0	0.0	0.0	0.0	0.0	0.00	0
1353.66	1.9	0.0	0.0	0.0	0.0	0.0	0.0	0.00	0
1354.02	3.8	0.0	0.0	0.0	0.0	0.0	0.0	0.00	0
1354.30	5.7	0.0	0.0	0.0	0.0	0.0	0.0	0.00	0
1354.58	7.6	0.0	0.0	0.0	0.0	0.0	0.0	0.00	0
1354.90	9.5	0.0	0.0	0.0	0.0	0.0	0.0	0.00	0
1355.30	11.4	0.0	0.0	0.0	0.0	0.0	0.0	0.00	0
1355.78	13.3	0.0	0.0	0.0	0.0	0.0	0.0	0.00	0
1356.34	15.2	0.0	0.0	0.0	0.0	0.0	0.0	0.00	0
1356.97	17.1	0.0	0.0	0.0	0.0	0.0	0.0	0.00	0
1357.67	19.0	0.0	0.0	0.0	0.0	0.0	0.0	0.00	0
0.00	0.0	0.0	0.0	0.0	0.0	0.0	0.0	0.0	OVERTOPPING

SUMMARY OF ITERATIVE SOLUTION ERRORS

FILE: POND2

DATE: 03-09-2004

HEAD ELEV (ft)	HEAD ERROR (ft)	TOTAL FLOW (cfs)	FLOW ERROR (cfs)	% FLOW ERROR
1353.00	0.000	0.00	0.00	0.00
1353.66	0.000	1.90	0.00	0.00
1354.02	0.000	3.80	0.00	0.00
1354.30	0.000	5.70	0.00	0.00
1354.58	0.000	7.60	0.00	0.00
1354.90	0.000	9.50	0.00	0.00
1355.30	0.000	11.40	0.00	0.00
1355.78	0.000	13.30	0.00	0.00
1356.34	0.000	15.20	0.00	0.00
1356.97	0.000	17.10	0.00	0.00
1357.67	0.000	19.00	0.00	0.00

<1> TOLERANCE (ft) = 0.010

<2> TOLERANCE (%) = 1.000

CLIENT DATE: 03-09-2004
 PRINT TIME: 10:28:48

FILE DATE: 03-09-2004
 FILE NAME: POND2

PERFORMANCE CURVE FOR CULVERT 1 - 1(1.50 (ft) BY 1.50 (ft)) RCP

DIS- CHARGE FLOW (cfs)	HEAD- WATER ELEV. (ft)	INLET CONTROL DEPTH (ft)	OUTLET CONTROL DEPTH (ft)	FLOW NORMAL TYPE <F4>	NORMAL DEPTH (ft)	CRIT. DEPTH (ft)	OUTLET DEPTH (ft)	TW DEPTH (ft)	OUTLET VEL. (fps)	TW VEL. (fps)
0.00	1353.00	0.00	0.00	0-NF	0.00	0.00	0.00	3.20	0.00	0.00
1.90	1353.66	0.66	0.66	1-S1f	0.25	0.51	0.70	3.20	2.35	0.00
3.80	1354.02	1.02	1.02	1-S1f	0.37	0.74	0.90	3.20	3.43	0.00
5.70	1354.30	1.30	1.30	1-S1f	0.46	0.92	1.10	3.20	4.09	0.00
7.60	1354.58	1.58	1.58	1-S1f	0.53	1.07	1.20	3.20	5.01	0.00
9.50	1354.90	1.90	1.90	1-S1f	0.60	1.19	1.30	3.20	5.86	0.00
11.40	1355.30	2.30	2.30	1-S1f	0.66	1.28	1.40	3.20	6.68	0.00
13.30	1355.78	2.78	2.78	1-S1f	0.72	1.37	1.50	3.20	7.53	0.00
15.20	1356.34	3.34	3.34	1-S1f	0.78	1.45	1.50	3.20	8.60	0.00
17.10	1356.97	3.97	2.03	4-S2n	0.84	1.50	0.89	3.20	15.66	0.00
19.00	1357.67	4.67	2.83	4-S2n	0.90	1.50	0.96	3.20	15.93	0.00

El. inlet face invert 1353.00 ft El. outlet invert 1348.40 ft
 El. inlet throat invert 0.00 ft El. inlet crest 0.00 ft

* SITE DATA ***** CULVERT INVERT *****
 INLET STATION 0.00 ft
 INLET ELEVATION 1353.00 ft
 OUTLET STATION 75.00 ft
 OUTLET ELEVATION 1348.40 ft
 NUMBER OF BARRELS 1
 SLOPE (V/H) 0.0613
 CULVERT LENGTH ALONG SLOPE 75.14 ft

***** CULVERT DATA SUMMARY *****
 BARREL SHAPE CIRCULAR
 BARREL DIAMETER 1.50 ft
 BARREL MATERIAL CONCRETE
 BARREL MANNING'S n 0.012
 INLET TYPE CONVENTIONAL
 INLET EDGE AND WALL GROOVED END PROJECTION
 INLET DEPRESSION NONE

PRINT DATE: 03-09-2004
PRINT TIME: 10:28:48

FILE DATE: 03-09-2004
FILE NAME: POND2

TAILWATER

CONSTANT WATER SURFACE ELEVATION
1351.60

ROADWAY OVERTOPPING DATA

ROADWAY SURFACE	GRAVEL
EMBANKMENT TOP WIDTH	20.00 ft
CREST LENGTH	50.00 ft
OVERTOPPING CREST ELEVATION	1355.00 ft

Open Channel Sizing

$k = 1.486$
 $n = 0.030$
 $R = 0.346 \text{ ft}$
 $S = 0.0050 \text{ ft / ft}$
 $V = 1.725 \text{ ft / s}$
 $w = 4.00 \text{ ft}$
 $d = 1.06 \text{ ft}$
Side Slope = 4 : 1
 $A = 8.698 \text{ ft}^2$
 $P = 25.173 \text{ ft}$

Total Channel Width = 12.46 ft

$$Q = 15.00 \text{ ft}^3 / \text{s}$$

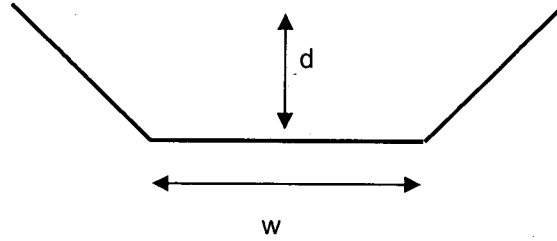

```

*****
*
* FLOOD HYDROGRAPH PACKAGE (HEC-1)
*   JUN 1998
*   VERSION 4.1
*
* RUN DATE 09MAR04 TIME 10:47:28
*
*****

```

```

*****
*
* U.S. ARMY CORPS OF ENGINEERS
* HYDROLOGIC ENGINEERING CENTER
* 609 SECOND STREET
* DAVIS, CALIFORNIA 95616
* (916) 756-1104
*
*****

```

```

X   X XXXXXXXX XXXXX      X
X   X X      X   X      XX
X   X X      X           X
XXXXXXXX XXXX   X      XXXXX X
X   X X      X           X
X   X X      X   X      X
X   X XXXXXXXX XXXXX      XXX

```

THIS PROGRAM REPLACES ALL PREVIOUS VERSIONS OF HEC-1 KNOWN AS HEC1 (JAN 73), HEC1GS, HEC1DB, AND HEC1KW.

THE DEFINITIONS OF VARIABLES -RTIMP- AND -RTIOR- HAVE CHANGED FROM THOSE USED WITH THE 1973-STYLE INPUT STRUCTURE. THE DEFINITION OF -AMSK- ON RM-CARD WAS CHANGED WITH REVISIONS DATED 28 SEP 81. THIS IS THE FORTRAN77 VERSION
 NEW OPTIONS: DAMBREAK OUTFLOW SUBMERGENCE , SINGLE EVENT DAMAGE CALCULATION, DSS:WRITE STAGE FREQUENCY,
 DSS:READ TIME SERIES AT DESIRED CALCULATION INTERVAL LOSS RATE:GREEN AND AMPT INFILTRATION
 KINEMATIC WAVE: NEW FINITE DIFFERENCE ALGORITHM

HEC-1 INPUT

LINE ID.....1.....2.....3.....4.....5.....6.....7.....8.....9.....10

```

1 ID SAVANNAH AT CASTLE ROCK RANCH 10TH ADDITION
2 ID DEVELOPED CONDITIONS
3 ID BY BLB DATE 03-09-04

```

*** LIST ***
 *** FREE ***

*DIAGRAM

```

4 IT 15 01JAN03 1200 0 02JAN03 2000
5 IN 15 01JAN03 1200
6 IO 0 5
7 JR PREC 7.8
*
*
*
8 KK BSNA
9 BA 0.005
10 PB 1.00
11 PC 0.000 0.003 0.006 0.008 0.011 0.014 0.017 0.019 0.022 0.025
12 PC 0.029 0.032 0.035 0.038 0.042 0.045 0.048 0.052 0.056 0.060
13 PC 0.064 0.068 0.072 0.076 0.080 0.085 0.090 0.095 0.100 0.105
14 PC 0.110 0.115 0.120 0.127 0.134 0.140 0.147 0.155 0.163 0.172
15 PC 0.181 0.193 0.204 0.220 0.235 0.259 0.283 0.387 0.663 0.699

```

16	PC	0.735	0.754	0.772	0.786	0.799	0.810	0.820	0.828	0.835	0.843
17	PC	0.850	0.858	0.865	0.873	0.880	0.885	0.889	0.894	0.898	0.903
18	PC	0.907	0.912	0.916	0.921	0.925	0.929	0.934	0.938	0.943	0.947
19	PC	0.952	0.955	0.958	0.961	0.964	0.967	0.970	0.973	0.976	0.979
20	PC	0.982	0.985	0.988	0.991	0.994	0.997	1.000			
21	LS	0	68	10							
22	UD	0.200									
	*										
	*										
23	KK	BSNB									
24	BA	0.001									
25	PB	1.00									
26	PC	0.000	0.003	0.006	0.008	0.011	0.014	0.017	0.019	0.022	0.025
27	PC	0.029	0.032	0.035	0.038	0.042	0.045	0.048	0.052	0.056	0.060
28	PC	0.064	0.068	0.072	0.076	0.080	0.085	0.090	0.095	0.100	0.105
29	PC	0.110	0.115	0.120	0.127	0.134	0.140	0.147	0.155	0.163	0.172
30	PC	0.181	0.193	0.204	0.220	0.235	0.259	0.283	0.387	0.663	0.699
31	PC	0.735	0.754	0.772	0.786	0.799	0.810	0.820	0.828	0.835	0.843
32	PC	0.850	0.858	0.865	0.873	0.880	0.885	0.889	0.894	0.898	0.903
33	PC	0.907	0.912	0.916	0.921	0.925	0.929	0.934	0.938	0.943	0.947
34	PC	0.952	0.955	0.958	0.961	0.964	0.967	0.970	0.973	0.976	0.979
35	PC	0.982	0.985	0.988	0.991	0.994	0.997	1.000			
36	LS	0	68	10							
37	UD	0.120									
	*										
	*										

HEC-1 INPUT

PAGE 2

LINE ID.....1.....2.....3.....4.....5.....6.....7.....8.....9.....10

38	KK	BSND									
39	BA	0.007									
40	PB	1.00									
41	PC	0.000	0.003	0.006	0.008	0.011	0.014	0.017	0.019	0.022	0.025
42	PC	0.029	0.032	0.035	0.038	0.042	0.045	0.048	0.052	0.056	0.060
43	PC	0.064	0.068	0.072	0.076	0.080	0.085	0.090	0.095	0.100	0.105
44	PC	0.110	0.115	0.120	0.127	0.134	0.140	0.147	0.155	0.163	0.172
45	PC	0.181	0.193	0.204	0.220	0.235	0.259	0.283	0.387	0.663	0.699
46	PC	0.735	0.754	0.772	0.786	0.799	0.810	0.820	0.828	0.835	0.843
47	PC	0.850	0.858	0.865	0.873	0.880	0.885	0.889	0.894	0.898	0.903
48	PC	0.907	0.912	0.916	0.921	0.925	0.929	0.934	0.938	0.943	0.947
49	PC	0.952	0.955	0.958	0.961	0.964	0.967	0.970	0.973	0.976	0.979
50	PC	0.982	0.985	0.988	0.991	0.994	0.997	1.000			
51	LS	0	68	10							
52	UD	0.200									
	*										
	*										
53	KK	B&D									
54	HC	2	0								
	*										
	*										
55	KK	POND2									
56	RS	1	ELEV	1346.0							
57	SA	0.58	0.67	0.75	0.84						
58	SE	1353.0	1354.0	1355.0	1356.0						
59	SQ	0	1.9	3.8	5.7	7.6	9.5	11.4	13.3	15.2	17.1

```

      *
103   KK   PD1&E
104   HC   2   0
      *
      *
      *
105   ZZ

```

SCHEMATIC DIAGRAM OF STREAM NETWORK

INPUT LINE (V) ROUTING (---->) DIVERSION OR PUMP FLOW
 NO. (.) CONNECTOR (<----) RETURN OF DIVERTED OR PUMPED FLOW

```

8     BSNA
      .
23    .     BSNB
      .
38    .     .     BSND
      .
53    .     B&D.....
      .     V
      .     V
55    .     POND2
      .
63    .     .     BSNC
      .
78    .     PD2&C.....
      .     V
      .     V
80    .     POND1
      .
88    .     .     BSNE
      .
103   .     PD1&E.....

```

(***) RUNOFF ALSO COMPUTED AT THIS LOCATION

```

1*****
*
* FLOOD HYDROGRAPH PACKAGE (HEC-1) *
*   JUN 1998                   *
*   VERSION 4.1                 *
*
* RUN DATE 09MAR04 TIME 10:47:28 *
*
*****

```

```

*****
*
* U.S. ARMY CORPS OF ENGINEERS *
* HYDROLOGIC ENGINEERING CENTER *
*   609 SECOND STREET          *
*   DAVIS, CALIFORNIA 95616    *
*   (916) 756-1104            *
*
*****

```

SAVANNA AT CASTLE ROCK RANCH 10TH ADDITION
DEVELOPED CONDITIONS
BY BLB DATE 03-09-04

IO

OUTPUT CONTROL VARIABLES

IPRNT 0 PRINT CONTROL
IPLOT 5 PLOT CONTROL
QSCAL 0. HYDROGRAPH PLOT SCALE

IT

HYDROGRAPH TIME DATA

NMIN 15 MINUTES IN COMPUTATION INTERVAL
IDATE 1JAN 3 STARTING DATE
ITIME 1200 STARTING TIME
NQ 129 NUMBER OF HYDROGRAPH ORDINATES
NDDATE 2JAN 3 ENDING DATE
NDTIME 2000 ENDING TIME
ICENT 19 CENTURY MARK

COMPUTATION INTERVAL .25 HOURS
TOTAL TIME BASE 32.00 HOURS

ENGLISH UNITS

DRAINAGE AREA SQUARE MILES
PRECIPITATION DEPTH INCHES
LENGTH, ELEVATION FEET
FLOW CUBIC FEET PER SECOND
STORAGE VOLUME ACRE-FEET
SURFACE AREA ACRES
TEMPERATURE DEGREES FAHRENHEIT

JP

MULTI-PLAN OPTION

NPLAN 1 NUMBER OF PLANS

JR

MULTI-RATIO OPTION

RATIOS OF PRECIPITATION
7.80

*** **

8 KK

* *
* BSNA *
* *

5 IN

TIME DATA FOR INPUT TIME SERIES

JXMIN 15 TIME INTERVAL IN MINUTES
JXDATE 1JAN 3 STARTING DATE
JXTIME 1200 STARTING TIME

SUBBASIN RUNOFF DATA

BA

SUBBASIN CHARACTERISTICS

TAREA .00 SUBBASIN AREA

PRECIPITATION DATA

10 PB STORM 1.00 BASIN TOTAL PRECIPITATION

11 PI INCREMENTAL PRECIPITATION PATTERN

.00	.00	.00	.00	.00	.00	.00	.00	.00	.00	.00
.00	.00	.00	.00	.00	.00	.00	.00	.00	.00	.00
.00	.00	.00	.00	.01	.01	.00	.01	.00	.01	.01
.01	.00	.01	.01	.01	.01	.01	.01	.01	.01	.01
.01	.01	.02	.02	.02	.02	.10	.28	.04	.04	.04
.02	.02	.01	.01	.01	.01	.01	.01	.01	.01	.01
.01	.01	.01	.01	.00	.00	.00	.00	.00	.00	.00
.00	.00	.00	.00	.00	.00	.00	.00	.00	.00	.00
.00	.00	.00	.00	.00	.00	.00	.00	.00	.00	.00
.00	.00	.00	.00	.00	.00	.00	.00	.00	.00	.00

21 LS SCS LOSS RATE

STRIL .94 INITIAL ABSTRACTION
 CRVNBR 68.00 CURVE NUMBER
 RTIMP 10.00 PERCENT IMPERVIOUS AREA

22 UD SCS DIMENSIONLESS UNITGRAPH

TLAG .20 LAG

WARNING *** TIME INTERVAL IS GREATER THAN .29*LAG

UNIT HYDROGRAPH
 6 END-OF-PERIOD ORDINATES

7. 5. 1. 0. 0. 0.

HYDROGRAPH AT STATION BSNA

DA	MON	HRMN	ORD	RAIN	LOSS	EXCESS	COMP Q	*	DA	MON	HRMN	ORD	RAIN	LOSS	EXCESS	COMP Q
1	JAN	1200	1	.00	.00	.00	0.	*	2	JAN	0415	66	.00	.00	.00	0.
1	JAN	1215	2	.00	.00	.00	0.	*	2	JAN	0430	67	.00	.00	.00	0.
1	JAN	1230	3	.00	.00	.00	0.	*	2	JAN	0445	68	.00	.00	.00	0.
1	JAN	1245	4	.00	.00	.00	0.	*	2	JAN	0500	69	.00	.00	.00	0.
1	JAN	1300	5	.00	.00	.00	0.	*	2	JAN	0515	70	.00	.00	.00	0.
1	JAN	1315	6	.00	.00	.00	0.	*	2	JAN	0530	71	.00	.00	.00	0.
1	JAN	1330	7	.00	.00	.00	0.	*	2	JAN	0545	72	.00	.00	.00	0.
1	JAN	1345	8	.00	.00	.00	0.	*	2	JAN	0600	73	.00	.00	.00	0.
1	JAN	1400	9	.00	.00	.00	0.	*	2	JAN	0615	74	.00	.00	.00	0.
1	JAN	1415	10	.00	.00	.00	0.	*	2	JAN	0630	75	.00	.00	.00	0.
1	JAN	1430	11	.00	.00	.00	0.	*	2	JAN	0645	76	.00	.00	.00	0.
1	JAN	1445	12	.00	.00	.00	0.	*	2	JAN	0700	77	.00	.00	.00	0.
1	JAN	1500	13	.00	.00	.00	0.	*	2	JAN	0715	78	.00	.00	.00	0.
1	JAN	1515	14	.00	.00	.00	0.	*	2	JAN	0730	79	.00	.00	.00	0.
1	JAN	1530	15	.00	.00	.00	0.	*	2	JAN	0745	80	.00	.00	.00	0.
1	JAN	1545	16	.00	.00	.00	0.	*	2	JAN	0800	81	.00	.00	.00	0.
1	JAN	1600	17	.00	.00	.00	0.	*	2	JAN	0815	82	.00	.00	.00	0.
1	JAN	1615	18	.00	.00	.00	0.	*	2	JAN	0830	83	.00	.00	.00	0.
1	JAN	1630	19	.00	.00	.00	0.	*	2	JAN	0845	84	.00	.00	.00	0.
1	JAN	1645	20	.00	.00	.00	0.	*	2	JAN	0900	85	.00	.00	.00	0.
1	JAN	1700	21	.00	.00	.00	0.	*	2	JAN	0915	86	.00	.00	.00	0.
1	JAN	1715	22	.00	.00	.00	0.	*	2	JAN	0930	87	.00	.00	.00	0.

1 JAN 1730	23	.00	.00	.00	0.	*	2 JAN 0945	88	.00	.00	.00	0.
1 JAN 1745	24	.00	.00	.00	0.	*	2 JAN 1000	89	.00	.00	.00	0.
1 JAN 1800	25	.00	.00	.00	0.	*	2 JAN 1015	90	.00	.00	.00	0.
1 JAN 1815	26	.01	.00	.00	0.	*	2 JAN 1030	91	.00	.00	.00	0.
1 JAN 1830	27	.01	.00	.00	0.	*	2 JAN 1045	92	.00	.00	.00	0.
1 JAN 1845	28	.00	.00	.00	0.	*	2 JAN 1100	93	.00	.00	.00	0.
1 JAN 1900	29	.01	.00	.00	0.	*	2 JAN 1115	94	.00	.00	.00	0.
1 JAN 1915	30	.00	.00	.00	0.	*	2 JAN 1130	95	.00	.00	.00	0.
1 JAN 1930	31	.01	.00	.00	0.	*	2 JAN 1145	96	.00	.00	.00	0.
1 JAN 1945	32	.01	.00	.00	0.	*	2 JAN 1200	97	.00	.00	.00	0.
1 JAN 2000	33	.00	.00	.00	0.	*	2 JAN 1215	98	.00	.00	.00	0.
1 JAN 2015	34	.01	.01	.00	0.	*	2 JAN 1230	99	.00	.00	.00	0.
1 JAN 2030	35	.01	.01	.00	0.	*	2 JAN 1245	100	.00	.00	.00	0.
1 JAN 2045	36	.01	.01	.00	0.	*	2 JAN 1300	101	.00	.00	.00	0.
1 JAN 2100	37	.01	.01	.00	0.	*	2 JAN 1315	102	.00	.00	.00	0.
1 JAN 2115	38	.01	.01	.00	0.	*	2 JAN 1330	103	.00	.00	.00	0.
1 JAN 2130	39	.01	.01	.00	0.	*	2 JAN 1345	104	.00	.00	.00	0.
1 JAN 2145	40	.01	.01	.00	0.	*	2 JAN 1400	105	.00	.00	.00	0.
1 JAN 2200	41	.01	.01	.00	0.	*	2 JAN 1415	106	.00	.00	.00	0.
1 JAN 2215	42	.01	.01	.00	0.	*	2 JAN 1430	107	.00	.00	.00	0.
1 JAN 2230	43	.01	.01	.00	0.	*	2 JAN 1445	108	.00	.00	.00	0.
1 JAN 2245	44	.02	.01	.00	0.	*	2 JAN 1500	109	.00	.00	.00	0.
1 JAN 2300	45	.02	.01	.00	0.	*	2 JAN 1515	110	.00	.00	.00	0.
1 JAN 2315	46	.02	.02	.00	0.	*	2 JAN 1530	111	.00	.00	.00	0.
1 JAN 2330	47	.02	.02	.00	0.	*	2 JAN 1545	112	.00	.00	.00	0.
1 JAN 2345	48	.10	.09	.01	0.	*	2 JAN 1600	113	.00	.00	.00	0.
2 JAN 0000	49	.28	.25	.03	0.	*	2 JAN 1615	114	.00	.00	.00	0.
2 JAN 0015	50	.04	.03	.00	0.	*	2 JAN 1630	115	.00	.00	.00	0.
2 JAN 0030	51	.04	.03	.00	0.	*	2 JAN 1645	116	.00	.00	.00	0.
2 JAN 0045	52	.02	.02	.00	0.	*	2 JAN 1700	117	.00	.00	.00	0.
2 JAN 0100	53	.02	.02	.00	0.	*	2 JAN 1715	118	.00	.00	.00	0.
2 JAN 0115	54	.01	.01	.00	0.	*	2 JAN 1730	119	.00	.00	.00	0.
2 JAN 0130	55	.01	.01	.00	0.	*	2 JAN 1745	120	.00	.00	.00	0.
2 JAN 0145	56	.01	.01	.00	0.	*	2 JAN 1800	121	.00	.00	.00	0.
2 JAN 0200	57	.01	.01	.00	0.	*	2 JAN 1815	122	.00	.00	.00	0.
2 JAN 0215	58	.01	.01	.00	0.	*	2 JAN 1830	123	.00	.00	.00	0.
2 JAN 0230	59	.01	.01	.00	0.	*	2 JAN 1845	124	.00	.00	.00	0.
2 JAN 0245	60	.01	.01	.00	0.	*	2 JAN 1900	125	.00	.00	.00	0.
2 JAN 0300	61	.01	.01	.00	0.	*	2 JAN 1915	126	.00	.00	.00	0.
2 JAN 0315	62	.01	.01	.00	0.	*	2 JAN 1930	127	.00	.00	.00	0.
2 JAN 0330	63	.01	.01	.00	0.	*	2 JAN 1945	128	.00	.00	.00	0.
2 JAN 0345	64	.01	.01	.00	0.	*	2 JAN 2000	129	.00	.00	.00	0.
2 JAN 0400	65	.01	.01	.00	0.	*						

TOTAL RAINFALL = 1.00, TOTAL LOSS = .90, TOTAL EXCESS = .10

PEAK FLOW + (CFS)	TIME (HR)	MAXIMUM AVERAGE FLOW			
		6-HR	24-HR	72-HR	32.00-HR
0.	12.00	0.	0.	0.	0.
	(INCHES)	.070	.100	.101	.101
	(AC-FT)	0.	0.	0.	0.

CUMULATIVE AREA = .00 SQ MI

WARNING *** TIME INTERVAL IS GREATER THAN .29*LAG

HYDROGRAPH AT STATION BSNA
 PLAN 1, RATIO = 7.80

DA	MON	HRMN	ORD	RAIN	LOSS	EXCESS	COMP Q	*	DA	MON	HRMN	ORD	RAIN	LOSS	EXCESS	COMP Q
1	JAN	1200	1	.00	.00	.00	0.	*	2	JAN	0415	66	.04	.01	.03	1.
1	JAN	1215	2	.02	.02	.00	0.	*	2	JAN	0430	67	.03	.01	.03	0.
1	JAN	1230	3	.02	.02	.00	0.	*	2	JAN	0445	68	.04	.01	.03	0.
1	JAN	1245	4	.02	.01	.00	0.	*	2	JAN	0500	69	.03	.01	.03	0.
1	JAN	1300	5	.02	.02	.00	0.	*	2	JAN	0515	70	.04	.01	.03	0.
1	JAN	1315	6	.02	.02	.00	0.	*	2	JAN	0530	71	.03	.01	.03	0.
1	JAN	1330	7	.02	.02	.00	0.	*	2	JAN	0545	72	.04	.01	.03	0.
1	JAN	1345	8	.02	.01	.00	0.	*	2	JAN	0600	73	.03	.01	.03	0.
1	JAN	1400	9	.02	.02	.00	0.	*	2	JAN	0615	74	.04	.01	.03	0.
1	JAN	1415	10	.02	.02	.00	0.	*	2	JAN	0630	75	.03	.01	.03	0.
1	JAN	1430	11	.03	.03	.00	0.	*	2	JAN	0645	76	.03	.01	.03	0.
1	JAN	1445	12	.02	.02	.00	0.	*	2	JAN	0700	77	.04	.01	.03	0.
1	JAN	1500	13	.02	.02	.00	0.	*	2	JAN	0715	78	.03	.01	.03	0.
1	JAN	1515	14	.02	.02	.00	0.	*	2	JAN	0730	79	.04	.01	.03	0.
1	JAN	1530	15	.03	.03	.00	0.	*	2	JAN	0745	80	.03	.01	.03	0.
1	JAN	1545	16	.02	.02	.00	0.	*	2	JAN	0800	81	.04	.01	.03	0.
1	JAN	1600	17	.02	.02	.00	0.	*	2	JAN	0815	82	.02	.00	.02	0.
1	JAN	1615	18	.03	.03	.00	0.	*	2	JAN	0830	83	.02	.00	.02	0.
1	JAN	1630	19	.03	.03	.00	0.	*	2	JAN	0845	84	.02	.00	.02	0.
1	JAN	1645	20	.03	.03	.00	0.	*	2	JAN	0900	85	.02	.00	.02	0.
1	JAN	1700	21	.03	.03	.00	0.	*	2	JAN	0915	86	.02	.00	.02	0.
1	JAN	1715	22	.03	.03	.00	0.	*	2	JAN	0930	87	.02	.00	.02	0.
1	JAN	1730	23	.03	.03	.00	0.	*	2	JAN	0945	88	.02	.00	.02	0.
1	JAN	1745	24	.03	.03	.00	0.	*	2	JAN	1000	89	.02	.00	.02	0.
1	JAN	1800	25	.03	.03	.00	0.	*	2	JAN	1015	90	.02	.00	.02	0.
1	JAN	1815	26	.04	.04	.00	0.	*	2	JAN	1030	91	.02	.00	.02	0.
1	JAN	1830	27	.04	.04	.00	0.	*	2	JAN	1045	92	.02	.00	.02	0.
1	JAN	1845	28	.04	.04	.00	0.	*	2	JAN	1100	93	.02	.00	.02	0.
1	JAN	1900	29	.04	.04	.00	0.	*	2	JAN	1115	94	.02	.00	.02	0.
1	JAN	1915	30	.04	.04	.00	0.	*	2	JAN	1130	95	.02	.00	.02	0.
1	JAN	1930	31	.04	.04	.00	0.	*	2	JAN	1145	96	.02	.00	.02	0.
1	JAN	1945	32	.04	.04	.00	0.	*	2	JAN	1200	97	.02	.00	.02	0.
1	JAN	2000	33	.04	.04	.00	0.	*	2	JAN	1215	98	.00	.00	.00	0.
1	JAN	2015	34	.05	.05	.01	0.	*	2	JAN	1230	99	.00	.00	.00	0.
1	JAN	2030	35	.05	.05	.01	0.	*	2	JAN	1245	100	.00	.00	.00	0.
1	JAN	2045	36	.05	.04	.01	0.	*	2	JAN	1300	101	.00	.00	.00	0.
1	JAN	2100	37	.05	.05	.01	0.	*	2	JAN	1315	102	.00	.00	.00	0.
1	JAN	2115	38	.06	.05	.01	0.	*	2	JAN	1330	103	.00	.00	.00	0.
1	JAN	2130	39	.06	.05	.01	0.	*	2	JAN	1345	104	.00	.00	.00	0.
1	JAN	2145	40	.07	.05	.02	0.	*	2	JAN	1400	105	.00	.00	.00	0.
1	JAN	2200	41	.07	.05	.02	0.	*	2	JAN	1415	106	.00	.00	.00	0.
1	JAN	2215	42	.09	.07	.03	0.	*	2	JAN	1430	107	.00	.00	.00	0.
1	JAN	2230	43	.09	.06	.03	0.	*	2	JAN	1445	108	.00	.00	.00	0.
1	JAN	2245	44	.12	.08	.04	0.	*	2	JAN	1500	109	.00	.00	.00	0.
1	JAN	2300	45	.12	.08	.04	0.	*	2	JAN	1515	110	.00	.00	.00	0.
1	JAN	2315	46	.19	.12	.07	1.	*	2	JAN	1530	111	.00	.00	.00	0.
1	JAN	2330	47	.19	.11	.08	1.	*	2	JAN	1545	112	.00	.00	.00	0.
1	JAN	2345	48	.81	.40	.41	3.	*	2	JAN	1600	113	.00	.00	.00	0.
2	JAN	0000	49	2.15	.71	1.44	11.	*	2	JAN	1615	114	.00	.00	.00	0.
2	JAN	0015	50	.28	.07	.21	9.	*	2	JAN	1630	115	.00	.00	.00	0.

2 JAN 0030	51	.28	.06	.22	4.	*	2 JAN 1645	116	.00	.00	.00	0.
2 JAN 0045	52	.15	.03	.12	3.	*	2 JAN 1700	117	.00	.00	.00	0.
2 JAN 0100	53	.14	.03	.11	2.	*	2 JAN 1715	118	.00	.00	.00	0.
2 JAN 0115	54	.11	.02	.09	1.	*	2 JAN 1730	119	.00	.00	.00	0.
2 JAN 0130	55	.10	.02	.08	1.	*	2 JAN 1745	120	.00	.00	.00	0.
2 JAN 0145	56	.09	.02	.07	1.	*	2 JAN 1800	121	.00	.00	.00	0.
2 JAN 0200	57	.08	.02	.06	1.	*	2 JAN 1815	122	.00	.00	.00	0.
2 JAN 0215	58	.06	.01	.05	1.	*	2 JAN 1830	123	.00	.00	.00	0.
2 JAN 0230	59	.05	.01	.04	1.	*	2 JAN 1845	124	.00	.00	.00	0.
2 JAN 0245	60	.06	.01	.05	1.	*	2 JAN 1900	125	.00	.00	.00	0.
2 JAN 0300	61	.05	.01	.04	1.	*	2 JAN 1915	126	.00	.00	.00	0.
2 JAN 0315	62	.06	.01	.05	1.	*	2 JAN 1930	127	.00	.00	.00	0.
2 JAN 0330	63	.05	.01	.04	1.	*	2 JAN 1945	128	.00	.00	.00	0.
2 JAN 0345	64	.06	.01	.05	1.	*	2 JAN 2000	129	.00	.00	.00	0.
2 JAN 0400	65	.05	.01	.04	1.	*						

TOTAL RAINFALL = 7.80, TOTAL LOSS = 3.36, TOTAL EXCESS = 4.44

PEAK FLOW (CFS)	TIME (HR)	MAXIMUM AVERAGE FLOW			
		6-HR	24-HR	72-HR	32.00-HR
11.	12.00	2.	1.	0.	0.
	(INCHES)	3.481	4.437	4.441	4.441
	(AC-FT)	1.	1.	1.	1.

CUMULATIVE AREA = .00 SQ MI

*** **

* *
23 KK * BSNB *
* *

5 IN TIME DATA FOR INPUT TIME SERIES
JXMIN 15 TIME INTERVAL IN MINUTES
JXDATE 1JAN 3 STARTING DATE
JXTIME 1200 STARTING TIME

SUBBASIN RUNOFF DATA

24 BA SUBBASIN CHARACTERISTICS
TAREA .00 SUBBASIN AREA

PRECIPITATION DATA

PB STORM 1.00 BASIN TOTAL PRECIPITATION

26 PI INCREMENTAL PRECIPITATION PATTERN

.00	.00	.00	.00	.00	.00	.00	.00	.00	.00	.00
.00	.00	.00	.00	.00	.00	.00	.00	.00	.00	.00
.00	.00	.00	.00	.01	.01	.00	.01	.00	.01	.01

.01	.00	.01	.01	.01	.01	.01	.01	.01	.01
.01	.01	.02	.02	.02	.02	.10	.28	.04	.04
.02	.02	.01	.01	.01	.01	.01	.01	.01	.01
.01	.01	.01	.01	.00	.00	.00	.00	.00	.00
.00	.00	.00	.00	.00	.00	.00	.00	.00	.00
.00	.00	.00	.00	.00	.00	.00	.00	.00	.00
.00	.00	.00	.00	.00	.00	.00	.00	.00	.00

36 LS SCS LOSS RATE
 STRTL .94 INITIAL ABSTRACTION
 CRVNBR 68.00 CURVE NUMBER
 RTIMP 10.00 PERCENT IMPERVIOUS AREA

37 UD SCS DIMENSIONLESS UNITGRAPH
 TLAG .12 LAG

WARNING *** TIME INTERVAL IS GREATER THAN .29*LAG

UNIT HYDROGRAPH
 5 END-OF-PERIOD ORDINATES

2. 1. 0. 0. 0.

HYDROGRAPH AT STATION BSNB

DA	MON	HRMN	ORD	RAIN	LOSS	EXCESS	COMP	Q	*	DA	MON	HRMN	ORD	RAIN	LOSS	EXCESS	COMP	Q
1	JAN	1200	1	.00	.00	.00	0.	*		2	JAN	0415	66	.00	.00	.00	0.	*
1	JAN	1215	2	.00	.00	.00	0.	*		2	JAN	0430	67	.00	.00	.00	0.	*
1	JAN	1230	3	.00	.00	.00	0.	*		2	JAN	0445	68	.00	.00	.00	0.	*
1	JAN	1245	4	.00	.00	.00	0.	*		2	JAN	0500	69	.00	.00	.00	0.	*
1	JAN	1300	5	.00	.00	.00	0.	*		2	JAN	0515	70	.00	.00	.00	0.	*
1	JAN	1315	6	.00	.00	.00	0.	*		2	JAN	0530	71	.00	.00	.00	0.	*
1	JAN	1330	7	.00	.00	.00	0.	*		2	JAN	0545	72	.00	.00	.00	0.	*
1	JAN	1345	8	.00	.00	.00	0.	*		2	JAN	0600	73	.00	.00	.00	0.	*
1	JAN	1400	9	.00	.00	.00	0.	*		2	JAN	0615	74	.00	.00	.00	0.	*
1	JAN	1415	10	.00	.00	.00	0.	*		2	JAN	0630	75	.00	.00	.00	0.	*
1	JAN	1430	11	.00	.00	.00	0.	*		2	JAN	0645	76	.00	.00	.00	0.	*
1	JAN	1445	12	.00	.00	.00	0.	*		2	JAN	0700	77	.00	.00	.00	0.	*
1	JAN	1500	13	.00	.00	.00	0.	*		2	JAN	0715	78	.00	.00	.00	0.	*
1	JAN	1515	14	.00	.00	.00	0.	*		2	JAN	0730	79	.00	.00	.00	0.	*
1	JAN	1530	15	.00	.00	.00	0.	*		2	JAN	0745	80	.00	.00	.00	0.	*
1	JAN	1545	16	.00	.00	.00	0.	*		2	JAN	0800	81	.00	.00	.00	0.	*
1	JAN	1600	17	.00	.00	.00	0.	*		2	JAN	0815	82	.00	.00	.00	0.	*
1	JAN	1615	18	.00	.00	.00	0.	*		2	JAN	0830	83	.00	.00	.00	0.	*
1	JAN	1630	19	.00	.00	.00	0.	*		2	JAN	0845	84	.00	.00	.00	0.	*
1	JAN	1645	20	.00	.00	.00	0.	*		2	JAN	0900	85	.00	.00	.00	0.	*
1	JAN	1700	21	.00	.00	.00	0.	*		2	JAN	0915	86	.00	.00	.00	0.	*
1	JAN	1715	22	.00	.00	.00	0.	*		2	JAN	0930	87	.00	.00	.00	0.	*
1	JAN	1730	23	.00	.00	.00	0.	*		2	JAN	0945	88	.00	.00	.00	0.	*
1	JAN	1745	24	.00	.00	.00	0.	*		2	JAN	1000	89	.00	.00	.00	0.	*
1	JAN	1800	25	.00	.00	.00	0.	*		2	JAN	1015	90	.00	.00	.00	0.	*
1	JAN	1815	26	.01	.00	.00	0.	*		2	JAN	1030	91	.00	.00	.00	0.	*
1	JAN	1830	27	.01	.00	.00	0.	*		2	JAN	1045	92	.00	.00	.00	0.	*
1	JAN	1845	28	.00	.00	.00	0.	*		2	JAN	1100	93	.00	.00	.00	0.	*

1 JAN 1900	29	.01	.00	.00	0.	*	2 JAN 1115	94	.00	.00	.00	0.
1 JAN 1915	30	.00	.00	.00	0.	*	2 JAN 1130	95	.00	.00	.00	0.
1 JAN 1930	31	.01	.00	.00	0.	*	2 JAN 1145	96	.00	.00	.00	0.
1 JAN 1945	32	.01	.00	.00	0.	*	2 JAN 1200	97	.00	.00	.00	0.
1 JAN 2000	33	.00	.00	.00	0.	*	2 JAN 1215	98	.00	.00	.00	0.
1 JAN 2015	34	.01	.01	.00	0.	*	2 JAN 1230	99	.00	.00	.00	0.
1 JAN 2030	35	.01	.01	.00	0.	*	2 JAN 1245	100	.00	.00	.00	0.
1 JAN 2045	36	.01	.01	.00	0.	*	2 JAN 1300	101	.00	.00	.00	0.
1 JAN 2100	37	.01	.01	.00	0.	*	2 JAN 1315	102	.00	.00	.00	0.
1 JAN 2115	38	.01	.01	.00	0.	*	2 JAN 1330	103	.00	.00	.00	0.
1 JAN 2130	39	.01	.01	.00	0.	*	2 JAN 1345	104	.00	.00	.00	0.
1 JAN 2145	40	.01	.01	.00	0.	*	2 JAN 1400	105	.00	.00	.00	0.
1 JAN 2200	41	.01	.01	.00	0.	*	2 JAN 1415	106	.00	.00	.00	0.
1 JAN 2215	42	.01	.01	.00	0.	*	2 JAN 1430	107	.00	.00	.00	0.
1 JAN 2230	43	.01	.01	.00	0.	*	2 JAN 1445	108	.00	.00	.00	0.
1 JAN 2245	44	.02	.01	.00	0.	*	2 JAN 1500	109	.00	.00	.00	0.
1 JAN 2300	45	.02	.01	.00	0.	*	2 JAN 1515	110	.00	.00	.00	0.
1 JAN 2315	46	.02	.02	.00	0.	*	2 JAN 1530	111	.00	.00	.00	0.
1 JAN 2330	47	.02	.02	.00	0.	*	2 JAN 1545	112	.00	.00	.00	0.
1 JAN 2345	48	.10	.09	.01	0.	*	2 JAN 1600	113	.00	.00	.00	0.
2 JAN 0000	49	.28	.25	.03	0.	*	2 JAN 1615	114	.00	.00	.00	0.
2 JAN 0015	50	.04	.03	.00	0.	*	2 JAN 1630	115	.00	.00	.00	0.
2 JAN 0030	51	.04	.03	.00	0.	*	2 JAN 1645	116	.00	.00	.00	0.
2 JAN 0045	52	.02	.02	.00	0.	*	2 JAN 1700	117	.00	.00	.00	0.
2 JAN 0100	53	.02	.02	.00	0.	*	2 JAN 1715	118	.00	.00	.00	0.
2 JAN 0115	54	.01	.01	.00	0.	*	2 JAN 1730	119	.00	.00	.00	0.
2 JAN 0130	55	.01	.01	.00	0.	*	2 JAN 1745	120	.00	.00	.00	0.
2 JAN 0145	56	.01	.01	.00	0.	*	2 JAN 1800	121	.00	.00	.00	0.
2 JAN 0200	57	.01	.01	.00	0.	*	2 JAN 1815	122	.00	.00	.00	0.
2 JAN 0215	58	.01	.01	.00	0.	*	2 JAN 1830	123	.00	.00	.00	0.
2 JAN 0230	59	.01	.01	.00	0.	*	2 JAN 1845	124	.00	.00	.00	0.
2 JAN 0245	60	.01	.01	.00	0.	*	2 JAN 1900	125	.00	.00	.00	0.
2 JAN 0300	61	.01	.01	.00	0.	*	2 JAN 1915	126	.00	.00	.00	0.
2 JAN 0315	62	.01	.01	.00	0.	*	2 JAN 1930	127	.00	.00	.00	0.
2 JAN 0330	63	.01	.01	.00	0.	*	2 JAN 1945	128	.00	.00	.00	0.
2 JAN 0345	64	.01	.01	.00	0.	*	2 JAN 2000	129	.00	.00	.00	0.
2 JAN 0400	65	.01	.01	.00	0.	*						

TOTAL RAINFALL = 1.00, TOTAL LOSS = .90, TOTAL EXCESS = .10

PEAK FLOW (CFS)	TIME (HR)	MAXIMUM AVERAGE FLOW				
		6-HR	24-HR	72-HR	32.00-HR	
0.	12.00	0.	0.	0.	0.	
		(INCHES)	.070	.100	.101	.101
		(AC-FT)	0.	0.	0.	0.

CUMULATIVE AREA = .00 SQ MI

WARNING *** TIME INTERVAL IS GREATER THAN .29*LAG

HYDROGRAPH AT STATION BSNB
PLAN 1, RATIO = 7.80

DA	MON	HRMN	ORD	RAIN	LOSS	EXCESS	COMP	Q	*	DA	MON	HRMN	ORD	RAIN	LOSS	EXCESS	COMP	Q
1	JAN	1200	1	.00	.00	.00	0.	*	*	2	JAN	0415	66	.04	.01	.03	0.	*
1	JAN	1215	2	.02	.02	.00	0.	*	*	2	JAN	0430	67	.03	.01	.03	0.	*
1	JAN	1230	3	.02	.02	.00	0.	*	*	2	JAN	0445	68	.04	.01	.03	0.	*
1	JAN	1245	4	.02	.01	.00	0.	*	*	2	JAN	0500	69	.03	.01	.03	0.	*
1	JAN	1300	5	.02	.02	.00	0.	*	*	2	JAN	0515	70	.04	.01	.03	0.	*
1	JAN	1315	6	.02	.02	.00	0.	*	*	2	JAN	0530	71	.03	.01	.03	0.	*
1	JAN	1330	7	.02	.02	.00	0.	*	*	2	JAN	0545	72	.04	.01	.03	0.	*
1	JAN	1345	8	.02	.01	.00	0.	*	*	2	JAN	0600	73	.03	.01	.03	0.	*
1	JAN	1400	9	.02	.02	.00	0.	*	*	2	JAN	0615	74	.04	.01	.03	0.	*
1	JAN	1415	10	.02	.02	.00	0.	*	*	2	JAN	0630	75	.03	.01	.03	0.	*
1	JAN	1430	11	.03	.03	.00	0.	*	*	2	JAN	0645	76	.03	.01	.03	0.	*
1	JAN	1445	12	.02	.02	.00	0.	*	*	2	JAN	0700	77	.04	.01	.03	0.	*
1	JAN	1500	13	.02	.02	.00	0.	*	*	2	JAN	0715	78	.03	.01	.03	0.	*
1	JAN	1515	14	.02	.02	.00	0.	*	*	2	JAN	0730	79	.04	.01	.03	0.	*
1	JAN	1530	15	.03	.03	.00	0.	*	*	2	JAN	0745	80	.03	.01	.03	0.	*
1	JAN	1545	16	.02	.02	.00	0.	*	*	2	JAN	0800	81	.04	.01	.03	0.	*
1	JAN	1600	17	.02	.02	.00	0.	*	*	2	JAN	0815	82	.02	.00	.02	0.	*
1	JAN	1615	18	.03	.03	.00	0.	*	*	2	JAN	0830	83	.02	.00	.02	0.	*
1	JAN	1630	19	.03	.03	.00	0.	*	*	2	JAN	0845	84	.02	.00	.02	0.	*
1	JAN	1645	20	.03	.03	.00	0.	*	*	2	JAN	0900	85	.02	.00	.02	0.	*
1	JAN	1700	21	.03	.03	.00	0.	*	*	2	JAN	0915	86	.02	.00	.02	0.	*
1	JAN	1715	22	.03	.03	.00	0.	*	*	2	JAN	0930	87	.02	.00	.02	0.	*
1	JAN	1730	23	.03	.03	.00	0.	*	*	2	JAN	0945	88	.02	.00	.02	0.	*
1	JAN	1745	24	.03	.03	.00	0.	*	*	2	JAN	1000	89	.02	.00	.02	0.	*
1	JAN	1800	25	.03	.03	.00	0.	*	*	2	JAN	1015	90	.02	.00	.02	0.	*
1	JAN	1815	26	.04	.04	.00	0.	*	*	2	JAN	1030	91	.02	.00	.02	0.	*
1	JAN	1830	27	.04	.04	.00	0.	*	*	2	JAN	1045	92	.02	.00	.02	0.	*
1	JAN	1845	28	.04	.04	.00	0.	*	*	2	JAN	1100	93	.02	.00	.02	0.	*
1	JAN	1900	29	.04	.04	.00	0.	*	*	2	JAN	1115	94	.02	.00	.02	0.	*
1	JAN	1915	30	.04	.04	.00	0.	*	*	2	JAN	1130	95	.02	.00	.02	0.	*
1	JAN	1930	31	.04	.04	.00	0.	*	*	2	JAN	1145	96	.02	.00	.02	0.	*
1	JAN	1945	32	.04	.04	.00	0.	*	*	2	JAN	1200	97	.02	.00	.02	0.	*
1	JAN	2000	33	.04	.04	.00	0.	*	*	2	JAN	1215	98	.00	.00	.00	0.	*
1	JAN	2015	34	.05	.05	.01	0.	*	*	2	JAN	1230	99	.00	.00	.00	0.	*
1	JAN	2030	35	.05	.05	.01	0.	*	*	2	JAN	1245	100	.00	.00	.00	0.	*
1	JAN	2045	36	.05	.04	.01	0.	*	*	2	JAN	1300	101	.00	.00	.00	0.	*
1	JAN	2100	37	.05	.05	.01	0.	*	*	2	JAN	1315	102	.00	.00	.00	0.	*
1	JAN	2115	38	.06	.05	.01	0.	*	*	2	JAN	1330	103	.00	.00	.00	0.	*
1	JAN	2130	39	.06	.05	.01	0.	*	*	2	JAN	1345	104	.00	.00	.00	0.	*
1	JAN	2145	40	.07	.05	.02	0.	*	*	2	JAN	1400	105	.00	.00	.00	0.	*
1	JAN	2200	41	.07	.05	.02	0.	*	*	2	JAN	1415	106	.00	.00	.00	0.	*
1	JAN	2215	42	.09	.07	.03	0.	*	*	2	JAN	1430	107	.00	.00	.00	0.	*
1	JAN	2230	43	.09	.06	.03	0.	*	*	2	JAN	1445	108	.00	.00	.00	0.	*
1	JAN	2245	44	.12	.08	.04	0.	*	*	2	JAN	1500	109	.00	.00	.00	0.	*
1	JAN	2300	45	.12	.08	.04	0.	*	*	2	JAN	1515	110	.00	.00	.00	0.	*
1	JAN	2315	46	.19	.12	.07	0.	*	*	2	JAN	1530	111	.00	.00	.00	0.	*
1	JAN	2330	47	.19	.11	.08	0.	*	*	2	JAN	1545	112	.00	.00	.00	0.	*
1	JAN	2345	48	.81	.40	.41	1.	*	*	2	JAN	1600	113	.00	.00	.00	0.	*
2	JAN	0000	49	2.15	.71	1.44	3.	*	*	2	JAN	1615	114	.00	.00	.00	0.	*
2	JAN	0015	50	.28	.07	.21	1.	*	*	2	JAN	1630	115	.00	.00	.00	0.	*
2	JAN	0030	51	.28	.06	.22	1.	*	*	2	JAN	1645	116	.00	.00	.00	0.	*
2	JAN	0045	52	.15	.03	.12	0.	*	*	2	JAN	1700	117	.00	.00	.00	0.	*
2	JAN	0100	53	.14	.03	.11	0.	*	*	2	JAN	1715	118	.00	.00	.00	0.	*
2	JAN	0115	54	.11	.02	.09	0.	*	*	2	JAN	1730	119	.00	.00	.00	0.	*
2	JAN	0130	55	.10	.02	.08	0.	*	*	2	JAN	1745	120	.00	.00	.00	0.	*
2	JAN	0145	56	.09	.02	.07	0.	*	*	2	JAN	1800	121	.00	.00	.00	0.	*

.00 .00 .00 .00 .00 .00

51 LS

SCS LOSS RATE

STRTL .94 INITIAL ABSTRACTION
CRVNB 68.00 CURVE NUMBER
RTIMP 10.00 PERCENT IMPERVIOUS AREA

52 UD

SCS DIMENSIONLESS UNITGRAPH

TLAG .20 LAG

WARNING *** TIME INTERVAL IS GREATER THAN .29*LAG

UNIT HYDROGRAPH
6 END-OF-PERIOD ORDINATES

9. 6. 2. 1. 0. 0.

HYDROGRAPH AT STATION BSND

DA	MON	HRMN	ORD	RAIN	LOSS	EXCESS	COMP	Q	*	DA	MON	HRMN	ORD	RAIN	LOSS	EXCESS	COMP	Q
1	JAN	1200	1	.00	.00	.00	0.	*		2	JAN	0415	66	.00	.00	.00	0.	*
1	JAN	1215	2	.00	.00	.00	0.	*		2	JAN	0430	67	.00	.00	.00	0.	*
1	JAN	1230	3	.00	.00	.00	0.	*		2	JAN	0445	68	.00	.00	.00	0.	*
1	JAN	1245	4	.00	.00	.00	0.	*		2	JAN	0500	69	.00	.00	.00	0.	*
1	JAN	1300	5	.00	.00	.00	0.	*		2	JAN	0515	70	.00	.00	.00	0.	*
1	JAN	1315	6	.00	.00	.00	0.	*		2	JAN	0530	71	.00	.00	.00	0.	*
1	JAN	1330	7	.00	.00	.00	0.	*		2	JAN	0545	72	.00	.00	.00	0.	*
1	JAN	1345	8	.00	.00	.00	0.	*		2	JAN	0600	73	.00	.00	.00	0.	*
1	JAN	1400	9	.00	.00	.00	0.	*		2	JAN	0615	74	.00	.00	.00	0.	*
1	JAN	1415	10	.00	.00	.00	0.	*		2	JAN	0630	75	.00	.00	.00	0.	*
1	JAN	1430	11	.00	.00	.00	0.	*		2	JAN	0645	76	.00	.00	.00	0.	*
1	JAN	1445	12	.00	.00	.00	0.	*		2	JAN	0700	77	.00	.00	.00	0.	*
1	JAN	1500	13	.00	.00	.00	0.	*		2	JAN	0715	78	.00	.00	.00	0.	*
1	JAN	1515	14	.00	.00	.00	0.	*		2	JAN	0730	79	.00	.00	.00	0.	*
1	JAN	1530	15	.00	.00	.00	0.	*		2	JAN	0745	80	.00	.00	.00	0.	*
1	JAN	1545	16	.00	.00	.00	0.	*		2	JAN	0800	81	.00	.00	.00	0.	*
1	JAN	1600	17	.00	.00	.00	0.	*		2	JAN	0815	82	.00	.00	.00	0.	*
1	JAN	1615	18	.00	.00	.00	0.	*		2	JAN	0830	83	.00	.00	.00	0.	*
1	JAN	1630	19	.00	.00	.00	0.	*		2	JAN	0845	84	.00	.00	.00	0.	*
1	JAN	1645	20	.00	.00	.00	0.	*		2	JAN	0900	85	.00	.00	.00	0.	*
1	JAN	1700	21	.00	.00	.00	0.	*		2	JAN	0915	86	.00	.00	.00	0.	*
1	JAN	1715	22	.00	.00	.00	0.	*		2	JAN	0930	87	.00	.00	.00	0.	*
1	JAN	1730	23	.00	.00	.00	0.	*		2	JAN	0945	88	.00	.00	.00	0.	*
1	JAN	1745	24	.00	.00	.00	0.	*		2	JAN	1000	89	.00	.00	.00	0.	*
1	JAN	1800	25	.00	.00	.00	0.	*		2	JAN	1015	90	.00	.00	.00	0.	*
1	JAN	1815	26	.01	.00	.00	0.	*		2	JAN	1030	91	.00	.00	.00	0.	*
1	JAN	1830	27	.01	.00	.00	0.	*		2	JAN	1045	92	.00	.00	.00	0.	*
1	JAN	1845	28	.00	.00	.00	0.	*		2	JAN	1100	93	.00	.00	.00	0.	*
1	JAN	1900	29	.01	.00	.00	0.	*		2	JAN	1115	94	.00	.00	.00	0.	*
1	JAN	1915	30	.00	.00	.00	0.	*		2	JAN	1130	95	.00	.00	.00	0.	*
1	JAN	1930	31	.01	.00	.00	0.	*		2	JAN	1145	96	.00	.00	.00	0.	*
1	JAN	1945	32	.01	.00	.00	0.	*		2	JAN	1200	97	.00	.00	.00	0.	*
1	JAN	2000	33	.00	.00	.00	0.	*		2	JAN	1215	98	.00	.00	.00	0.	*
1	JAN	2015	34	.01	.01	.00	0.	*		2	JAN	1230	99	.00	.00	.00	0.	*

1 JAN 2030	35	.01	.01	.00	0.	*	2 JAN 1245	100	.00	.00	.00	0.
1 JAN 2045	36	.01	.01	.00	0.	*	2 JAN 1300	101	.00	.00	.00	0.
1 JAN 2100	37	.01	.01	.00	0.	*	2 JAN 1315	102	.00	.00	.00	0.
1 JAN 2115	38	.01	.01	.00	0.	*	2 JAN 1330	103	.00	.00	.00	0.
1 JAN 2130	39	.01	.01	.00	0.	*	2 JAN 1345	104	.00	.00	.00	0.
1 JAN 2145	40	.01	.01	.00	0.	*	2 JAN 1400	105	.00	.00	.00	0.
1 JAN 2200	41	.01	.01	.00	0.	*	2 JAN 1415	106	.00	.00	.00	0.
1 JAN 2215	42	.01	.01	.00	0.	*	2 JAN 1430	107	.00	.00	.00	0.
1 JAN 2230	43	.01	.01	.00	0.	*	2 JAN 1445	108	.00	.00	.00	0.
1 JAN 2245	44	.02	.01	.00	0.	*	2 JAN 1500	109	.00	.00	.00	0.
1 JAN 2300	45	.02	.01	.00	0.	*	2 JAN 1515	110	.00	.00	.00	0.
1 JAN 2315	46	.02	.02	.00	0.	*	2 JAN 1530	111	.00	.00	.00	0.
1 JAN 2330	47	.02	.02	.00	0.	*	2 JAN 1545	112	.00	.00	.00	0.
1 JAN 2345	48	.10	.09	.01	0.	*	2 JAN 1600	113	.00	.00	.00	0.
2 JAN 0000	49	.28	.25	.03	0.	*	2 JAN 1615	114	.00	.00	.00	0.
2 JAN 0015	50	.04	.03	.00	0.	*	2 JAN 1630	115	.00	.00	.00	0.
2 JAN 0030	51	.04	.03	.00	0.	*	2 JAN 1645	116	.00	.00	.00	0.
2 JAN 0045	52	.02	.02	.00	0.	*	2 JAN 1700	117	.00	.00	.00	0.
2 JAN 0100	53	.02	.02	.00	0.	*	2 JAN 1715	118	.00	.00	.00	0.
2 JAN 0115	54	.01	.01	.00	0.	*	2 JAN 1730	119	.00	.00	.00	0.
2 JAN 0130	55	.01	.01	.00	0.	*	2 JAN 1745	120	.00	.00	.00	0.
2 JAN 0145	56	.01	.01	.00	0.	*	2 JAN 1800	121	.00	.00	.00	0.
2 JAN 0200	57	.01	.01	.00	0.	*	2 JAN 1815	122	.00	.00	.00	0.
2 JAN 0215	58	.01	.01	.00	0.	*	2 JAN 1830	123	.00	.00	.00	0.
2 JAN 0230	59	.01	.01	.00	0.	*	2 JAN 1845	124	.00	.00	.00	0.
2 JAN 0245	60	.01	.01	.00	0.	*	2 JAN 1900	125	.00	.00	.00	0.
2 JAN 0300	61	.01	.01	.00	0.	*	2 JAN 1915	126	.00	.00	.00	0.
2 JAN 0315	62	.01	.01	.00	0.	*	2 JAN 1930	127	.00	.00	.00	0.
2 JAN 0330	63	.01	.01	.00	0.	*	2 JAN 1945	128	.00	.00	.00	0.
2 JAN 0345	64	.01	.01	.00	0.	*	2 JAN 2000	129	.00	.00	.00	0.
2 JAN 0400	65	.01	.01	.00	0.	*						

TOTAL RAINFALL = 1.00, TOTAL LOSS = .90, TOTAL EXCESS = .10

PEAK FLOW (CFS)	TIME (HR)	MAXIMUM AVERAGE FLOW			
		6-HR	24-HR	72-HR	32.00-HR
0.	12.00	0.	0.	0.	0.
	(INCHES)	.070	.100	.101	.101
	(AC-FT)	0.	0.	0.	0.

CUMULATIVE AREA = .01 SQ MI

WARNING *** TIME INTERVAL IS GREATER THAN .29*LAG

HYDROGRAPH AT STATION BSND
PLAN 1, RATIO = 7.80

DA	MON	HRMN	ORD	RAIN	LOSS	EXCESS	COMP Q		DA	MON	HRMN	ORD	RAIN	LOSS	EXCESS	COMP Q
1	JAN	1200	1	.00	.00	.00	0.	*	2	JAN	0415	66	.04	.01	.03	1.
1	JAN	1215	2	.02	.02	.00	0.	*	2	JAN	0430	67	.03	.01	.03	1.

1 JAN 1230	3	.02	.02	.00	0.	*	2 JAN 0445	68	.04	.01	.03	1.
1 JAN 1245	4	.02	.01	.00	0.	*	2 JAN 0500	69	.03	.01	.03	1.
1 JAN 1300	5	.02	.02	.00	0.	*	2 JAN 0515	70	.04	.01	.03	1.
1 JAN 1315	6	.02	.02	.00	0.	*	2 JAN 0530	71	.03	.01	.03	1.
1 JAN 1330	7	.02	.02	.00	0.	*	2 JAN 0545	72	.04	.01	.03	1.
1 JAN 1345	8	.02	.01	.00	0.	*	2 JAN 0600	73	.03	.01	.03	1.
1 JAN 1400	9	.02	.02	.00	0.	*	2 JAN 0615	74	.04	.01	.03	1.
1 JAN 1415	10	.02	.02	.00	0.	*	2 JAN 0630	75	.03	.01	.03	1.
1 JAN 1430	11	.03	.03	.00	0.	*	2 JAN 0645	76	.03	.01	.03	0.
1 JAN 1445	12	.02	.02	.00	0.	*	2 JAN 0700	77	.04	.01	.03	1.
1 JAN 1500	13	.02	.02	.00	0.	*	2 JAN 0715	78	.03	.01	.03	1.
1 JAN 1515	14	.02	.02	.00	0.	*	2 JAN 0730	79	.04	.01	.03	1.
1 JAN 1530	15	.03	.03	.00	0.	*	2 JAN 0745	80	.03	.01	.03	1.
1 JAN 1545	16	.02	.02	.00	0.	*	2 JAN 0800	81	.04	.01	.03	1.
1 JAN 1600	17	.02	.02	.00	0.	*	2 JAN 0815	82	.02	.00	.02	0.
1 JAN 1615	18	.03	.03	.00	0.	*	2 JAN 0830	83	.02	.00	.02	0.
1 JAN 1630	19	.03	.03	.00	0.	*	2 JAN 0845	84	.02	.00	.02	0.
1 JAN 1645	20	.03	.03	.00	0.	*	2 JAN 0900	85	.02	.00	.02	0.
1 JAN 1700	21	.03	.03	.00	0.	*	2 JAN 0915	86	.02	.00	.02	0.
1 JAN 1715	22	.03	.03	.00	0.	*	2 JAN 0930	87	.02	.00	.02	0.
1 JAN 1730	23	.03	.03	.00	0.	*	2 JAN 0945	88	.02	.00	.02	0.
1 JAN 1745	24	.03	.03	.00	0.	*	2 JAN 1000	89	.02	.00	.02	0.
1 JAN 1800	25	.03	.03	.00	0.	*	2 JAN 1015	90	.02	.00	.02	0.
1 JAN 1815	26	.04	.04	.00	0.	*	2 JAN 1030	91	.02	.00	.02	0.
1 JAN 1830	27	.04	.04	.00	0.	*	2 JAN 1045	92	.02	.00	.02	0.
1 JAN 1845	28	.04	.04	.00	0.	*	2 JAN 1100	93	.02	.00	.02	0.
1 JAN 1900	29	.04	.04	.00	0.	*	2 JAN 1115	94	.02	.00	.02	0.
1 JAN 1915	30	.04	.04	.00	0.	*	2 JAN 1130	95	.02	.00	.02	0.
1 JAN 1930	31	.04	.04	.00	0.	*	2 JAN 1145	96	.02	.00	.02	0.
1 JAN 1945	32	.04	.04	.00	0.	*	2 JAN 1200	97	.02	.00	.02	0.
1 JAN 2000	33	.04	.04	.00	0.	*	2 JAN 1215	98	.00	.00	.00	0.
1 JAN 2015	34	.05	.05	.01	0.	*	2 JAN 1230	99	.00	.00	.00	0.
1 JAN 2030	35	.05	.05	.01	0.	*	2 JAN 1245	100	.00	.00	.00	0.
1 JAN 2045	36	.05	.04	.01	0.	*	2 JAN 1300	101	.00	.00	.00	0.
1 JAN 2100	37	.05	.05	.01	0.	*	2 JAN 1315	102	.00	.00	.00	0.
1 JAN 2115	38	.06	.05	.01	0.	*	2 JAN 1330	103	.00	.00	.00	0.
1 JAN 2130	39	.06	.05	.01	0.	*	2 JAN 1345	104	.00	.00	.00	0.
1 JAN 2145	40	.07	.05	.02	0.	*	2 JAN 1400	105	.00	.00	.00	0.
1 JAN 2200	41	.07	.05	.02	0.	*	2 JAN 1415	106	.00	.00	.00	0.
1 JAN 2215	42	.09	.07	.03	0.	*	2 JAN 1430	107	.00	.00	.00	0.
1 JAN 2230	43	.09	.06	.03	0.	*	2 JAN 1445	108	.00	.00	.00	0.
1 JAN 2245	44	.12	.08	.04	1.	*	2 JAN 1500	109	.00	.00	.00	0.
1 JAN 2300	45	.12	.08	.04	1.	*	2 JAN 1515	110	.00	.00	.00	0.
1 JAN 2315	46	.19	.12	.07	1.	*	2 JAN 1530	111	.00	.00	.00	0.
1 JAN 2330	47	.19	.11	.08	1.	*	2 JAN 1545	112	.00	.00	.00	0.
1 JAN 2345	48	.81	.40	.41	4.	*	2 JAN 1600	113	.00	.00	.00	0.
2 JAN 0000	49	2.15	.71	1.44	16.	*	2 JAN 1615	114	.00	.00	.00	0.
2 JAN 0015	50	.28	.07	.21	12.	*	2 JAN 1630	115	.00	.00	.00	0.
2 JAN 0030	51	.28	.06	.22	6.	*	2 JAN 1645	116	.00	.00	.00	0.
2 JAN 0045	52	.15	.03	.12	4.	*	2 JAN 1700	117	.00	.00	.00	0.
2 JAN 0100	53	.14	.03	.11	2.	*	2 JAN 1715	118	.00	.00	.00	0.
2 JAN 0115	54	.11	.02	.09	2.	*	2 JAN 1730	119	.00	.00	.00	0.
2 JAN 0130	55	.10	.02	.08	2.	*	2 JAN 1745	120	.00	.00	.00	0.
2 JAN 0145	56	.09	.02	.07	1.	*	2 JAN 1800	121	.00	.00	.00	0.
2 JAN 0200	57	.08	.02	.06	1.	*	2 JAN 1815	122	.00	.00	.00	0.
2 JAN 0215	58	.06	.01	.05	1.	*	2 JAN 1830	123	.00	.00	.00	0.
2 JAN 0230	59	.05	.01	.04	1.	*	2 JAN 1845	124	.00	.00	.00	0.
2 JAN 0245	60	.06	.01	.05	1.	*	2 JAN 1900	125	.00	.00	.00	0.
2 JAN 0300	61	.05	.01	.04	1.	*	2 JAN 1915	126	.00	.00	.00	0.
2 JAN 0315	62	.06	.01	.05	1.	*	2 JAN 1930	127	.00	.00	.00	0.

2 JAN 0330	63	.05	.01	.04	1.	*	2 JAN 1945	128	.00	.00	.00	0.
2 JAN 0345	64	.06	.01	.05	1.	*	2 JAN 2000	129	.00	.00	.00	0.
2 JAN 0400	65	.05	.01	.04	1.	*						

TOTAL RAINFALL = 7.80, TOTAL LOSS = 3.36, TOTAL EXCESS = 4.44

PEAK FLOW (CFS)	TIME (HR)	MAXIMUM AVERAGE FLOW			
		6-HR	24-HR	72-HR	32.00-HR
16.	12.00	3.	1.	1.	1.
		(INCHES) 3.481	4.437	4.441	4.441
		(AC-FT) 1.	2.	2.	2.

CUMULATIVE AREA = .01 SQ MI

*** ** ** ** **

* *
53 KK * B&D *
* *

HYDROGRAPH COMBINATION
ICOMP 2 NUMBER OF HYDROGRAPHS TO COMBINE

HYDROGRAPH AT STATION B&D
SUM OF 2 HYDROGRAPHS
PLAN 1, RATIO = 7.80

DA	MON	HRMN	ORD	FLOW	*	DA	MON	HRMN	ORD	FLOW	*	DA	MON	HRMN	ORD	FLOW	*	DA	MON	HRMN	ORD	FLOW	*
1	JAN	1200	1	0.	*	1	JAN	2015	34	0.	*	2	JAN	0430	67	1.	*	2	JAN	1245	100	0.	*
1	JAN	1215	2	0.	*	1	JAN	2030	35	0.	*	2	JAN	0445	68	1.	*	2	JAN	1300	101	0.	*
1	JAN	1230	3	0.	*	1	JAN	2045	36	0.	*	2	JAN	0500	69	1.	*	2	JAN	1315	102	0.	*
1	JAN	1245	4	0.	*	1	JAN	2100	37	0.	*	2	JAN	0515	70	1.	*	2	JAN	1330	103	0.	*
1	JAN	1300	5	0.	*	1	JAN	2115	38	0.	*	2	JAN	0530	71	1.	*	2	JAN	1345	104	0.	*
1	JAN	1315	6	0.	*	1	JAN	2130	39	0.	*	2	JAN	0545	72	1.	*	2	JAN	1400	105	0.	*
1	JAN	1330	7	0.	*	1	JAN	2145	40	0.	*	2	JAN	0600	73	1.	*	2	JAN	1415	106	0.	*
1	JAN	1345	8	0.	*	1	JAN	2200	41	0.	*	2	JAN	0615	74	1.	*	2	JAN	1430	107	0.	*
1	JAN	1400	9	0.	*	1	JAN	2215	42	0.	*	2	JAN	0630	75	1.	*	2	JAN	1445	108	0.	*
1	JAN	1415	10	0.	*	1	JAN	2230	43	0.	*	2	JAN	0645	76	1.	*	2	JAN	1500	109	0.	*
1	JAN	1430	11	0.	*	1	JAN	2245	44	1.	*	2	JAN	0700	77	1.	*	2	JAN	1515	110	0.	*
1	JAN	1445	12	0.	*	1	JAN	2300	45	1.	*	2	JAN	0715	78	1.	*	2	JAN	1530	111	0.	*
1	JAN	1500	13	0.	*	1	JAN	2315	46	1.	*	2	JAN	0730	79	1.	*	2	JAN	1545	112	0.	*
1	JAN	1515	14	0.	*	1	JAN	2330	47	1.	*	2	JAN	0745	80	1.	*	2	JAN	1600	113	0.	*
1	JAN	1530	15	0.	*	1	JAN	2345	48	5.	*	2	JAN	0800	81	1.	*	2	JAN	1615	114	0.	*

1 JAN 1545	16	0.	*	2 JAN 0000	49	19.	*	2 JAN 0815	82	1.	*	2 JAN 1630	115	0.
1 JAN 1600	17	0.	*	2 JAN 0015	50	13.	*	2 JAN 0830	83	0.	*	2 JAN 1645	116	0.
1 JAN 1615	18	0.	*	2 JAN 0030	51	7.	*	2 JAN 0845	84	0.	*	2 JAN 1700	117	0.
1 JAN 1630	19	0.	*	2 JAN 0045	52	4.	*	2 JAN 0900	85	0.	*	2 JAN 1715	118	0.
1 JAN 1645	20	0.	*	2 JAN 0100	53	3.	*	2 JAN 0915	86	0.	*	2 JAN 1730	119	0.
1 JAN 1700	21	0.	*	2 JAN 0115	54	2.	*	2 JAN 0930	87	0.	*	2 JAN 1745	120	0.
1 JAN 1715	22	0.	*	2 JAN 0130	55	2.	*	2 JAN 0945	88	0.	*	2 JAN 1800	121	0.
1 JAN 1730	23	0.	*	2 JAN 0145	56	2.	*	2 JAN 1000	89	0.	*	2 JAN 1815	122	0.
1 JAN 1745	24	0.	*	2 JAN 0200	57	1.	*	2 JAN 1015	90	0.	*	2 JAN 1830	123	0.
1 JAN 1800	25	0.	*	2 JAN 0215	58	1.	*	2 JAN 1030	91	0.	*	2 JAN 1845	124	0.
1 JAN 1815	26	0.	*	2 JAN 0230	59	1.	*	2 JAN 1045	92	0.	*	2 JAN 1900	125	0.
1 JAN 1830	27	0.	*	2 JAN 0245	60	1.	*	2 JAN 1100	93	0.	*	2 JAN 1915	126	0.
1 JAN 1845	28	0.	*	2 JAN 0300	61	1.	*	2 JAN 1115	94	0.	*	2 JAN 1930	127	0.
1 JAN 1900	29	0.	*	2 JAN 0315	62	1.	*	2 JAN 1130	95	0.	*	2 JAN 1945	128	0.
1 JAN 1915	30	0.	*	2 JAN 0330	63	1.	*	2 JAN 1145	96	0.	*	2 JAN 2000	129	0.
1 JAN 1930	31	0.	*	2 JAN 0345	64	1.	*	2 JAN 1200	97	0.	*			
1 JAN 1945	32	0.	*	2 JAN 0400	65	1.	*	2 JAN 1215	98	0.	*			
1 JAN 2000	33	0.	*	2 JAN 0415	66	1.	*	2 JAN 1230	99	0.	*			
			*				*				*			

PEAK FLOW + (CFS)	TIME (HR)	MAXIMUM AVERAGE FLOW			
		6-HR	24-HR	72-HR	32.00-HR
+ 19.	12.00	3.	1.	1.	1.
		(INCHES) 3.481	4.437	4.441	4.441
		(AC-FT) 1.	2.	2.	2.

CUMULATIVE AREA = .01 SQ MI

*** **

* *
55 KK * POND2 *
* *

HYDROGRAPH ROUTING DATA

56 RS	STORAGE ROUTING										
	NSTPS	1	NUMBER OF SUBREACHES								
	ITYP	ELEV	TYPE OF INITIAL CONDITION								
	RSVRIC	1346.00	INITIAL CONDITION								
	X	.00	WORKING R AND D COEFFICIENT								
57 SA	AREA	.6	.7	.8	.8						
58 SE	ELEVATION	1353.00	1354.00	1355.00	1356.00						
SQ	DISCHARGE	0.	2.	4.	6.	8.	10.	11.	13.	15.	17.
		19.									
61 SE	ELEVATION	1353.00	1353.66	1354.02	1354.30	1354.58	1354.90	1355.30	1355.78	1356.34	1356.97
		1357.70									

COMPUTED STORAGE-ELEVATION DATA

STORAGE	.00	.62	1.33	2.13
ELEVATION	1353.00	1354.00	1355.00	1356.00

COMPUTED STORAGE-OUTFLOW-ELEVATION DATA

STORAGE	.00	.40	.62	.64	.83	1.03	1.26	1.33	1.56	1.95
OUTFLOW	.00	1.90	3.69	3.80	5.70	7.60	9.50	9.97	11.40	13.30
ELEVATION	1353.00	1353.66	1354.00	1354.02	1354.30	1354.58	1354.90	1355.00	1355.30	1355.78

STORAGE	2.13	2.42	2.99	3.69
OUTFLOW	14.05	15.20	17.10	19.00
ELEVATION	1356.00	1356.34	1356.97	1357.70

HYDROGRAPH AT STATION POND2

PLAN 1, RATIO = 7.80

HYDROGRAPH AT STATION POND2																						
PLAN 1, RATIO = 7.80																						

DA	MON	HRMN	ORD	OUTFLOW	STORAGE	STAGE	DA	MON	HRMN	ORD	OUTFLOW	STORAGE	STAGE	DA	MON	HRMN	ORD	OUTFLOW	STORAGE	STAGE		

1	JAN	1200	1	0.	.0	1353.0	*	1	JAN	2245	44	0.	.0	1353.1	*	2	JAN	0930	87	1.	.1	1353.2
1	JAN	1215	2	0.	.0	1353.0	*	1	JAN	2300	45	0.	.1	1353.1	*	2	JAN	0945	88	1.	.1	1353.2
1	JAN	1230	3	0.	.0	1353.0	*	1	JAN	2315	46	0.	.1	1353.1	*	2	JAN	1000	89	1.	.1	1353.2
1	JAN	1245	4	0.	.0	1353.0	*	1	JAN	2330	47	0.	.1	1353.2	*	2	JAN	1015	90	1.	.1	1353.2
1	JAN	1300	5	0.	.0	1353.0	*	1	JAN	2345	48	1.	.1	1353.2	*	2	JAN	1030	91	1.	.1	1353.2
1	JAN	1315	6	0.	.0	1353.0	*	2	JAN	0000	49	2.	.4	1353.6	*	2	JAN	1045	92	1.	.1	1353.2
1	JAN	1330	7	0.	.0	1353.0	*	2	JAN	0015	50	4.	.7	1354.0	*	2	JAN	1100	93	1.	.1	1353.2
1	JAN	1345	8	0.	.0	1353.0	*	2	JAN	0030	51	5.	.8	1354.2	*	2	JAN	1115	94	1.	.1	1353.2
1	JAN	1400	9	0.	.0	1353.0	*	2	JAN	0045	52	5.	.8	1354.2	*	2	JAN	1130	95	1.	.1	1353.2
1	JAN	1415	10	0.	.0	1353.0	*	2	JAN	0100	53	5.	.7	1354.2	*	2	JAN	1145	96	1.	.1	1353.2
1	JAN	1430	11	0.	.0	1353.0	*	2	JAN	0115	54	4.	.7	1354.1	*	2	JAN	1200	97	1.	.1	1353.2
1	JAN	1445	12	0.	.0	1353.0	*	2	JAN	0130	55	4.	.7	1354.0	*	2	JAN	1215	98	0.	.1	1353.2
1	JAN	1500	13	0.	.0	1353.0	*	2	JAN	0145	56	4.	.6	1354.0	*	2	JAN	1230	99	0.	.1	1353.2
1	JAN	1515	14	0.	.0	1353.0	*	2	JAN	0200	57	3.	.6	1353.9	*	2	JAN	1245	100	0.	.1	1353.1
1	JAN	1530	15	0.	.0	1353.0	*	2	JAN	0215	58	3.	.5	1353.9	*	2	JAN	1300	101	0.	.1	1353.1
1	JAN	1545	16	0.	.0	1353.0	*	2	JAN	0230	59	3.	.5	1353.8	*	2	JAN	1315	102	0.	.1	1353.1
1	JAN	1600	17	0.	.0	1353.0	*	2	JAN	0245	60	2.	.5	1353.8	*	2	JAN	1330	103	0.	.1	1353.1
1	JAN	1615	18	0.	.0	1353.0	*	2	JAN	0300	61	2.	.4	1353.7	*	2	JAN	1345	104	0.	.1	1353.1
1	JAN	1630	19	0.	.0	1353.0	*	2	JAN	0315	62	2.	.4	1353.7	*	2	JAN	1400	105	0.	.1	1353.1
1	JAN	1645	20	0.	.0	1353.0	*	2	JAN	0330	63	2.	.4	1353.6	*	2	JAN	1415	106	0.	.0	1353.1
1	JAN	1700	21	0.	.0	1353.0	*	2	JAN	0345	64	2.	.4	1353.6	*	2	JAN	1430	107	0.	.0	1353.1
1	JAN	1715	22	0.	.0	1353.0	*	2	JAN	0400	65	2.	.4	1353.6	*	2	JAN	1445	108	0.	.0	1353.1
1	JAN	1730	23	0.	.0	1353.0	*	2	JAN	0415	66	2.	.3	1353.6	*	2	JAN	1500	109	0.	.0	1353.1
1	JAN	1745	24	0.	.0	1353.0	*	2	JAN	0430	67	2.	.3	1353.5	*	2	JAN	1515	110	0.	.0	1353.1
1	JAN	1800	25	0.	.0	1353.0	*	2	JAN	0445	68	1.	.3	1353.5	*	2	JAN	1530	111	0.	.0	1353.0
1	JAN	1815	26	0.	.0	1353.0	*	2	JAN	0500	69	1.	.3	1353.5	*	2	JAN	1545	112	0.	.0	1353.0
1	JAN	1830	27	0.	.0	1353.0	*	2	JAN	0515	70	1.	.3	1353.5	*	2	JAN	1600	113	0.	.0	1353.0
1	JAN	1845	28	0.	.0	1353.0	*	2	JAN	0530	71	1.	.3	1353.4	*	2	JAN	1615	114	0.	.0	1353.0
1	JAN	1900	29	0.	.0	1353.0	*	2	JAN	0545	72	1.	.3	1353.4	*	2	JAN	1630	115	0.	.0	1353.0
1	JAN	1915	30	0.	.0	1353.0	*	2	JAN	0600	73	1.	.2	1353.4	*	2	JAN	1645	116	0.	.0	1353.0
1	JAN	1930	31	0.	.0	1353.0	*	2	JAN	0615	74	1.	.2	1353.4	*	2	JAN	1700	117	0.	.0	1353.0
1	JAN	1945	32	0.	.0	1353.0	*	2	JAN	0630	75	1.	.2	1353.4	*	2	JAN	1715	118	0.	.0	1353.0
1	JAN	2000	33	0.	.0	1353.0	*	2	JAN	0645	76	1.	.2	1353.3	*	2	JAN	1730	119	0.	.0	1353.0

1 JAN 2015	34	0.	.0	1353.0 *	2 JAN 0700	77	1.	.2	1353.3 *	2 JAN 1745	120	0.	.0	1353.0
1 JAN 2030	35	0.	.0	1353.0 *	2 JAN 0715	78	1.	.2	1353.3 *	2 JAN 1800	121	0.	.0	1353.0
1 JAN 2045	36	0.	.0	1353.0 *	2 JAN 0730	79	1.	.2	1353.3 *	2 JAN 1815	122	0.	.0	1353.0
1 JAN 2100	37	0.	.0	1353.0 *	2 JAN 0745	80	1.	.2	1353.3 *	2 JAN 1830	123	0.	.0	1353.0
1 JAN 2115	38	0.	.0	1353.0 *	2 JAN 0800	81	1.	.2	1353.3 *	2 JAN 1845	124	0.	.0	1353.0
1 JAN 2130	39	0.	.0	1353.0 *	2 JAN 0815	82	1.	.2	1353.3 *	2 JAN 1900	125	0.	.0	1353.0
1 JAN 2145	40	0.	.0	1353.0 *	2 JAN 0830	83	1.	.2	1353.3 *	2 JAN 1915	126	0.	.0	1353.0
1 JAN 2200	41	0.	.0	1353.0 *	2 JAN 0845	84	1.	.2	1353.3 *	2 JAN 1930	127	0.	.0	1353.0
1 JAN 2215	42	0.	.0	1353.1 *	2 JAN 0900	85	1.	.2	1353.3 *	2 JAN 1945	128	0.	.0	1353.0
1 JAN 2230	43	0.	.0	1353.1 *	2 JAN 0915	86	1.	.1	1353.2 *	2 JAN 2000	129	0.	.0	1353.0

PEAK FLOW + (CFS)	TIME (HR)	MAXIMUM AVERAGE FLOW				
		6-HR	24-HR	72-HR	32.00-HR	
5.	12.75	3.	1.	1.	1.	
		(INCHES)	3.049	4.381	4.429	4.429
		(AC-FT)	1.	2.	2.	2.

PEAK STORAGE + (AC-FT)	TIME (HR)	MAXIMUM AVERAGE STORAGE			
		6-HR	24-HR	72-HR	32.00-HR
1.	12.75	0.	0.	0.	0.

PEAK STAGE + (FEET)	TIME (HR)	MAXIMUM AVERAGE STAGE			
		6-HR	24-HR	72-HR	32.00-HR
4.22	12.75	1353.76	1353.29	1353.22	1353.22

CUMULATIVE AREA = .01 SQ MI

*** **

* *
63 KK * BSNC *
* *

5 IN TIME DATA FOR INPUT TIME SERIES
JXMIN 15 TIME INTERVAL IN MINUTES
JXDATE 1JAN 3 STARTING DATE
JXTIME 1200 STARTING TIME

SUBBASIN RUNOFF DATA

64 BA SUBBASIN CHARACTERISTICS
TAREA .01 SUBBASIN AREA

PRECIPITATION DATA

65 PB STORM 1.00 BASIN TOTAL PRECIPITATION

66 PI INCREMENTAL PRECIPITATION PATTERN

.00	.00	.00	.00	.00	.00	.00	.00	.00	.00
.00	.00	.00	.00	.00	.00	.00	.00	.00	.00
.00	.00	.00	.00	.01	.01	.00	.01	.00	.01
.01	.00	.01	.01	.01	.01	.01	.01	.01	.01
.01	.01	.02	.02	.02	.02	.10	.28	.04	.04
.02	.02	.01	.01	.01	.01	.01	.01	.01	.01
.01	.01	.01	.01	.00	.00	.00	.00	.00	.00
.00	.00	.00	.00	.00	.00	.00	.00	.00	.00
.00	.00	.00	.00	.00	.00	.00	.00	.00	.00
.00	.00	.00	.00	.00	.00	.00	.00	.00	.00

76 LS SCS LOSS RATE
 STRTL .94 INITIAL ABSTRACTION
 CRVNBR 68.00 CURVE NUMBER
 RTIMP 10.00 PERCENT IMPERVIOUS AREA

77 UD SCS DIMENSIONLESS UNITGRAPH
 TLAG .22 LAG

WARNING *** TIME INTERVAL IS GREATER THAN .29*LAG

UNIT HYDROGRAPH
 6 END-OF-PERIOD ORDINATES

9. 8. 2. 1. 0. 0.

HYDROGRAPH AT STATION BSNC

DA	MON	HRMN	ORD	RAIN	LOSS	EXCESS	COMP Q	*	DA	MON	HRMN	ORD	RAIN	LOSS	EXCESS	COMP Q
1	JAN	1200	1	.00	.00	.00	0.	*	2	JAN	0415	66	.00	.00	.00	0.
1	JAN	1215	2	.00	.00	.00	0.	*	2	JAN	0430	67	.00	.00	.00	0.
1	JAN	1230	3	.00	.00	.00	0.	*	2	JAN	0445	68	.00	.00	.00	0.
1	JAN	1245	4	.00	.00	.00	0.	*	2	JAN	0500	69	.00	.00	.00	0.
1	JAN	1300	5	.00	.00	.00	0.	*	2	JAN	0515	70	.00	.00	.00	0.
1	JAN	1315	6	.00	.00	.00	0.	*	2	JAN	0530	71	.00	.00	.00	0.
1	JAN	1330	7	.00	.00	.00	0.	*	2	JAN	0545	72	.00	.00	.00	0.
1	JAN	1345	8	.00	.00	.00	0.	*	2	JAN	0600	73	.00	.00	.00	0.
1	JAN	1400	9	.00	.00	.00	0.	*	2	JAN	0615	74	.00	.00	.00	0.
1	JAN	1415	10	.00	.00	.00	0.	*	2	JAN	0630	75	.00	.00	.00	0.
1	JAN	1430	11	.00	.00	.00	0.	*	2	JAN	0645	76	.00	.00	.00	0.
1	JAN	1445	12	.00	.00	.00	0.	*	2	JAN	0700	77	.00	.00	.00	0.
1	JAN	1500	13	.00	.00	.00	0.	*	2	JAN	0715	78	.00	.00	.00	0.
1	JAN	1515	14	.00	.00	.00	0.	*	2	JAN	0730	79	.00	.00	.00	0.
1	JAN	1530	15	.00	.00	.00	0.	*	2	JAN	0745	80	.00	.00	.00	0.
1	JAN	1545	16	.00	.00	.00	0.	*	2	JAN	0800	81	.00	.00	.00	0.
1	JAN	1600	17	.00	.00	.00	0.	*	2	JAN	0815	82	.00	.00	.00	0.
1	JAN	1615	18	.00	.00	.00	0.	*	2	JAN	0830	83	.00	.00	.00	0.
1	JAN	1630	19	.00	.00	.00	0.	*	2	JAN	0845	84	.00	.00	.00	0.
1	JAN	1645	20	.00	.00	.00	0.	*	2	JAN	0900	85	.00	.00	.00	0.
1	JAN	1700	21	.00	.00	.00	0.	*	2	JAN	0915	86	.00	.00	.00	0.
1	JAN	1715	22	.00	.00	.00	0.	*	2	JAN	0930	87	.00	.00	.00	0.
1	JAN	1730	23	.00	.00	.00	0.	*	2	JAN	0945	88	.00	.00	.00	0.
1	JAN	1745	24	.00	.00	.00	0.	*	2	JAN	1000	89	.00	.00	.00	0.
1	JAN	1800	25	.00	.00	.00	0.	*	2	JAN	1015	90	.00	.00	.00	0.

1 JAN 1815	26	.01	.00	.00	0.	*	2 JAN 1030	91	.00	.00	.00	0.
1 JAN 1830	27	.01	.00	.00	0.	*	2 JAN 1045	92	.00	.00	.00	0.
1 JAN 1845	28	.00	.00	.00	0.	*	2 JAN 1100	93	.00	.00	.00	0.
1 JAN 1900	29	.01	.00	.00	0.	*	2 JAN 1115	94	.00	.00	.00	0.
1 JAN 1915	30	.00	.00	.00	0.	*	2 JAN 1130	95	.00	.00	.00	0.
1 JAN 1930	31	.01	.00	.00	0.	*	2 JAN 1145	96	.00	.00	.00	0.
1 JAN 1945	32	.01	.00	.00	0.	*	2 JAN 1200	97	.00	.00	.00	0.
1 JAN 2000	33	.00	.00	.00	0.	*	2 JAN 1215	98	.00	.00	.00	0.
1 JAN 2015	34	.01	.01	.00	0.	*	2 JAN 1230	99	.00	.00	.00	0.
1 JAN 2030	35	.01	.01	.00	0.	*	2 JAN 1245	100	.00	.00	.00	0.
1 JAN 2045	36	.01	.01	.00	0.	*	2 JAN 1300	101	.00	.00	.00	0.
1 JAN 2100	37	.01	.01	.00	0.	*	2 JAN 1315	102	.00	.00	.00	0.
1 JAN 2115	38	.01	.01	.00	0.	*	2 JAN 1330	103	.00	.00	.00	0.
1 JAN 2130	39	.01	.01	.00	0.	*	2 JAN 1345	104	.00	.00	.00	0.
1 JAN 2145	40	.01	.01	.00	0.	*	2 JAN 1400	105	.00	.00	.00	0.
1 JAN 2200	41	.01	.01	.00	0.	*	2 JAN 1415	106	.00	.00	.00	0.
1 JAN 2215	42	.01	.01	.00	0.	*	2 JAN 1430	107	.00	.00	.00	0.
1 JAN 2230	43	.01	.01	.00	0.	*	2 JAN 1445	108	.00	.00	.00	0.
1 JAN 2245	44	.02	.01	.00	0.	*	2 JAN 1500	109	.00	.00	.00	0.
1 JAN 2300	45	.02	.01	.00	0.	*	2 JAN 1515	110	.00	.00	.00	0.
1 JAN 2315	46	.02	.02	.00	0.	*	2 JAN 1530	111	.00	.00	.00	0.
1 JAN 2330	47	.02	.02	.00	0.	*	2 JAN 1545	112	.00	.00	.00	0.
1 JAN 2345	48	.10	.09	.01	0.	*	2 JAN 1600	113	.00	.00	.00	0.
2 JAN 0000	49	.28	.25	.03	0.	*	2 JAN 1615	114	.00	.00	.00	0.
2 JAN 0015	50	.04	.03	.00	0.	*	2 JAN 1630	115	.00	.00	.00	0.
2 JAN 0030	51	.04	.03	.00	0.	*	2 JAN 1645	116	.00	.00	.00	0.
2 JAN 0045	52	.02	.02	.00	0.	*	2 JAN 1700	117	.00	.00	.00	0.
2 JAN 0100	53	.02	.02	.00	0.	*	2 JAN 1715	118	.00	.00	.00	0.
2 JAN 0115	54	.01	.01	.00	0.	*	2 JAN 1730	119	.00	.00	.00	0.
2 JAN 0130	55	.01	.01	.00	0.	*	2 JAN 1745	120	.00	.00	.00	0.
2 JAN 0145	56	.01	.01	.00	0.	*	2 JAN 1800	121	.00	.00	.00	0.
2 JAN 0200	57	.01	.01	.00	0.	*	2 JAN 1815	122	.00	.00	.00	0.
2 JAN 0215	58	.01	.01	.00	0.	*	2 JAN 1830	123	.00	.00	.00	0.
2 JAN 0230	59	.01	.01	.00	0.	*	2 JAN 1845	124	.00	.00	.00	0.
2 JAN 0245	60	.01	.01	.00	0.	*	2 JAN 1900	125	.00	.00	.00	0.
2 JAN 0300	61	.01	.01	.00	0.	*	2 JAN 1915	126	.00	.00	.00	0.
2 JAN 0315	62	.01	.01	.00	0.	*	2 JAN 1930	127	.00	.00	.00	0.
2 JAN 0330	63	.01	.01	.00	0.	*	2 JAN 1945	128	.00	.00	.00	0.
2 JAN 0345	64	.01	.01	.00	0.	*	2 JAN 2000	129	.00	.00	.00	0.
2 JAN 0400	65	.01	.01	.00	0.	*						

TOTAL RAINFALL = 1.00, TOTAL LOSS = .90, TOTAL EXCESS = .10

PEAK FLOW (CFS)	TIME (HR)	MAXIMUM AVERAGE FLOW				
		6-HR	24-HR	72-HR	32.00-HR	
0.	12.00	0.	0.	0.	0.	
		(INCHES)	.070	.100	.101	.101
		(AC-FT)	0.	0.	0.	0.

CUMULATIVE AREA = .01 SQ MI

WARNING *** TIME INTERVAL IS GREATER THAN .29*LAG

HYDROGRAPH AT STATION BSNC

PLAN 1, RATIO = 7.80

DA	MON	HRMN	ORD	RAIN	LOSS	EXCESS	COMP Q	*	DA	MON	HRMN	ORD	RAIN	LOSS	EXCESS	COMP Q
1	JAN	1200	1	.00	.00	.00	0.	*	2	JAN	0415	66	.04	.01	.03	1.
1	JAN	1215	2	.02	.02	.00	0.	*	2	JAN	0430	67	.03	.01	.03	1.
1	JAN	1230	3	.02	.02	.00	0.	*	2	JAN	0445	68	.04	.01	.03	1.
1	JAN	1245	4	.02	.01	.00	0.	*	2	JAN	0500	69	.03	.01	.03	1.
1	JAN	1300	5	.02	.02	.00	0.	*	2	JAN	0515	70	.04	.01	.03	1.
1	JAN	1315	6	.02	.02	.00	0.	*	2	JAN	0530	71	.03	.01	.03	1.
1	JAN	1330	7	.02	.02	.00	0.	*	2	JAN	0545	72	.04	.01	.03	1.
1	JAN	1345	8	.02	.01	.00	0.	*	2	JAN	0600	73	.03	.01	.03	1.
1	JAN	1400	9	.02	.02	.00	0.	*	2	JAN	0615	74	.04	.01	.03	1.
1	JAN	1415	10	.02	.02	.00	0.	*	2	JAN	0630	75	.03	.01	.03	1.
1	JAN	1430	11	.03	.03	.00	0.	*	2	JAN	0645	76	.03	.01	.03	1.
1	JAN	1445	12	.02	.02	.00	0.	*	2	JAN	0700	77	.04	.01	.03	1.
1	JAN	1500	13	.02	.02	.00	0.	*	2	JAN	0715	78	.03	.01	.03	1.
1	JAN	1515	14	.02	.02	.00	0.	*	2	JAN	0730	79	.04	.01	.03	1.
1	JAN	1530	15	.03	.03	.00	0.	*	2	JAN	0745	80	.03	.01	.03	1.
1	JAN	1545	16	.02	.02	.00	0.	*	2	JAN	0800	81	.04	.01	.03	1.
1	JAN	1600	17	.02	.02	.00	0.	*	2	JAN	0815	82	.02	.00	.02	1.
1	JAN	1615	18	.03	.03	.00	0.	*	2	JAN	0830	83	.02	.00	.02	0.
1	JAN	1630	19	.03	.03	.00	0.	*	2	JAN	0845	84	.02	.00	.02	0.
1	JAN	1645	20	.03	.03	.00	0.	*	2	JAN	0900	85	.02	.00	.02	0.
1	JAN	1700	21	.03	.03	.00	0.	*	2	JAN	0915	86	.02	.00	.02	0.
1	JAN	1715	22	.03	.03	.00	0.	*	2	JAN	0930	87	.02	.00	.02	0.
1	JAN	1730	23	.03	.03	.00	0.	*	2	JAN	0945	88	.02	.00	.02	0.
1	JAN	1745	24	.03	.03	.00	0.	*	2	JAN	1000	89	.02	.00	.02	0.
1	JAN	1800	25	.03	.03	.00	0.	*	2	JAN	1015	90	.02	.00	.02	0.
1	JAN	1815	26	.04	.04	.00	0.	*	2	JAN	1030	91	.02	.00	.02	0.
1	JAN	1830	27	.04	.04	.00	0.	*	2	JAN	1045	92	.02	.00	.02	0.
1	JAN	1845	28	.04	.04	.00	0.	*	2	JAN	1100	93	.02	.00	.02	0.
1	JAN	1900	29	.04	.04	.00	0.	*	2	JAN	1115	94	.02	.00	.02	0.
1	JAN	1915	30	.04	.04	.00	0.	*	2	JAN	1130	95	.02	.00	.02	0.
1	JAN	1930	31	.04	.04	.00	0.	*	2	JAN	1145	96	.02	.00	.02	0.
1	JAN	1945	32	.04	.04	.00	0.	*	2	JAN	1200	97	.02	.00	.02	0.
1	JAN	2000	33	.04	.04	.00	0.	*	2	JAN	1215	98	.00	.00	.00	0.
1	JAN	2015	34	.05	.05	.01	0.	*	2	JAN	1230	99	.00	.00	.00	0.
1	JAN	2030	35	.05	.05	.01	0.	*	2	JAN	1245	100	.00	.00	.00	0.
1	JAN	2045	36	.05	.04	.01	0.	*	2	JAN	1300	101	.00	.00	.00	0.
1	JAN	2100	37	.05	.05	.01	0.	*	2	JAN	1315	102	.00	.00	.00	0.
1	JAN	2115	38	.06	.05	.01	0.	*	2	JAN	1330	103	.00	.00	.00	0.
1	JAN	2130	39	.06	.05	.01	0.	*	2	JAN	1345	104	.00	.00	.00	0.
1	JAN	2145	40	.07	.05	.02	0.	*	2	JAN	1400	105	.00	.00	.00	0.
1	JAN	2200	41	.07	.05	.02	0.	*	2	JAN	1415	106	.00	.00	.00	0.
1	JAN	2215	42	.09	.07	.03	0.	*	2	JAN	1430	107	.00	.00	.00	0.
1	JAN	2230	43	.09	.06	.03	0.	*	2	JAN	1445	108	.00	.00	.00	0.
1	JAN	2245	44	.12	.08	.04	1.	*	2	JAN	1500	109	.00	.00	.00	0.
1	JAN	2300	45	.12	.08	.04	1.	*	2	JAN	1515	110	.00	.00	.00	0.
1	JAN	2315	46	.19	.12	.07	1.	*	2	JAN	1530	111	.00	.00	.00	0.
1	JAN	2330	47	.19	.11	.08	1.	*	2	JAN	1545	112	.00	.00	.00	0.
1	JAN	2345	48	.81	.40	.41	5.	*	2	JAN	1600	113	.00	.00	.00	0.
2	JAN	0000	49	2.15	.71	1.44	17.	*	2	JAN	1615	114	.00	.00	.00	0.
2	JAN	0015	50	.28	.07	.21	15.	*	2	JAN	1630	115	.00	.00	.00	0.
2	JAN	0030	51	.28	.06	.22	7.	*	2	JAN	1645	116	.00	.00	.00	0.
2	JAN	0045	52	.15	.03	.12	4.	*	2	JAN	1700	117	.00	.00	.00	0.
2	JAN	0100	53	.14	.03	.11	3.	*	2	JAN	1715	118	.00	.00	.00	0.

2 JAN 0115	54	.11	.02	.09	2.	*	2 JAN 1730	119	.00	.00	.00	0.
2 JAN 0130	55	.10	.02	.08	2.	*	2 JAN 1745	120	.00	.00	.00	0.
2 JAN 0145	56	.09	.02	.07	2.	*	2 JAN 1800	121	.00	.00	.00	0.
2 JAN 0200	57	.08	.02	.06	1.	*	2 JAN 1815	122	.00	.00	.00	0.
2 JAN 0215	58	.06	.01	.05	1.	*	2 JAN 1830	123	.00	.00	.00	0.
2 JAN 0230	59	.05	.01	.04	1.	*	2 JAN 1845	124	.00	.00	.00	0.
2 JAN 0245	60	.06	.01	.05	1.	*	2 JAN 1900	125	.00	.00	.00	0.
2 JAN 0300	61	.05	.01	.04	1.	*	2 JAN 1915	126	.00	.00	.00	0.
2 JAN 0315	62	.06	.01	.05	1.	*	2 JAN 1930	127	.00	.00	.00	0.
2 JAN 0330	63	.05	.01	.04	1.	*	2 JAN 1945	128	.00	.00	.00	0.
2 JAN 0345	64	.06	.01	.05	1.	*	2 JAN 2000	129	.00	.00	.00	0.
2 JAN 0400	65	.05	.01	.04	1.	*						

TOTAL RAINFALL = 7.80, TOTAL LOSS = 3.36, TOTAL EXCESS = 4.44

PEAK FLOW (CFS)	TIME (HR)	MAXIMUM AVERAGE FLOW			
		6-HR	24-HR	72-HR	32.00-HR
17.	12.00	3.	1.	1.	1.
	(INCHES)	3.481	4.436	4.441	4.441
	(AC-FT)	1.	2.	2.	2.

CUMULATIVE AREA = .01 SQ MI

* *
78 KK * PD2&C *
* *

79 HC HYDROGRAPH COMBINATION
ICOMP 2 NUMBER OF HYDROGRAPHS TO COMBINE

HYDROGRAPH AT STATION PD2&C
SUM OF 2 HYDROGRAPHS
PLAN 1, RATIO = 7.80

DA	MON	HRMN	ORD	FLOW	*	DA	MON	HRMN	ORD	FLOW	*	DA	MON	HRMN	ORD	FLOW	*	DA	MON	HRMN	ORD	FLOW	*
1	JAN	1200	1	0.	*	1	JAN	2015	34	0.	*	2	JAN	0430	67	2.	*	2	JAN	1245	100	0.	*
		JAN 1215	2	0.	*			JAN 2030	35	0.	*			JAN 0445	68	2.	*			JAN 1300	101	0.	*
		JAN 1230	3	0.	*			JAN 2045	36	0.	*			JAN 0500	69	2.	*			JAN 1315	102	0.	*
		JAN 1245	4	0.	*			JAN 2100	37	0.	*			JAN 0515	70	2.	*			JAN 1330	103	0.	*
		JAN 1300	5	0.	*			JAN 2115	38	0.	*			JAN 0530	71	2.	*			JAN 1345	104	0.	*
		JAN 1315	6	0.	*			JAN 2130	39	0.	*			JAN 0545	72	2.	*			JAN 1400	105	0.	*

1 JAN 1330	7	0.	*	1 JAN 2145	40	0.	*	2 JAN 0600	73	2.	*	2 JAN 1415	106	0.
1 JAN 1345	8	0.	*	1 JAN 2200	41	0.	*	2 JAN 0615	74	2.	*	2 JAN 1430	107	0.
1 JAN 1400	9	0.	*	1 JAN 2215	42	1.	*	2 JAN 0630	75	2.	*	2 JAN 1445	108	0.
1 JAN 1415	10	0.	*	1 JAN 2230	43	1.	*	2 JAN 0645	76	2.	*	2 JAN 1500	109	0.
1 JAN 1430	11	0.	*	1 JAN 2245	44	1.	*	2 JAN 0700	77	2.	*	2 JAN 1515	110	0.
1 JAN 1445	12	0.	*	1 JAN 2300	45	1.	*	2 JAN 0715	78	2.	*	2 JAN 1530	111	0.
1 JAN 1500	13	0.	*	1 JAN 2315	46	1.	*	2 JAN 0730	79	2.	*	2 JAN 1545	112	0.
1 JAN 1515	14	0.	*	1 JAN 2330	47	2.	*	2 JAN 0745	80	1.	*	2 JAN 1600	113	0.
1 JAN 1530	15	0.	*	1 JAN 2345	48	5.	*	2 JAN 0800	81	1.	*	2 JAN 1615	114	0.
1 JAN 1545	16	0.	*	2 JAN 0000	49	19.	*	2 JAN 0815	82	1.	*	2 JAN 1630	115	0.
1 JAN 1600	17	0.	*	2 JAN 0015	50	19.	*	2 JAN 0830	83	1.	*	2 JAN 1645	116	0.
1 JAN 1615	18	0.	*	2 JAN 0030	51	13.	*	2 JAN 0845	84	1.	*	2 JAN 1700	117	0.
1 JAN 1630	19	0.	*	2 JAN 0045	52	10.	*	2 JAN 0900	85	1.	*	2 JAN 1715	118	0.
1 JAN 1645	20	0.	*	2 JAN 0100	53	8.	*	2 JAN 0915	86	1.	*	2 JAN 1730	119	0.
1 JAN 1700	21	0.	*	2 JAN 0115	54	7.	*	2 JAN 0930	87	1.	*	2 JAN 1745	120	0.
1 JAN 1715	22	0.	*	2 JAN 0130	55	6.	*	2 JAN 0945	88	1.	*	2 JAN 1800	121	0.
1 JAN 1730	23	0.	*	2 JAN 0145	56	5.	*	2 JAN 1000	89	1.	*	2 JAN 1815	122	0.
1 JAN 1745	24	0.	*	2 JAN 0200	57	5.	*	2 JAN 1015	90	1.	*	2 JAN 1830	123	0.
1 JAN 1800	25	0.	*	2 JAN 0215	58	4.	*	2 JAN 1030	91	1.	*	2 JAN 1845	124	0.
1 JAN 1815	26	0.	*	2 JAN 0230	59	4.	*	2 JAN 1045	92	1.	*	2 JAN 1900	125	0.
1 JAN 1830	27	0.	*	2 JAN 0245	60	3.	*	2 JAN 1100	93	1.	*	2 JAN 1915	126	0.
1 JAN 1845	28	0.	*	2 JAN 0300	61	3.	*	2 JAN 1115	94	1.	*	2 JAN 1930	127	0.
1 JAN 1900	29	0.	*	2 JAN 0315	62	3.	*	2 JAN 1130	95	1.	*	2 JAN 1945	128	0.
1 JAN 1915	30	0.	*	2 JAN 0330	63	3.	*	2 JAN 1145	96	1.	*	2 JAN 2000	129	0.
1 JAN 1930	31	0.	*	2 JAN 0345	64	3.	*	2 JAN 1200	97	1.	*			
1 JAN 1945	32	0.	*	2 JAN 0400	65	3.	*	2 JAN 1215	98	1.	*			
1 JAN 2000	33	0.	*	2 JAN 0415	66	2.	*	2 JAN 1230	99	1.	*			

PEAK FLOW (CFS)	TIME (HR)	MAXIMUM AVERAGE FLOW (CFS)				
		6-HR	24-HR	72-HR	32.00-HR	
19.	12.00	6.	2.	1.	1.	
		(INCHES)	3.222	4.388	4.435	4.435
		(AC-FT)	3.	4.	4.	4.

CUMULATIVE AREA = .02 SQ MI

*** **

* *
80 KK * POND1 *
* *

HYDROGRAPH ROUTING DATA

RS
STORAGE ROUTING
NSTPS 1 NUMBER OF SUBREACHES
ITYP ELEV TYPE OF INITIAL CONDITION
RSVRIC 1343.60 INITIAL CONDITION
X .00 WORKING R AND D COEFFICIENT

82 SA	AREA	.4	.4	.5	.6										
83 SE	ELEVATION	1351.60	1352.60	1353.60	1354.60										
○ SQ	DISCHARGE	0.	2.	4.	6.	8.	10.	11.	13.	15.	17.				
		19.													
86 SE	ELEVATION	1351.60	1351.85	1351.99	1352.11	1352.22	1352.32	1352.42	1352.51	1352.59	1352.67				
		1352.75													

COMPUTED STORAGE-ELEVATION DATA

STORAGE	.00	.41	.88	1.43
ELEVATION	1351.60	1352.60	1353.60	1354.60

COMPUTED STORAGE-OUTFLOW-ELEVATION DATA

STORAGE	.00	.10	.15	.20	.25	.29	.33	.37	.41	.41
OUTFLOW	.00	1.90	3.80	5.70	7.60	9.50	11.40	13.30	15.20	15.44
ELEVATION	1351.60	1351.85	1351.99	1352.11	1352.22	1352.32	1352.42	1352.51	1352.59	1352.60
STORAGE	.44	.48	.88	1.43						
OUTFLOW	17.10	19.00	39.20	62.96						
ELEVATION	1352.67	1352.75	1353.60	1354.60						

HYDROGRAPH AT STATION POND1
PLAN 1, RATIO = 7.80

* * * * *																						
DA	MON	HRMN	ORD	OUTFLOW	STORAGE	STAGE	*	DA	MON	HRMN	ORD	OUTFLOW	STORAGE	STAGE	*	DA	MON	HRMN	ORD	OUTFLOW	STORAGE	STAGE
* * * * *																						
1	JAN	1200	1	0.	.0	1351.6	*	1	JAN	2245	44	1.	.0	1351.7	*	2	JAN	0930	87	1.	.1	1351.8
1	JAN	1215	2	0.	.0	1351.6	*	1	JAN	2300	45	1.	.0	1351.7	*	2	JAN	0945	88	1.	.1	1351.7
1	JAN	1230	3	0.	.0	1351.6	*	1	JAN	2315	46	1.	.0	1351.7	*	2	JAN	1000	89	1.	.1	1351.7
1	JAN	1245	4	0.	.0	1351.6	*	1	JAN	2330	47	1.	.1	1351.8	*	2	JAN	1015	90	1.	.1	1351.7
1	JAN	1300	5	0.	.0	1351.6	*	1	JAN	2345	48	2.	.1	1351.9	*	2	JAN	1030	91	1.	.1	1351.7
1	JAN	1315	6	0.	.0	1351.6	*	2	JAN	0000	49	8.	.2	1352.2	*	2	JAN	1045	92	1.	.1	1351.7
1	JAN	1330	7	0.	.0	1351.6	*	2	JAN	0015	50	15.	.4	1352.6	*	2	JAN	1100	93	1.	.1	1351.7
1	JAN	1345	8	0.	.0	1351.6	*	2	JAN	0030	51	15.	.4	1352.6	*	2	JAN	1115	94	1.	.1	1351.7
1	JAN	1400	9	0.	.0	1351.6	*	2	JAN	0045	52	12.	.4	1352.5	*	2	JAN	1130	95	1.	.0	1351.7
1	JAN	1415	10	0.	.0	1351.6	*	2	JAN	0100	53	10.	.3	1352.3	*	2	JAN	1145	96	1.	.0	1351.7
1	JAN	1430	11	0.	.0	1351.6	*	2	JAN	0115	54	8.	.3	1352.3	*	2	JAN	1200	97	1.	.0	1351.7
1	JAN	1445	12	0.	.0	1351.6	*	2	JAN	0130	55	7.	.2	1352.2	*	2	JAN	1215	98	1.	.0	1351.7
1	JAN	1500	13	0.	.0	1351.6	*	2	JAN	0145	56	6.	.2	1352.1	*	2	JAN	1230	99	1.	.0	1351.7
1	JAN	1515	14	0.	.0	1351.6	*	2	JAN	0200	57	5.	.2	1352.1	*	2	JAN	1245	100	1.	.0	1351.7
1	JAN	1530	15	0.	.0	1351.6	*	2	JAN	0215	58	5.	.2	1352.1	*	2	JAN	1300	101	1.	.0	1351.7
1	JAN	1545	16	0.	.0	1351.6	*	2	JAN	0230	59	4.	.2	1352.0	*	2	JAN	1315	102	1.	.0	1351.7
1	JAN	1600	17	0.	.0	1351.6	*	2	JAN	0245	60	4.	.2	1352.0	*	2	JAN	1330	103	0.	.0	1351.7
1	JAN	1615	18	0.	.0	1351.6	*	2	JAN	0300	61	4.	.1	1352.0	*	2	JAN	1345	104	0.	.0	1351.7
1	JAN	1630	19	0.	.0	1351.6	*	2	JAN	0315	62	3.	.1	1352.0	*	2	JAN	1400	105	0.	.0	1351.6
1	JAN	1645	20	0.	.0	1351.6	*	2	JAN	0330	63	3.	.1	1351.9	*	2	JAN	1415	106	0.	.0	1351.6
1	JAN	1700	21	0.	.0	1351.6	*	2	JAN	0345	64	3.	.1	1351.9	*	2	JAN	1430	107	0.	.0	1351.6
1	JAN	1715	22	0.	.0	1351.6	*	2	JAN	0400	65	3.	.1	1351.9	*	2	JAN	1445	108	0.	.0	1351.6
1	JAN	1730	23	0.	.0	1351.6	*	2	JAN	0415	66	3.	.1	1351.9	*	2	JAN	1500	109	0.	.0	1351.6
1	JAN	1745	24	0.	.0	1351.6	*	2	JAN	0430	67	3.	.1	1351.9	*	2	JAN	1515	110	0.	.0	1351.6

1 JAN 1800	25	0.	.0	1351.6 *	2 JAN 0445	68	2.	.1	1351.9 *	2 JAN 1530	111	0.	.0	1351.6
1 JAN 1815	26	0.	.0	1351.6 *	2 JAN 0500	69	2.	.1	1351.9 *	2 JAN 1545	112	0.	.0	1351.6
1 JAN 1830	27	0.	.0	1351.6 *	2 JAN 0515	70	2.	.1	1351.9 *	2 JAN 1600	113	0.	.0	1351.6
1 JAN 1845	28	0.	.0	1351.6 *	2 JAN 0530	71	2.	.1	1351.9 *	2 JAN 1615	114	0.	.0	1351.6
1 JAN 1900	29	0.	.0	1351.6 *	2 JAN 0545	72	2.	.1	1351.8 *	2 JAN 1630	115	0.	.0	1351.6
1 JAN 1915	30	0.	.0	1351.6 *	2 JAN 0600	73	2.	.1	1351.8 *	2 JAN 1645	116	0.	.0	1351.6
1 JAN 1930	31	0.	.0	1351.6 *	2 JAN 0615	74	2.	.1	1351.8 *	2 JAN 1700	117	0.	.0	1351.6
1 JAN 1945	32	0.	.0	1351.6 *	2 JAN 0630	75	2.	.1	1351.8 *	2 JAN 1715	118	0.	.0	1351.6
1 JAN 2000	33	0.	.0	1351.6 *	2 JAN 0645	76	2.	.1	1351.8 *	2 JAN 1730	119	0.	.0	1351.6
1 JAN 2015	34	0.	.0	1351.6 *	2 JAN 0700	77	2.	.1	1351.8 *	2 JAN 1745	120	0.	.0	1351.6
1 JAN 2030	35	0.	.0	1351.6 *	2 JAN 0715	78	2.	.1	1351.8 *	2 JAN 1800	121	0.	.0	1351.6
1 JAN 2045	36	0.	.0	1351.6 *	2 JAN 0730	79	2.	.1	1351.8 *	2 JAN 1815	122	0.	.0	1351.6
1 JAN 2100	37	0.	.0	1351.6 *	2 JAN 0745	80	2.	.1	1351.8 *	2 JAN 1830	123	0.	.0	1351.6
1 JAN 2115	38	0.	.0	1351.6 *	2 JAN 0800	81	2.	.1	1351.8 *	2 JAN 1845	124	0.	.0	1351.6
1 JAN 2130	39	0.	.0	1351.6 *	2 JAN 0815	82	1.	.1	1351.8 *	2 JAN 1900	125	0.	.0	1351.6
1 JAN 2145	40	0.	.0	1351.6 *	2 JAN 0830	83	1.	.1	1351.8 *	2 JAN 1915	126	0.	.0	1351.6
1 JAN 2200	41	0.	.0	1351.6 *	2 JAN 0845	84	1.	.1	1351.8 *	2 JAN 1930	127	0.	.0	1351.6
1 JAN 2215	42	0.	.0	1351.7 *	2 JAN 0900	85	1.	.1	1351.8 *	2 JAN 1945	128	0.	.0	1351.6
1 JAN 2230	43	0.	.0	1351.7 *	2 JAN 0915	86	1.	.1	1351.8 *	2 JAN 2000	129	0.	.0	1351.6

*

*

PEAK FLOW + (CFS)	TIME (HR)	MAXIMUM AVERAGE FLOW			
		6-HR	24-HR	72-HR	32.00-HR
15.	12.50	5.	2.	1.	1.
	(INCHES)	3.184	4.386	4.433	4.433
	(AC-FT)	3.	4.	4.	4.

PEAK STORAGE + (AC-FT)	TIME (HR)	MAXIMUM AVERAGE STORAGE			
		6-HR	24-HR	72-HR	32.00-HR
0.	12.50	0.	0.	0.	0.

PEAK STAGE + (FEET)	TIME (HR)	MAXIMUM AVERAGE STAGE			
		6-HR	24-HR	72-HR	32.00-HR
1352.60	12.50	1352.07	1351.79	1351.74	1351.74

CUMULATIVE AREA = .02 SQ MI

*** **

* *
88 KK * BSNE *
* *

IN TIME DATA FOR INPUT TIME SERIES
JXMIN 15 TIME INTERVAL IN MINUTES
JXDATE 1JAN 3 STARTING DATE
JXTIME 1200 STARTING TIME

SUBBASIN RUNOFF DATA

89 BA SUBBASIN CHARACTERISTICS
 TAREA .00 SUBBASIN AREA

PRECIPITATION DATA

90 PB STORM 1.00 BASIN TOTAL PRECIPITATION

91 PI INCREMENTAL PRECIPITATION PATTERN

.00	.00	.00	.00	.00	.00	.00	.00	.00	.00	.00
.00	.00	.00	.00	.00	.00	.00	.00	.00	.00	.00
.00	.00	.00	.00	.01	.01	.00	.01	.00	.01	.01
.01	.00	.01	.01	.01	.01	.01	.01	.01	.01	.01
.01	.01	.02	.02	.02	.02	.10	.28	.04	.04	.04
.02	.02	.01	.01	.01	.01	.01	.01	.01	.01	.01
.01	.01	.01	.01	.00	.00	.00	.00	.00	.00	.00
.00	.00	.00	.00	.00	.00	.00	.00	.00	.00	.00
.00	.00	.00	.00	.00	.00	.00	.00	.00	.00	.00
.00	.00	.00	.00	.00	.00	.00	.00	.00	.00	.00

101 LS SCS LOSS RATE
 STRTL .94 INITIAL ABSTRACTION
 CRVNBR 68.00 CURVE NUMBER
 RTIMP 10.00 PERCENT IMPERVIOUS AREA

102 UD SCS DIMENSIONLESS UNITGRAPH
 TLAG .18 LAG

WARNING *** TIME INTERVAL IS GREATER THAN .29*LAG

UNIT HYDROGRAPH
 6 END-OF-PERIOD ORDINATES

6. 3. 1. 0. 0. 0.

HYDROGRAPH AT STATION BSNE

DA	MON	HRMN	ORD	RAIN	LOSS	EXCESS	COMP Q	*	DA	MON	HRMN	ORD	RAIN	LOSS	EXCESS	COMP Q
1	JAN	1200	1	.00	.00	.00	0.	*	2	JAN	0415	66	.00	.00	.00	0.
1	JAN	1215	2	.00	.00	.00	0.	*	2	JAN	0430	67	.00	.00	.00	0.
1	JAN	1230	3	.00	.00	.00	0.	*	2	JAN	0445	68	.00	.00	.00	0.
1	JAN	1245	4	.00	.00	.00	0.	*	2	JAN	0500	69	.00	.00	.00	0.
1	JAN	1300	5	.00	.00	.00	0.	*	2	JAN	0515	70	.00	.00	.00	0.
1	JAN	1315	6	.00	.00	.00	0.	*	2	JAN	0530	71	.00	.00	.00	0.
1	JAN	1330	7	.00	.00	.00	0.	*	2	JAN	0545	72	.00	.00	.00	0.
1	JAN	1345	8	.00	.00	.00	0.	*	2	JAN	0600	73	.00	.00	.00	0.
1	JAN	1400	9	.00	.00	.00	0.	*	2	JAN	0615	74	.00	.00	.00	0.
1	JAN	1415	10	.00	.00	.00	0.	*	2	JAN	0630	75	.00	.00	.00	0.
1	JAN	1430	11	.00	.00	.00	0.	*	2	JAN	0645	76	.00	.00	.00	0.
1	JAN	1445	12	.00	.00	.00	0.	*	2	JAN	0700	77	.00	.00	.00	0.
1	JAN	1500	13	.00	.00	.00	0.	*	2	JAN	0715	78	.00	.00	.00	0.
1	JAN	1515	14	.00	.00	.00	0.	*	2	JAN	0730	79	.00	.00	.00	0.
1	JAN	1530	15	.00	.00	.00	0.	*	2	JAN	0745	80	.00	.00	.00	0.
1	JAN	1545	16	.00	.00	.00	0.	*	2	JAN	0800	81	.00	.00	.00	0.

1 JAN 1600	17	.00	.00	.00	0.	*	2 JAN 0815	82	.00	.00	.00	0.
1 JAN 1615	18	.00	.00	.00	0.	*	2 JAN 0830	83	.00	.00	.00	0.
1 JAN 1630	19	.00	.00	.00	0.	*	2 JAN 0845	84	.00	.00	.00	0.
1 JAN 1645	20	.00	.00	.00	0.	*	2 JAN 0900	85	.00	.00	.00	0.
1 JAN 1700	21	.00	.00	.00	0.	*	2 JAN 0915	86	.00	.00	.00	0.
1 JAN 1715	22	.00	.00	.00	0.	*	2 JAN 0930	87	.00	.00	.00	0.
1 JAN 1730	23	.00	.00	.00	0.	*	2 JAN 0945	88	.00	.00	.00	0.
1 JAN 1745	24	.00	.00	.00	0.	*	2 JAN 1000	89	.00	.00	.00	0.
1 JAN 1800	25	.00	.00	.00	0.	*	2 JAN 1015	90	.00	.00	.00	0.
1 JAN 1815	26	.01	.00	.00	0.	*	2 JAN 1030	91	.00	.00	.00	0.
1 JAN 1830	27	.01	.00	.00	0.	*	2 JAN 1045	92	.00	.00	.00	0.
1 JAN 1845	28	.00	.00	.00	0.	*	2 JAN 1100	93	.00	.00	.00	0.
1 JAN 1900	29	.01	.00	.00	0.	*	2 JAN 1115	94	.00	.00	.00	0.
1 JAN 1915	30	.00	.00	.00	0.	*	2 JAN 1130	95	.00	.00	.00	0.
1 JAN 1930	31	.01	.00	.00	0.	*	2 JAN 1145	96	.00	.00	.00	0.
1 JAN 1945	32	.01	.00	.00	0.	*	2 JAN 1200	97	.00	.00	.00	0.
1 JAN 2000	33	.00	.00	.00	0.	*	2 JAN 1215	98	.00	.00	.00	0.
1 JAN 2015	34	.01	.01	.00	0.	*	2 JAN 1230	99	.00	.00	.00	0.
1 JAN 2030	35	.01	.01	.00	0.	*	2 JAN 1245	100	.00	.00	.00	0.
1 JAN 2045	36	.01	.01	.00	0.	*	2 JAN 1300	101	.00	.00	.00	0.
1 JAN 2100	37	.01	.01	.00	0.	*	2 JAN 1315	102	.00	.00	.00	0.
1 JAN 2115	38	.01	.01	.00	0.	*	2 JAN 1330	103	.00	.00	.00	0.
1 JAN 2130	39	.01	.01	.00	0.	*	2 JAN 1345	104	.00	.00	.00	0.
1 JAN 2145	40	.01	.01	.00	0.	*	2 JAN 1400	105	.00	.00	.00	0.
1 JAN 2200	41	.01	.01	.00	0.	*	2 JAN 1415	106	.00	.00	.00	0.
1 JAN 2215	42	.01	.01	.00	0.	*	2 JAN 1430	107	.00	.00	.00	0.
1 JAN 2230	43	.01	.01	.00	0.	*	2 JAN 1445	108	.00	.00	.00	0.
1 JAN 2245	44	.02	.01	.00	0.	*	2 JAN 1500	109	.00	.00	.00	0.
1 JAN 2300	45	.02	.01	.00	0.	*	2 JAN 1515	110	.00	.00	.00	0.
1 JAN 2315	46	.02	.02	.00	0.	*	2 JAN 1530	111	.00	.00	.00	0.
1 JAN 2330	47	.02	.02	.00	0.	*	2 JAN 1545	112	.00	.00	.00	0.
1 JAN 2345	48	.10	.09	.01	0.	*	2 JAN 1600	113	.00	.00	.00	0.
2 JAN 0000	49	.28	.25	.03	0.	*	2 JAN 1615	114	.00	.00	.00	0.
2 JAN 0015	50	.04	.03	.00	0.	*	2 JAN 1630	115	.00	.00	.00	0.
2 JAN 0030	51	.04	.03	.00	0.	*	2 JAN 1645	116	.00	.00	.00	0.
2 JAN 0045	52	.02	.02	.00	0.	*	2 JAN 1700	117	.00	.00	.00	0.
2 JAN 0100	53	.02	.02	.00	0.	*	2 JAN 1715	118	.00	.00	.00	0.
2 JAN 0115	54	.01	.01	.00	0.	*	2 JAN 1730	119	.00	.00	.00	0.
2 JAN 0130	55	.01	.01	.00	0.	*	2 JAN 1745	120	.00	.00	.00	0.
2 JAN 0145	56	.01	.01	.00	0.	*	2 JAN 1800	121	.00	.00	.00	0.
2 JAN 0200	57	.01	.01	.00	0.	*	2 JAN 1815	122	.00	.00	.00	0.
2 JAN 0215	58	.01	.01	.00	0.	*	2 JAN 1830	123	.00	.00	.00	0.
2 JAN 0230	59	.01	.01	.00	0.	*	2 JAN 1845	124	.00	.00	.00	0.
2 JAN 0245	60	.01	.01	.00	0.	*	2 JAN 1900	125	.00	.00	.00	0.
2 JAN 0300	61	.01	.01	.00	0.	*	2 JAN 1915	126	.00	.00	.00	0.
2 JAN 0315	62	.01	.01	.00	0.	*	2 JAN 1930	127	.00	.00	.00	0.
2 JAN 0330	63	.01	.01	.00	0.	*	2 JAN 1945	128	.00	.00	.00	0.
2 JAN 0345	64	.01	.01	.00	0.	*	2 JAN 2000	129	.00	.00	.00	0.
2 JAN 0400	65	.01	.01	.00	0.	*						

TOTAL RAINFALL = 1.00, TOTAL LOSS = .90, TOTAL EXCESS = .10

+ (CFS)	TIME (HR)	MAXIMUM AVERAGE FLOW (CFS)			
		6-HR	24-HR	72-HR	32.00-HR
+ 0.	12.00	0.	0.	0.	0.
	(INCHES)	.070	.100	.101	.101

(AC-FT) 0. 0. 0. 0.

CUMULATIVE AREA = .00 SQ MI

WARNING *** TIME INTERVAL IS GREATER THAN .29*LAG

HYDROGRAPH AT STATION BSNE
PLAN 1, RATIO = 7.80

DA	MON	HRMN	ORD	RAIN	LOSS	EXCESS	COMP Q	*	DA	MON	HRMN	ORD	RAIN	LOSS	EXCESS	COMP Q
1	JAN	1200	1	.00	.00	.00	0.	*	2	JAN	0415	66	.04	.01	.03	0.
1	JAN	1215	2	.02	.02	.00	0.	*	2	JAN	0430	67	.03	.01	.03	0.
1	JAN	1230	3	.02	.02	.00	0.	*	2	JAN	0445	68	.04	.01	.03	0.
1	JAN	1245	4	.02	.01	.00	0.	*	2	JAN	0500	69	.03	.01	.03	0.
1	JAN	1300	5	.02	.02	.00	0.	*	2	JAN	0515	70	.04	.01	.03	0.
1	JAN	1315	6	.02	.02	.00	0.	*	2	JAN	0530	71	.03	.01	.03	0.
1	JAN	1330	7	.02	.02	.00	0.	*	2	JAN	0545	72	.04	.01	.03	0.
1	JAN	1345	8	.02	.01	.00	0.	*	2	JAN	0600	73	.03	.01	.03	0.
1	JAN	1400	9	.02	.02	.00	0.	*	2	JAN	0615	74	.04	.01	.03	0.
1	JAN	1415	10	.02	.02	.00	0.	*	2	JAN	0630	75	.03	.01	.03	0.
1	JAN	1430	11	.03	.03	.00	0.	*	2	JAN	0645	76	.03	.01	.03	0.
1	JAN	1445	12	.02	.02	.00	0.	*	2	JAN	0700	77	.04	.01	.03	0.
1	JAN	1500	13	.02	.02	.00	0.	*	2	JAN	0715	78	.03	.01	.03	0.
1	JAN	1515	14	.02	.02	.00	0.	*	2	JAN	0730	79	.04	.01	.03	0.
1	JAN	1530	15	.03	.03	.00	0.	*	2	JAN	0745	80	.03	.01	.03	0.
1	JAN	1545	16	.02	.02	.00	0.	*	2	JAN	0800	81	.04	.01	.03	0.
1	JAN	1600	17	.02	.02	.00	0.	*	2	JAN	0815	82	.02	.00	.02	0.
1	JAN	1615	18	.03	.03	.00	0.	*	2	JAN	0830	83	.02	.00	.02	0.
1	JAN	1630	19	.03	.03	.00	0.	*	2	JAN	0845	84	.02	.00	.02	0.
1	JAN	1645	20	.03	.03	.00	0.	*	2	JAN	0900	85	.02	.00	.02	0.
1	JAN	1700	21	.03	.03	.00	0.	*	2	JAN	0915	86	.02	.00	.02	0.
1	JAN	1715	22	.03	.03	.00	0.	*	2	JAN	0930	87	.02	.00	.02	0.
1	JAN	1730	23	.03	.03	.00	0.	*	2	JAN	0945	88	.02	.00	.02	0.
1	JAN	1745	24	.03	.03	.00	0.	*	2	JAN	1000	89	.02	.00	.02	0.
1	JAN	1800	25	.03	.03	.00	0.	*	2	JAN	1015	90	.02	.00	.02	0.
1	JAN	1815	26	.04	.04	.00	0.	*	2	JAN	1030	91	.02	.00	.02	0.
1	JAN	1830	27	.04	.04	.00	0.	*	2	JAN	1045	92	.02	.00	.02	0.
1	JAN	1845	28	.04	.04	.00	0.	*	2	JAN	1100	93	.02	.00	.02	0.
1	JAN	1900	29	.04	.04	.00	0.	*	2	JAN	1115	94	.02	.00	.02	0.
1	JAN	1915	30	.04	.04	.00	0.	*	2	JAN	1130	95	.02	.00	.02	0.
1	JAN	1930	31	.04	.04	.00	0.	*	2	JAN	1145	96	.02	.00	.02	0.
1	JAN	1945	32	.04	.04	.00	0.	*	2	JAN	1200	97	.02	.00	.02	0.
1	JAN	2000	33	.04	.04	.00	0.	*	2	JAN	1215	98	.00	.00	.00	0.
1	JAN	2015	34	.05	.05	.01	0.	*	2	JAN	1230	99	.00	.00	.00	0.
1	JAN	2030	35	.05	.05	.01	0.	*	2	JAN	1245	100	.00	.00	.00	0.
1	JAN	2045	36	.05	.04	.01	0.	*	2	JAN	1300	101	.00	.00	.00	0.
1	JAN	2100	37	.05	.05	.01	0.	*	2	JAN	1315	102	.00	.00	.00	0.
1	JAN	2115	38	.06	.05	.01	0.	*	2	JAN	1330	103	.00	.00	.00	0.
1	JAN	2130	39	.06	.05	.01	0.	*	2	JAN	1345	104	.00	.00	.00	0.
1	JAN	2145	40	.07	.05	.02	0.	*	2	JAN	1400	105	.00	.00	.00	0.
1	JAN	2200	41	.07	.05	.02	0.	*	2	JAN	1415	106	.00	.00	.00	0.
1	JAN	2215	42	.09	.07	.03	0.	*	2	JAN	1430	107	.00	.00	.00	0.
1	JAN	2230	43	.09	.06	.03	0.	*	2	JAN	1445	108	.00	.00	.00	0.
1	JAN	2245	44	.12	.08	.04	0.	*	2	JAN	1500	109	.00	.00	.00	0.

1 JAN 2300	45	.12	.08	.04	0.	*	2 JAN 1515	110	.00	.00	.00	0.
1 JAN 2315	46	.19	.12	.07	1.	*	2 JAN 1530	111	.00	.00	.00	0.
1 JAN 2330	47	.19	.11	.08	1.	*	2 JAN 1545	112	.00	.00	.00	0.
1 JAN 2345	48	.81	.40	.41	3.	*	2 JAN 1600	113	.00	.00	.00	0.
2 JAN 0000	49	2.15	.71	1.44	10.	*	2 JAN 1615	114	.00	.00	.00	0.
2 JAN 0015	50	.28	.07	.21	6.	*	2 JAN 1630	115	.00	.00	.00	0.
2 JAN 0030	51	.28	.06	.22	3.	*	2 JAN 1645	116	.00	.00	.00	0.
2 JAN 0045	52	.15	.03	.12	2.	*	2 JAN 1700	117	.00	.00	.00	0.
2 JAN 0100	53	.14	.03	.11	1.	*	2 JAN 1715	118	.00	.00	.00	0.
2 JAN 0115	54	.11	.02	.09	1.	*	2 JAN 1730	119	.00	.00	.00	0.
2 JAN 0130	55	.10	.02	.08	1.	*	2 JAN 1745	120	.00	.00	.00	0.
2 JAN 0145	56	.09	.02	.07	1.	*	2 JAN 1800	121	.00	.00	.00	0.
2 JAN 0200	57	.08	.02	.06	1.	*	2 JAN 1815	122	.00	.00	.00	0.
2 JAN 0215	58	.06	.01	.05	1.	*	2 JAN 1830	123	.00	.00	.00	0.
2 JAN 0230	59	.05	.01	.04	1.	*	2 JAN 1845	124	.00	.00	.00	0.
2 JAN 0245	60	.06	.01	.05	1.	*	2 JAN 1900	125	.00	.00	.00	0.
2 JAN 0300	61	.05	.01	.04	0.	*	2 JAN 1915	126	.00	.00	.00	0.
2 JAN 0315	62	.06	.01	.05	1.	*	2 JAN 1930	127	.00	.00	.00	0.
2 JAN 0330	63	.05	.01	.04	0.	*	2 JAN 1945	128	.00	.00	.00	0.
2 JAN 0345	64	.06	.01	.05	1.	*	2 JAN 2000	129	.00	.00	.00	0.
2 JAN 0400	65	.05	.01	.04	0.	*						

TOTAL RAINFALL = 7.80, TOTAL LOSS = 3.36, TOTAL EXCESS = 4.44

PEAK FLOW (CFS)	TIME (HR)	MAXIMUM AVERAGE FLOW			
		6-HR	24-HR	72-HR	32.00-HR
10.	12.00	1.	0.	0.	0.
		(INCHES) 3.481	4.437	4.441	4.441
		(AC-FT) 1.	1.	1.	1.

CUMULATIVE AREA = .00 SQ MI

*** **

 * *
 103 KK * PD1&E *
 * *

104 HC HYDROGRAPH COMBINATION
 ICOMP 2 NUMBER OF HYDROGRAPHS TO COMBINE

HYDROGRAPH AT STATION PD1&E
 SUM OF 2 HYDROGRAPHS
 PLAN 1, RATIO = 7.80

DA	MON	HRMN	ORD	FLOW	*	DA	MON	HRMN	ORD	FLOW	*	DA	MON	HRMN	ORD	FLOW	*	DA	MON	HRMN	ORD	FLOW	*	
1	JAN	1200	1	0.	*	1	JAN	2015	34	0.	*	2	JAN	0430	67	3.	*	2	JAN	1245	100	1.	*	
1	JAN	1215	2	0.	*	1	JAN	2030	35	0.	*	2	JAN	0445	68	3.	*	2	JAN	1300	101	1.	*	
1	JAN	1230	3	0.	*	1	JAN	2045	36	0.	*	2	JAN	0500	69	2.	*	2	JAN	1315	102	1.	*	
1	JAN	1245	4	0.	*	1	JAN	2100	37	0.	*	2	JAN	0515	70	2.	*	2	JAN	1330	103	0.	*	
1	JAN	1300	5	0.	*	1	JAN	2115	38	0.	*	2	JAN	0530	71	2.	*	2	JAN	1345	104	0.	*	
1	JAN	1315	6	0.	*	1	JAN	2130	39	0.	*	2	JAN	0545	72	2.	*	2	JAN	1400	105	0.	*	
1	JAN	1330	7	0.	*	1	JAN	2145	40	0.	*	2	JAN	0600	73	2.	*	2	JAN	1415	106	0.	*	
1	JAN	1345	8	0.	*	1	JAN	2200	41	1.	*	2	JAN	0615	74	2.	*	2	JAN	1430	107	0.	*	
1	JAN	1400	9	0.	*	1	JAN	2215	42	1.	*	2	JAN	0630	75	2.	*	2	JAN	1445	108	0.	*	
1	JAN	1415	10	0.	*	1	JAN	2230	43	1.	*	2	JAN	0645	76	2.	*	2	JAN	1500	109	0.	*	
1	JAN	1430	11	0.	*	1	JAN	2245	44	1.	*	2	JAN	0700	77	2.	*	2	JAN	1515	110	0.	*	
1	JAN	1445	12	0.	*	1	JAN	2300	45	1.	*	2	JAN	0715	78	2.	*	2	JAN	1530	111	0.	*	
1	JAN	1500	13	0.	*	1	JAN	2315	46	1.	*	2	JAN	0730	79	2.	*	2	JAN	1545	112	0.	*	
1	JAN	1515	14	0.	*	1	JAN	2330	47	2.	*	2	JAN	0745	80	2.	*	2	JAN	1600	113	0.	*	
1	JAN	1530	15	0.	*	1	JAN	2345	48	5.	*	2	JAN	0800	81	2.	*	2	JAN	1615	114	0.	*	
1	JAN	1545	16	0.	*	2	JAN	0000	49	18.	*	2	JAN	0815	82	2.	*	2	JAN	1630	115	0.	*	
1	JAN	1600	17	0.	*	2	JAN	0015	50	21.	*	2	JAN	0830	83	2.	*	2	JAN	1645	116	0.	*	
1	JAN	1615	18	0.	*	2	JAN	0030	51	19.	*	2	JAN	0845	84	2.	*	2	JAN	1700	117	0.	*	
1	JAN	1630	19	0.	*	2	JAN	0045	52	14.	*	2	JAN	0900	85	1.	*	2	JAN	1715	118	0.	*	
1	JAN	1645	20	0.	*	2	JAN	0100	53	11.	*	2	JAN	0915	86	1.	*	2	JAN	1730	119	0.	*	
1	JAN	1700	21	0.	*	2	JAN	0115	54	9.	*	2	JAN	0930	87	1.	*	2	JAN	1745	120	0.	*	
1	JAN	1715	22	0.	*	2	JAN	0130	55	8.	*	2	JAN	0945	88	1.	*	2	JAN	1800	121	0.	*	
1	JAN	1730	23	0.	*	2	JAN	0145	56	7.	*	2	JAN	1000	89	1.	*	2	JAN	1815	122	0.	*	
1	JAN	1745	24	0.	*	2	JAN	0200	57	6.	*	2	JAN	1015	90	1.	*	2	JAN	1830	123	0.	*	
1	JAN	1800	25	0.	*	2	JAN	0215	58	5.	*	2	JAN	1030	91	1.	*	2	JAN	1845	124	0.	*	
1	JAN	1815	26	0.	*	2	JAN	0230	59	5.	*	2	JAN	1045	92	1.	*	2	JAN	1900	125	0.	*	
1	JAN	1830	27	0.	*	2	JAN	0245	60	4.	*	2	JAN	1100	93	1.	*	2	JAN	1915	126	0.	*	
1	JAN	1845	28	0.	*	2	JAN	0300	61	4.	*	2	JAN	1115	94	1.	*	2	JAN	1930	127	0.	*	
1	JAN	1900	29	0.	*	2	JAN	0315	62	4.	*	2	JAN	1130	95	1.	*	2	JAN	1945	128	0.	*	
1	JAN	1915	30	0.	*	2	JAN	0330	63	4.	*	2	JAN	1145	96	1.	*	2	JAN	2000	129	0.	*	
1	JAN	1930	31	0.	*	2	JAN	0345	64	3.	*	2	JAN	1200	97	1.	*							
1	JAN	1945	32	0.	*	2	JAN	0400	65	3.	*	2	JAN	1215	98	1.	*							
1	JAN	2000	33	0.	*	2	JAN	0415	66	3.	*	2	JAN	1230	99	1.	*							

PEAK FLOW (CFS)	TIME (HR)	MAXIMUM AVERAGE FLOW			
		6-HR	24-HR	72-HR	32.00-HR
21.	12.25	7.	2.	2.	2.
		(INCHES) 3.224	4.389	4.435	4.435
		(AC-FT) 3.	5.	5.	5.

CUMULATIVE AREA = .02 SQ MI

PEAK FLOW AND STAGE (END-OF-PERIOD) SUMMARY FOR MULTIPLE PLAN-RATIO ECONOMIC COMPUTATIONS
 FLOWS IN CUBIC FEET PER SECOND, AREA IN SQUARE MILES
 TIME TO PEAK IN HOURS

OPERATION	STATION	AREA	PLAN	RATIO 1
				7.80

RATIOS APPLIED TO PRECIPITATION

HYDROGRAPH AT

+	BSNA	.00	1	FLOW	11.
				TIME	12.00

 HYDROGRAPH AT

+	BSNB	.00	1	FLOW	3.
				TIME	12.00

HYDROGRAPH AT

+	BSND	.01	1	FLOW	16.
				TIME	12.00

2 COMBINED AT

+	B&D	.01	1	FLOW	19.
				TIME	12.00

ROUTED TO

+	POND2	.01	1	FLOW	5.
				TIME	12.75

** PEAK STAGES IN FEET **

1	STAGE	1354.22
	TIME	12.75

HYDROGRAPH AT

+	BSNC	.01	1	FLOW	17.
				TIME	12.00

 2 COMBINED AT

PD2&C	.02	1	FLOW	19.
			TIME	12.00

ROUTED TO

+	POND1	.02	1	FLOW	15.
				TIME	12.50

** PEAK STAGES IN FEET **

1	STAGE	1352.60
	TIME	12.50

HYDROGRAPH AT

+	BSNE	.00	1	FLOW	10.
				TIME	12.00

2 COMBINED AT

+	PD1&E	.02	1	FLOW	21.
				TIME	12.25

*** NORMAL END OF HEC-1 ***



100	j,	1347.0000	100	1	3						
110	t,	Savanna 10th SWS Line #1									
120	i,	102	0.00	0.00	0.00	0.00	0.00	2.51	15.00	1357.50	
130	m,	101	1351.50								
140	m,	100	1347.00								
150	p,	102	101	160.00	15	0.013	0.00	0.00			
160	p,	101	100	50.00	15	0.013	0.00	0.00			
170	e										

□

Input File: c:\storm\swsline1

Savanna 10th SWS Line #1

Storm Frequency = 2-Year

* * * H Y D R O L O G Y * * *

Tributary Area		Hydrology				Summation				Conduit Data						
Node	C	Area (Ac)	slope (%)	Length (FT)	TC (Min)	I(0) (In/Hr)	q(0) (CFS)	TC (Min)	I (In/Hr)	Q (CFS)	Sum Q (CFS)	Size	Velocity (Ft/Sec)	Length (FT)	TT (Min)	TT+TC (Min)
102	101	.00	.00	.0	15.00	3.83	2.51	15.00	3.83	2.51	2.51	15"	2.05	160.00	1.30	16.30
101	100	.00	.00	.0	16.30	3.68	.00	16.30	3.68	.00	2.51	15"	2.05	50.00	.41	16.71

STORM12.OUT

Date: 02-19-2004
Time: 16:20:08

Input File: c:\storm\swsline1

Savanna 10th SWS Line #1

Storm Frequency = 2-Year

* * * H Y D R A U L I C S * * *

```

*****
Node  Hyd-Slope  Friction  Bend  Transition  Manhole  Deflection  Junction  Total  Hyd-Gl  Desired  Diff.
      (Ft/Ft)    (Ft)      (Ft)    (Ft)      (Ft)      (Ft)      (Ft)      (Ft)      (Ft)      Elevation  Elevation  (Ft)
*****
102   .00151     .2416     .0000     .0000     .0000     .0000     .0000     .2416  1347.3280  1357.5000  10.17
101   .00151     .0755     .0000     .0000     .0032     .0000     .0076     .0863  1347.0860  1351.5000   4.41
100   .00000     .0000     .0000     .0000     .0000     .0000     .0000     .0000  1347.0000  1347.0000   .00
*****

```

100	j,	1347.0000	200	1	3	2					
110	t,	Savanna 10th SWS Line #2									
120	i,	202	0.00	0.00	0.00	0.00	2.85	15.00	1356.00		
130	m,	201	1351.50								
140	m,	200	1347.00								
150	p,	202	201	175.00	15	0.013	0.00	0.00			
160	p,	201	200	60.00	15	0.013	0.00	0.00			
170	e										

□

Input File: c:\storm\swsline2

Savanna 10th SWS Line #2

Storm Frequency = 2-Year

* * * H Y D R O L O G Y * * *

Tributary Area		Hydrology Summation				Conduit Data						
Node	Area (AC)	TC (Min)	I (In/Hr)	Q (CFS)	TC (Min)	I (In/Hr)	Q (CFS)	Size	Velocity (Ft/Sec)	Length (FT)	TT (Min)	TT+TC (Min)
202	201 .00	.00	3.83	2.85	15.00	3.83	2.85	15"	2.32	175.00	1.26	16.26
201	200 .00	.00	.00	.00	16.26	3.69	.00	15"	2.32	60.00	.43	16.69

STORM12.OUT

Date: 02-19-2004
Time: 16:21:32

Input File: c:\storm\swsline2

Savanna 10th SWS Line #2

Storm Frequency = 2-Year

* * * H Y D R A U L I C S * * *

```

*****
Hyd-Slope (Ft/Ft) Friction (Ft) Bend (Ft) Transition (Ft) Manhole (Ft) Deflection (Ft) Junction (Ft) Total (Ft) Hyd-G1 Elevation (Ft) Desired Diff. (Ft)
*****
202 .00195 .3406 .0000 .0000 .0000 .0000 .0000 .0000 .3406 1347.4710 1356.0000 8.53
201 .00195 .1168 .0000 .0000 .0042 .0000 .0097 .1307 1347.1310 1351.5000 4.37
200 .00000 .0000 .0000 .0000 .0000 .0000 .0000 .0000 1347.0000 1347.0000 1347.0000 .00
*****

```

SWSLINE3

100 j, 1349.0000 300 1 4 3
110 t, Savanna 10th SWS Line #3
120 i, 303 0.00 0.00 0.00 0.00 2.63 15.00 1360.50
130 m, 302 1361.50
140 m, 301 1361.25
150 m, 300 1349.00
160 p, 303 302 270.00 15 0.013 0.00 0.00
170 p, 302 301 30.00 15 0.013 0.00 30.00
180 p, 301 300 90.00 15 0.013 0.00 30.00
190 e

STORM11.OUT

Date: 02-19-2004
Time: 13:44:08

Input File: c:\storm\swsline3

Savanna 10th SWS Line #3

Storm Frequency = 2-Year

* * * H Y D R O L O G Y * * *

```

*****
***** Tributary Area *****
***** C Area Slope Length TC(0) I(0) Q(0) *****
***** (AC) (%) (Ft) (Min) (In/Hr) (CFS) *****
3 302 .00 .00 .0 15.00 3.83 2.63 2.63 2.63 2.63
2 301 .00 .00 .0 .00 .00 .00 17.10 3.60 .00 2.63
L 300 .00 .00 .0 .00 .00 .00 17.33 3.58 .00 2.63
*****
***** Hydrology Summation *****
***** TC I Q Sum Q *****
***** (Min) (In/Hr) (CFS) (CFS) *****
3 302 .00 .00 .0 15.00 3.83 2.63 2.63 2.63
2 301 .00 .00 .0 .00 .00 .00 17.10 3.60 .00 2.63
L 300 .00 .00 .0 .00 .00 .00 17.33 3.58 .00 2.63
*****
***** Conduit Data *****
***** Size Velocity Length TT TT+TC *****
***** (In) (Ft/Sec) (Ft) (Min) (Min) *****
3 302 15" 2.14 270.00 2.10 17.10
2 301 15" 2.14 30.00 .23 17.33
L 300 15" 2.14 90.00 .70 18.03
*****

```

Date: 02-19-2004
Time: 13:44:08

STORM12.OUT

Input File: c:\storm\swsline3

Savanna 10th SWS Line #3

Storm Frequency = 2-Year

* * * H Y D R A U L I C S * * *

Node	Hyd-Slope (Ft/Ft)	Friction (Ft)	Bend (Ft)	Transition (Ft)	Manhole (Ft)	Deflection (Ft)	Junction (Ft)	Total (Ft)	Hyd-GI Elevation	Desired Elevation	Diff.
303	.00166	.4475	.0000	.0000	.0000	.0000	.0000	.4475	1349.6850	1360.5000	10.82
302	.00166	.0497	.0144	.0000	.0036	.0000	.0083	.0760	1349.2370	1361.5000	12.26
301	.00166	.1492	.0000	.0000	.0036	.0000	.0083	.1611	1349.1610	1361.2500	12.09
300	.00000	.0000	.0000	.0000	.0000	.0000	.0000	.0000	1349.0000	1349.0000	.00

KS-2-5

County	Expected 24-hour Storm Rainfall in Inches						Normal Annual Precipitation Inches
	Storm Frequency in Years						
	100	50	25	10	5	2	
Pawnee	6.6	6.0	5.2	4.5	3.7	2.8	23.3
Phillips	6.0	5.5	4.8	4.1	3.4	2.5	23.6
Pottawatomie	7.5	6.6	5.9	5.1	4.3	3.4	33.6
Pratt	7.2	6.4	5.6	4.8	4.1	3.0	24.6
Rawlins	5.5	5.0	4.3	3.6	3.1	2.3	21.0
Reno	7.4	6.6	5.8	5.0	4.2	3.2	27.7
Republic	6.8	6.0	5.4	4.6	3.9	2.9	28.6
Rice	7.3	6.4	5.6	4.8	4.1	3.0	26.6
Riley	7.4	6.5	5.8	5.1	4.3	3.3	33.5
Rooks	6.1	5.7	4.9	4.1	3.4	2.5	23.9
Rush	6.5	5.9	5.0	4.3	3.6	2.7	23.3
Russell	6.7	5.9	5.2	4.4	3.7	2.8	26.8
Saline	7.3	6.4	5.7	4.9	4.1	3.1	28.4
Scott	5.7	5.3	4.5	3.8	3.2	2.4	20.2
Sedgwick	7.8	7.0	6.1	5.3	4.5	3.5	30.6
Seward	6.0	5.7	4.8	4.2	3.5	2.6	19.8
Shawnee	7.8	6.8	6.1	5.3	4.5	3.5	34.7
Sheridan	5.7	5.3	4.5	3.8	3.2	2.4	21.3
Sherman	5.3	4.8	4.2	3.5	3.0	2.2	16.7
Smith	6.3	5.7	5.0	4.2	3.5	2.6	24.4
Stafford	7.1	6.2	5.5	4.7	4.0	2.9	25.1
Stanton	5.6	5.2	4.5	3.8	3.2	2.4	15.8
Stevens	5.9	5.5	4.7	4.1	3.4	2.5	19.7
Sumner	8.0	7.1	6.2	5.4	4.6	3.6	34.0

$x\text{-slope} = \frac{3}{8} \frac{1}{4} = 0.03125$

$z = \frac{1}{x\text{-slope}} = \frac{1}{0.03125} = 32$

$n = 0.016$

$\frac{z}{n} = \frac{32}{0.016} = 2000$

always

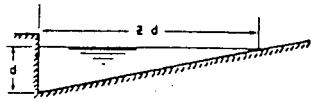

EQUATION: $Q = 0.56 \left(\frac{z}{n}\right) S^{1/2} d^{2.5}$

n IS ROUGHNESS COEFFICIENT IN MANNING
FORMULA APPROPRIATE TO MATERIAL IN
BOTTOM OF CHANNEL

z IS RECIPROCAL OF CROSS SLOPE

REFERENCE: H. R. B. PROCEEDINGS 1948,
PAGE 150, EQUATION (14)

EXAMPLE (SEE INSTRUCTION 1)

GIVEN: $S = 0.03$

$z = 24$

$n = .02$

$Q = 2.0 \text{ CFS}$

$z/n = 1200$

FIND: $d = 0.22$ BY FOLLOWING
DASHED LINES

RATIO z/n

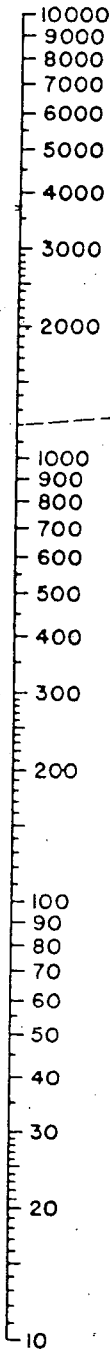

TURNING LINE

DISCHARGE (Q) IN CFS

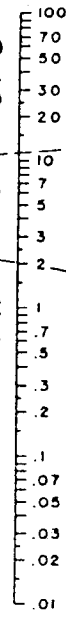

SLOPE OF CHANNEL (S) IN FT./FT.



DEPTH AT CURB OR DEEPEST POINT (d) IN FT.

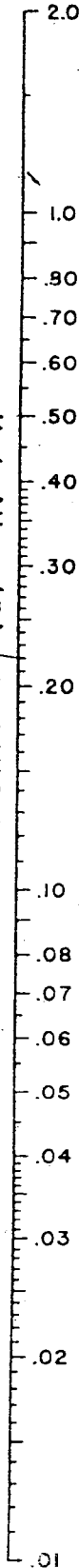

INSTRUCTIONS

1. CONNECT z/n RATIO WITH SLOPE (S)
AND CONNECT DISCHARGE (Q) WITH POINT
WHERE LINE CROSSES TURNING LINE READ DEPTH
AT CURB (d) Q CAN BE FOUND FROM d BY
CONNECTING d WITH CROSSING OF TURNING
LINE

2. FOR SHALLOW
V-SHAPED CHANNEL
AS SHOWN USE NOMOGRAPH AS EXPLAINED
IN INSTRUCTION 1 BUT WITH $z = \frac{T}{d}$

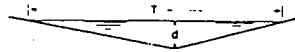

3. TO DETERMINE
DISCHARGE Q_0 IN
PORTION OF CHANNEL
HAVING WIDTH x :
DETERMINE DEPTH d FOR TOTAL DISCHARGE IN
ENTIRE SECTION AS EXPLAINED IN 1. THEN USE NOMOGRAPH TO
DETERMINE Q_0 IN SECTION OF WIDTH d FOR DEPTH
 $d' = d - \left(\frac{x}{2}\right)$ THEN $Q_0 = Q - Q_0$

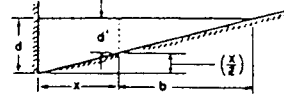

4. TO DETERMINE DISCHARGE
(Q_1) IN COMPOSITE SECTION:-
FOLLOW INSTRUCTION 3. TO
OBTAIN DISCHARGE (Q_0) IN
SECTION 0 AT ASSUMED DEPTH
 d BASED ON AN EXTENSION OF SLOPE RATIO z_0 TO
INTERSECT WATER SURFACE; OBTAIN Q_0 FOR SLOPE RATIO z_0
AND DEPTH d' ; $d' = d - \frac{x}{2}$ THEN $Q_1 = Q_0 + Q_0$

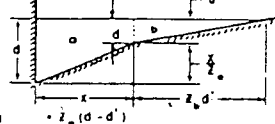

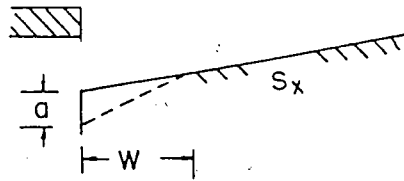

$$L_T = 0.6Q^{0.42} S^{0.3} (1/nS_x)^{0.6}$$

FOR COMPOSITE CROSS SLOPES, USE S_e FOR S_x .

$$S_e = S_x + S'_w E_o ; S'_w = a/w$$

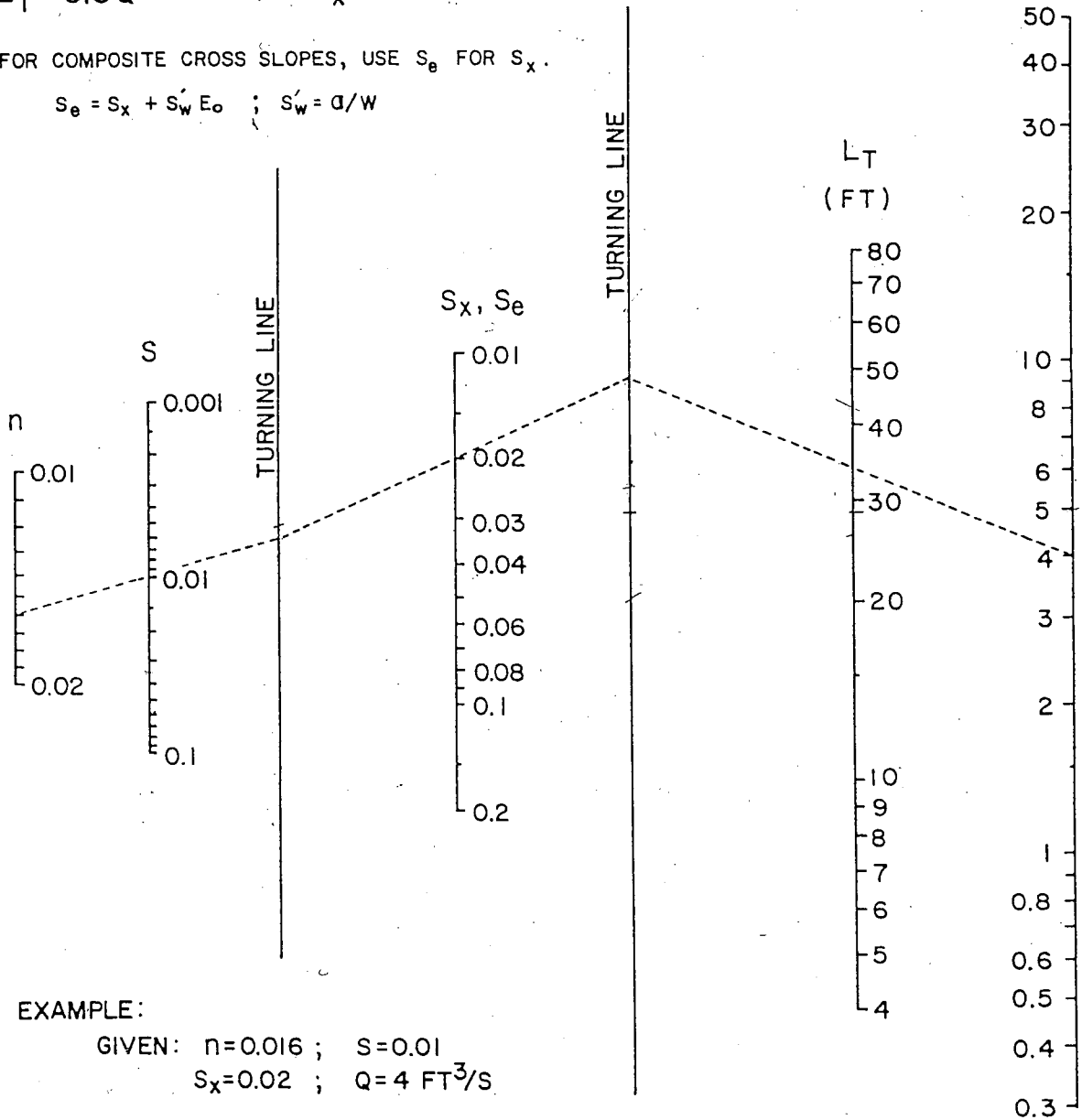

EXAMPLE:

GIVEN: $n=0.016$; $S=0.01$
 $S_x=0.02$; $Q=4 \text{ FT}^3/\text{S}$

FIND: $L_T = 34 \text{ FT}$

CHART 9. Curb-opening and slotted drain inlet length for total interception.

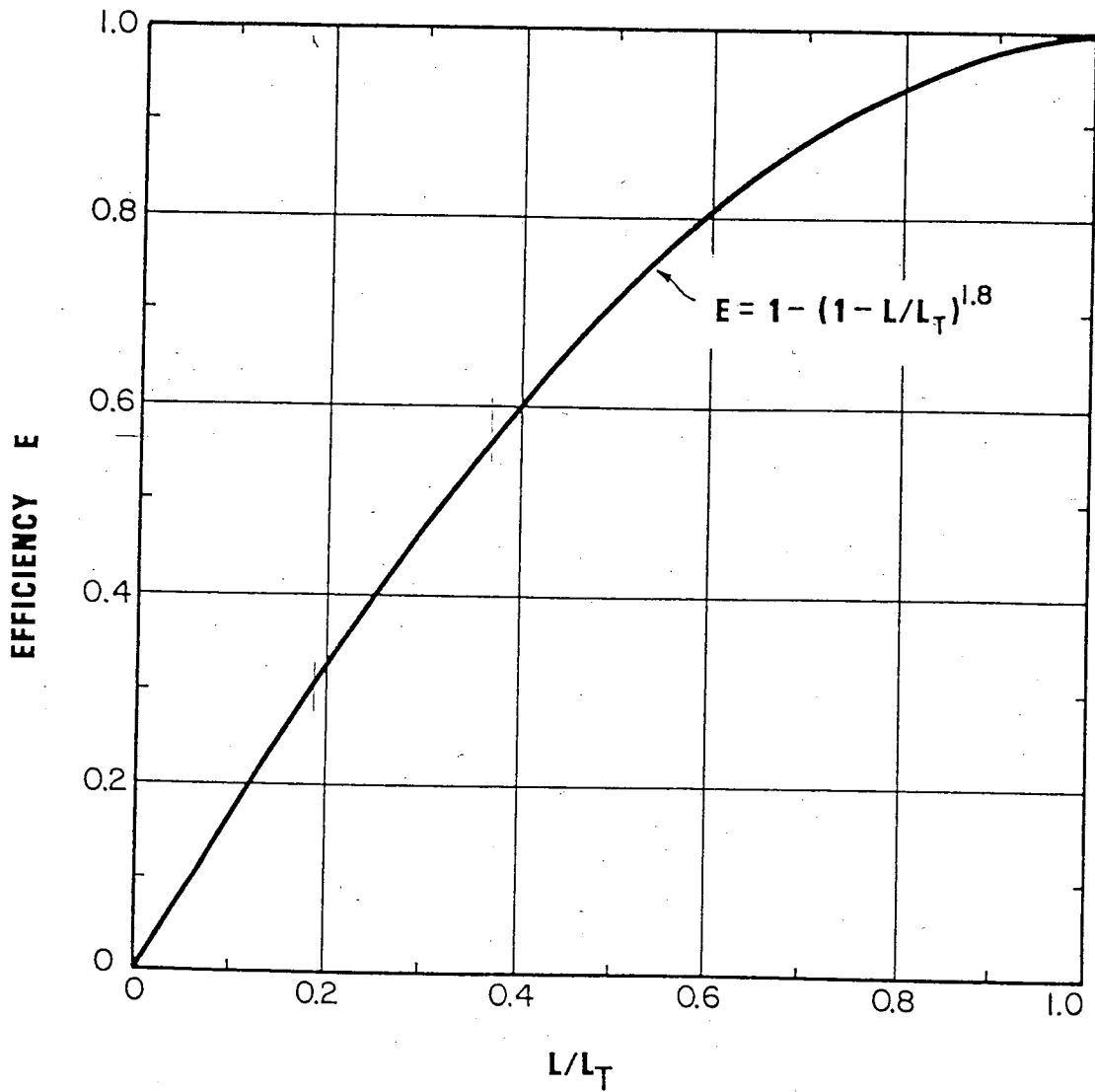

CHART 10. Curb-opening and slotted drain inlet interception efficiency.

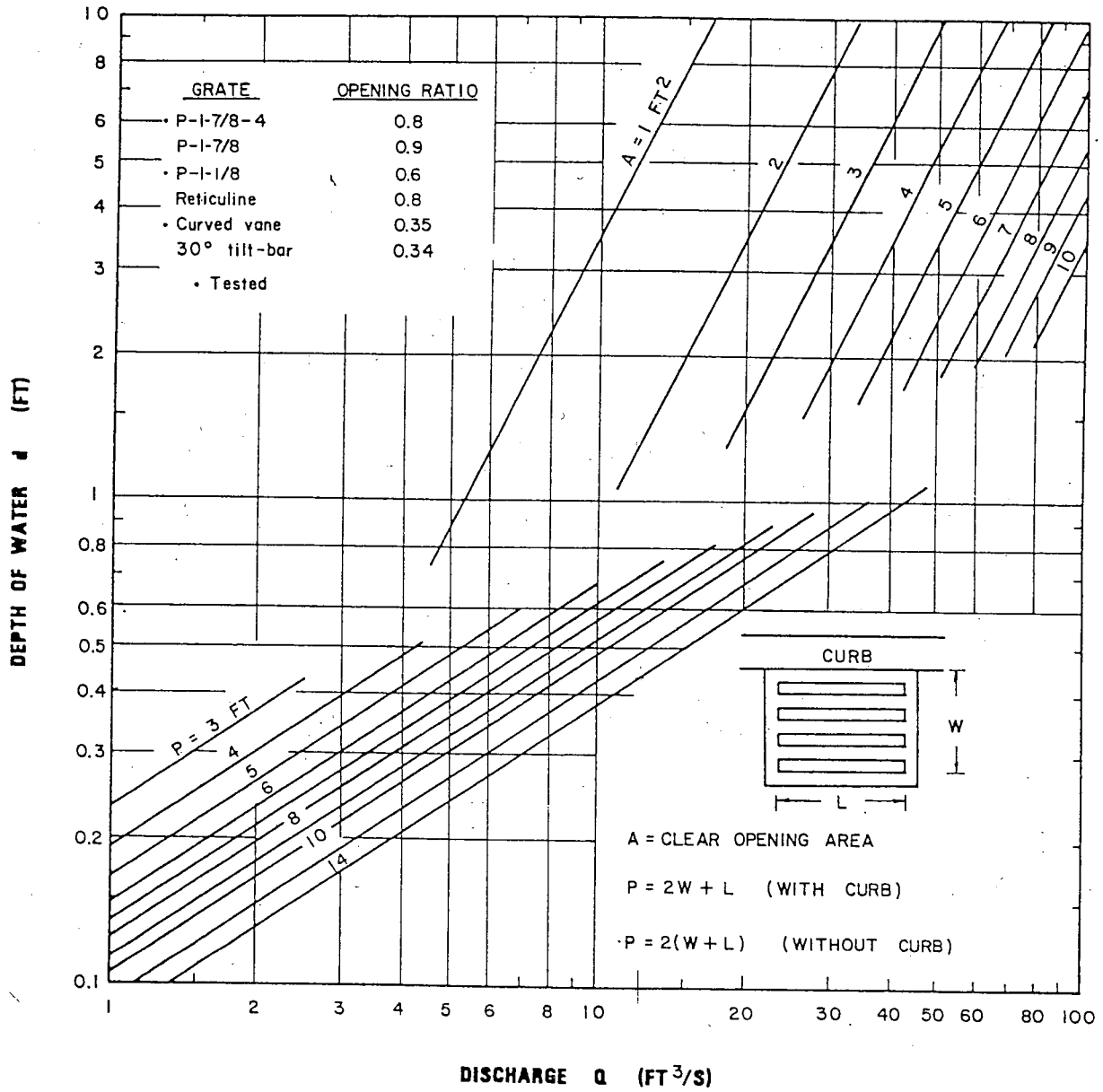

CHART 11. Grate inlet capacity in sump conditions.

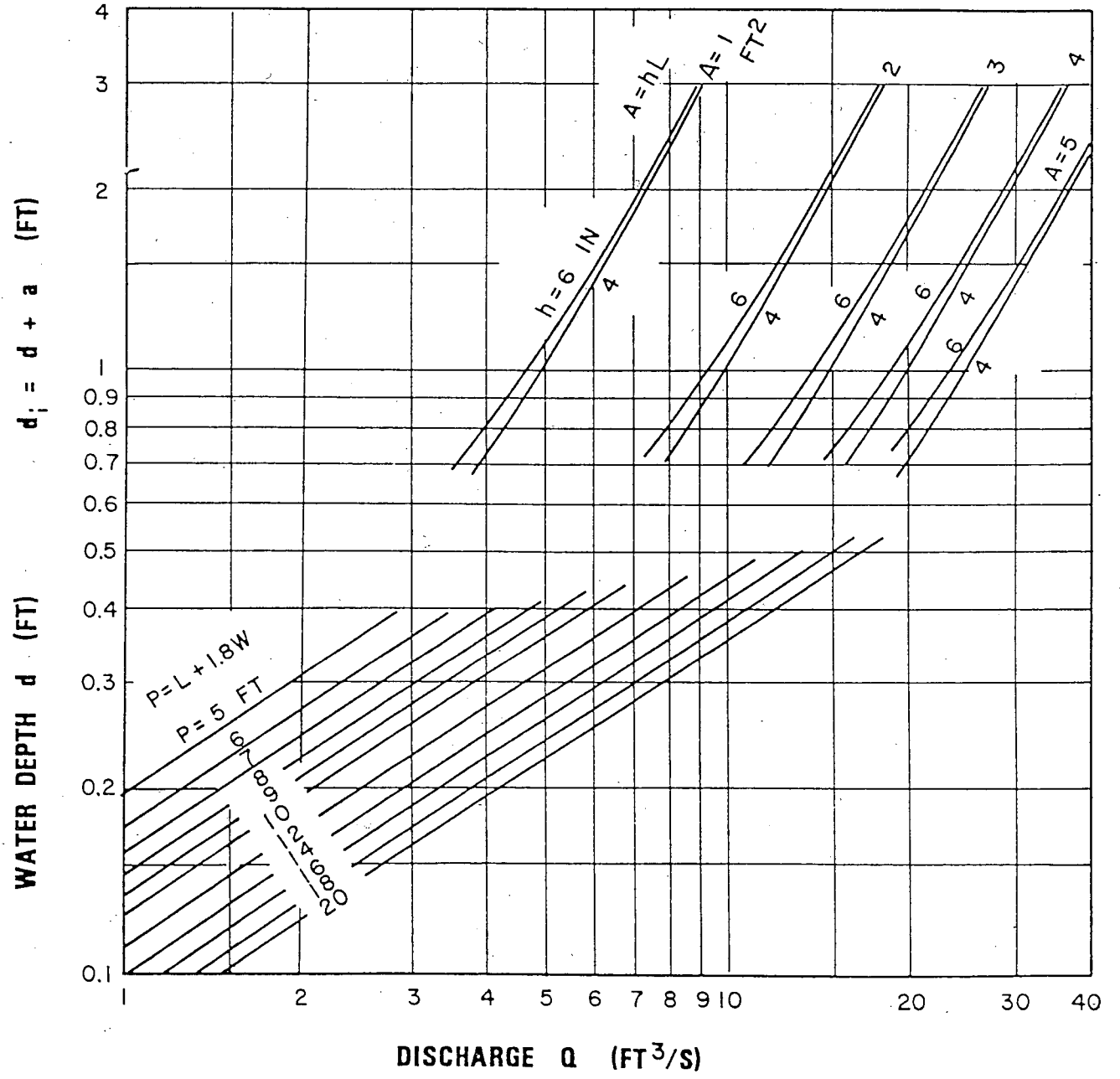
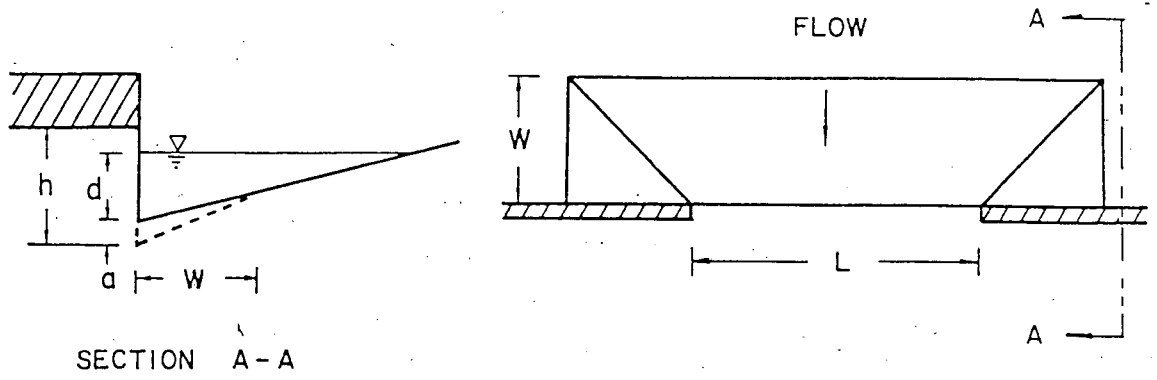

CHART 12. Depressed curb-opening inlet capacity in sump locations.

April 15, 1986

ATTACHMENT A
DRAINAGE CRITERIA MANUAL

RAINFALL INTENSITY TABLE FOR SEDGWICK COUNTY, KANSAS

The following tabulation contains rainfall intensity in inches per hour as derived from ESSA Weather Bureau Technical Paper 40 Modified to NWS Hydro-35, 1977 During First Hour

$(\frac{1}{T_c})$ DURATION IN MINUTES	RETURN PERIODS OF						
	1-YR	2-YR	5-YR	10-YR	25-YR	50-YR	100-YR
5	$i = 4.18$	5.57	6.53	7.41	8.52	9.48	10.32
6	3.99	5.32	6.25	7.09	8.16	9.09	9.89
7	3.81	5.09	5.99	6.81	7.84	8.74	9.50
8	3.66	4.89	5.75	6.55	7.55	8.42	9.15
9	3.52	4.70	5.54	6.31	7.28	8.13	8.83
10	3.39	4.52	5.34	6.09	7.04	7.86	8.54
11	3.27	4.36	5.16	5.89	6.81	7.61	8.27
12	3.18	4.21	4.99	5.71	6.60	7.38	8.02
13	3.05	4.08	4.84	5.53	6.41	7.17	7.79
14	2.96	3.95	4.69	5.37	6.23	6.97	7.57
15	2.87	3.83	4.56	5.22	6.06	6.78	7.37
16	2.78	3.72	4.43	5.08	5.90	6.60	7.18
17	2.71	3.61	4.31	4.95	5.75	6.44	7.00
18	2.63	3.51	4.20	4.83	5.61	6.29	6.84
19	2.56	3.42	4.10	4.71	5.47	6.14	6.68
20	2.50	3.33	4.00	4.60	5.35	6.00	6.53
21	2.44	3.25	3.90	4.50	5.23	5.87	6.39
22	2.38	3.17	3.81	4.40	5.12	5.75	6.26
23	2.32	3.10	3.73	4.31	5.01	5.63	6.13
24	2.27	3.03	3.65	4.22	4.91	5.52	6.01
25	2.22	2.96	3.57	4.13	4.81	5.41	5.90
26	2.20	2.90	3.50	4.05	4.72	5.31	5.79
27	2.16	2.84	3.43	3.98	4.63	5.21	5.69
28	2.14	2.78	3.37	3.90	4.55	5.12	5.59
29	2.11	2.72	3.30	3.83	4.47	5.03	5.49
30	2.08	2.67	3.24	3.76	4.39	4.94	5.40
31	2.05	2.62	3.19	3.70	4.32	4.86	5.32
32	2.02	2.57	3.10	3.63	4.25	4.79	5.22
33	1.99	2.52	3.05	3.57	4.18	4.71	5.14
34	1.96	2.48	3.01	3.51	4.11	4.63	5.07
35	1.93	2.44	2.98	3.46	4.05	4.56	5.00
36	1.91	2.39	2.93	3.41	3.99	4.50	4.93
37	1.89	2.35	2.88	3.36	3.93	4.43	4.86
38	1.87	2.32	2.84	3.31	3.87	4.37	4.79
39	1.85	2.28	2.80	3.26	3.82	4.31	4.73
40	1.83	2.24	2.76	3.22	3.76	4.25	4.66
41	1.81	2.21	2.72	3.17	3.71	4.19	4.60
42	1.79	2.18	2.68	3.13	3.66	4.13	4.54
43	1.77	2.14	2.64	3.09	3.61	4.08	4.49
44	1.75	2.11	2.61	3.05	3.57	4.03	4.43
45	1.73	2.08	2.57	3.01	3.52	3.98	4.38

<u>DURATION IN MINUTES</u>	<u>RETURN PERIODS OF</u>						
	<u>1-YR</u>	<u>2-YR</u>	<u>5-YR</u>	<u>10-YR</u>	<u>25-YR</u>	<u>50-YR</u>	<u>100-YR</u>
46	1.70	2.05	2.54	2.97	3.48	3.93	4.33
47	1.67	2.02	2.50	2.93	3.44	3.88	4.28
48	1.66	2.00	2.47	2.90	3.39	3.84	4.23
49	1.64	1.97	2.44	2.86	3.35	3.79	4.18
50	1.61	1.95	2.41	2.83	3.32	3.75	4.13
51	1.59	1.92	2.38	2.79	3.28	3.71	4.09
52	1.56	1.89	2.35	2.76	3.24	3.67	4.05
53	1.54	1.86	2.33	2.73	3.20	3.63	4.00
54	1.52	1.84	2.30	2.70	3.17	3.59	3.96
55	1.50	1.81	2.27	2.67	3.14	3.55	3.92
56	1.47	1.79	2.25	2.64	3.10	3.51	3.88
57	1.45	1.76	2.22	2.61	3.07	3.48	3.84
58	1.43	1.74	2.20	2.59	3.04	3.44	3.81
59	1.42	1.72	2.18	2.56	3.01	3.41	3.77
60	1.40	1.69	2.15	2.53	2.98	3.37	3.73
61	1.38	1.67	2.13	2.51	2.95	3.34	3.70
62	1.36	1.65	2.11	2.48	2.92	3.31	3.67
63	1.34	1.63	2.09	2.46	2.89	3.28	3.63
64	1.33	1.61	2.07	2.44	2.86	3.25	3.60
65	1.31	1.59	2.05	2.41	2.84	3.22	3.57
66	1.30	1.57	2.03	2.39	2.81	3.19	3.54
67	1.28	1.56	2.01	2.37	2.79	3.16	3.51
68	1.26	1.54	1.99	2.35	2.76	3.13	3.48
69	1.25	1.52	1.97	2.33	2.74	3.10	3.45
70	1.24	1.50	1.95	2.31	2.71	3.08	3.42
71	1.22	1.49	1.93	2.28	2.69	3.05	3.39
72	1.21	1.47	1.92	2.26	2.67	3.02	3.36
73	1.20	1.46	1.90	2.25	2.64	3.00	3.34
74	1.18	1.44	1.88	2.23	2.63	2.98	3.31
75	1.17	1.43	1.86	2.21	2.61	2.95	3.29
76	1.16	1.41	1.85	2.19	2.58	2.93	3.26
77	1.15	1.40	1.83	2.17	2.55	2.90	3.24
78	1.13	1.38	1.82	2.15	2.53	2.88	3.22
79	1.12	1.37	1.80	2.14	2.50	2.86	3.19
80	1.11	1.36	1.79	2.12	2.48	2.84	3.16
81	1.10	1.34	1.77	2.10	2.46	2.82	3.13
82	1.09	1.33	1.76	2.08	2.43	2.79	3.10
83	1.08	1.32	1.74	2.06	2.41	2.76	3.07
84	1.07	1.31	1.73	2.04	2.39	2.74	3.04
85	1.06	1.30	1.72	2.02	2.37	2.71	3.01
86	1.05	1.28	1.70	2.00	2.34	2.69	2.99
87	1.04	1.27	1.69	1.99	2.32	2.66	2.96
88	1.03	1.26	1.68	1.97	2.30	2.64	2.93
89	1.02	1.25	1.68	1.95	2.28	2.62	2.91
90	1.01	1.24	1.66	1.93	2.26	2.59	2.88

ATTACHMENT A CONTINUED

Page 3

<u>DURATION IN MINUTES</u>	<u>RETURN PERIODS OF</u>						
	<u>1-YR</u>	<u>2-YR</u>	<u>5-YR</u>	<u>10-YR</u>	<u>25-YR</u>	<u>50-YR</u>	<u>100-YR</u>
91	1.00	1.23	1.65	1.92	2.24	2.57	2.86
92	1.00	1.22	1.63	1.90	2.22	2.55	2.83
93	0.99	1.21	1.62	1.89	2.20	2.53	2.81
94	0.98	1.20	1.61	1.87	2.19	2.51	2.79
95	0.97	1.19	1.59	1.85	2.17	2.49	2.76
96	0.96	1.18	1.58	1.84	2.15	2.46	2.74
97	0.96	1.17	1.57	1.82	2.13	2.44	2.72
98	0.95	1.16	1.56	1.81	2.12	2.42	2.70
99	0.94	1.15	1.54	1.80	2.10	2.41	2.67
100	0.93	1.14	1.53	1.78	2.08	2.39	2.65
101	0.93	1.13	1.52	1.77	2.07	2.39	2.65
102	0.92	1.13	1.51	1.75	2.05	2.35	2.61
103	0.91	1.12	1.50	1.74	2.04	2.33	2.59
104	0.90	1.11	1.49	1.73	2.02	2.31	2.57
105	0.90	1.10	1.47	1.72	2.01	2.30	2.55
106	0.89	1.09	1.46	1.70	1.99	2.28	2.54
107	0.88	1.09	1.45	1.69	1.98	2.26	2.52
108	0.88	1.08	1.44	1.68	1.96	2.25	2.50
109	0.87	1.07	1.43	1.67	1.95	2.23	2.48
110	0.87	1.06	1.42	1.65	1.93	2.21	2.46
111	0.86	1.06	1.41	1.64	1.92	2.20	2.45
112	0.85	1.05	1.40	1.63	1.91	2.18	2.43
113	0.85	1.04	1.39	1.62	1.89	2.17	2.41
114	0.84	1.03	1.38	1.61	1.88	2.15	2.40
115	0.84	1.03	1.37	1.60	1.87	2.14	2.38
116	0.83	1.02	1.36	1.59	1.86	2.12	2.36
117	0.82	1.01	1.36	1.58	1.84	2.11	2.35
118	0.82	1.01	1.35	1.57	1.83	2.09	2.33
119	0.81	1.00	1.34	1.56	1.82	2.08	2.32
120	0.81	0.99	1.33	1.55	1.81	2.07	2.30

<u>DURATION IN HOURS</u>	<u>RETURN PERIODS OF</u>						
	<u>1-YR</u>	<u>2-YR</u>	<u>5-YR</u>	<u>10-YR</u>	<u>25-YR</u>	<u>50-YR</u>	<u>100-YR</u>
2	0.81	0.99	1.33	1.55	1.81	2.07	2.30
3	0.59	0.72	0.97	1.13	1.32	1.51	1.68
4	0.47	0.58	0.78	0.91	1.06	1.21	1.35
5	0.40	0.49	0.66	0.77	0.89	1.02	1.14
6	0.35	0.42	0.57	0.67	0.78	0.89	0.99
8	0.28	0.34	0.46	0.53	0.62	0.71	0.79
10	0.23	0.29	0.39	0.45	0.52	0.60	0.67
12	0.20	0.25	0.33	0.39	0.45	0.52	0.58
18	0.15	0.18	0.24	0.28	0.33	0.38	0.42
24	0.12	0.15	0.20	0.23	0.27	0.31	0.34

ATTACHMENT D

DRAINAGE CRITERIA

RECOMMENDED RUNOFF COEFFICIENTS FOR RATIONAL METHOD
AND PERCENT IMPERVIOUS FOR UNIT HYDROGRAPH METHOD

Land Use or Surface Characteristics	Percent Impervious	Frequency			
		<u>2</u>	<u>5</u>	<u>10</u>	<u>100</u>
1. Business:					
Downtown Areas	95	0.84	0.85	0.87	0.91
Neighborhood Areas	70	0.68	0.69	0.73	0.80
2. Residential:					
<u>Single Family (Soil Group D)</u>					
1/8 Acre	50	0.57	0.61	0.66	0.79
1/4 Acre	38	0.50	0.54	0.62	0.76
1/3 Acre	30	0.46	0.50	0.59	0.73
1/2 Acre	25	0.42	0.48	0.56	0.72
3/4 Acre	22	0.42	0.46	0.55	0.71
1 Acre	20	0.41	0.45	0.54	0.71
<u>Multi-Family (Soil Group D)</u>					
Multi-Unit (detached)	60	0.62	0.66	0.72	0.82
Multi-Unit (attached)	65	0.64	0.68	0.73	0.83
Apartments	75	0.70	0.73	0.79	0.86
<u>Single Family (Soil Group C)</u>					
1/8 Acre	50	0.55	0.58	0.64	0.73
1/4 Acre	38	0.48	0.51	0.57	0.68
1/3 Acre	30	0.43	0.46	0.53	0.65
1/2 Acre	25	0.40	0.43	0.50	0.63
3/4 Acre	22	0.39	0.42	0.49	0.62
1 Acre	20	0.37	0.40	0.48	0.61
<u>Multi-Family (Soil Group C)</u>					
Multi-Unit (detached)	60	0.60	0.63	0.69	0.77
Multi-Unit (attached)	65	0.63	0.66	0.71	0.79
Apartments	75	0.68	0.72	0.77	0.83
<u>Single-Family (Soil Group B)</u>					
1/8 Acre	50	0.52	0.54	0.59	0.67
1/4 Acre	38	0.44	0.46	0.52	0.61
1/3 Acre	30	0.39	0.41	0.47	0.57
1/2 Acre	25	0.36	0.38	0.44	0.54
3/4 Acre	22	0.34	0.36	0.42	0.52
1 Acre	20	0.33	0.35	0.40	0.51
<u>Multi-Family (Soil Group B)</u>					
Multi-Unit (detached)	60	0.58	0.60	0.65	0.72
Multi-Unit (attached)	65	0.61	0.64	0.68	0.75
Apartments	75	0.67	0.70	0.74	0.80

Land Use or Surface Characteristics	Percent Impervious	Frequency			
		2	5	10	100
<u>Single Family (Soil Group A)</u>					
1/8 Acre	50	0.47	0.50	0.54	0.60
1/4 Acre	38	0.39	0.41	0.45	0.52
1/3 Acre	30	0.33	0.35	0.39	0.47
1/2 Acre	25	0.30	0.31	0.35	0.44
3/4 Acre	22	0.28	0.29	0.33	0.42
1 Acre	20	0.26	0.28	0.32	0.40
<u>Multi-Family (Soil Group A)</u>					
Multi-Unit (detached)	60	0.55	0.57	0.61	0.67
Multi-Unit (attached)	65	0.58	0.60	0.64	0.70
Apartments	75	0.65	0.68	0.72	0.77
3. Industrial:					
Light Areas	70	0.68	0.69	0.73	0.80
Heavy Areas	80	0.74	0.76	0.79	0.84
4. Playgrounds:					
	15	0.33	0.35	0.42	0.55
5. Schools:					
	40	0.49	0.51	0.56	0.66
6. Railroad Yard Areas:					
	30	0.43	0.45	0.50	0.62
7. Undeveloped Urban Areas: Offsite Flow Analysis (when land use not defined)					
	45	0.52	0.54	0.59	0.68
8. Streets:					
Paved	99	0.87	0.88	0.90	0.93
Gravel	00	0.24	0.26	0.33	0.48
9. Drive, Parking Lots and Walks:					
	96	0.87	0.87	0.88	0.89
10. Roofs:					
	90	0.80	0.85	0.90	0.93
11. Urban Lawn Areas (See Note No. 1 below):					
<u>Soil Group A</u>					
Slope less than 1%	00	0.08	0.09	0.13	0.23
Slope 1% to 4%	00	0.12	0.13	0.17	0.27
Slope more than 4%	00	0.16	0.17	0.21	0.31
<u>Soil Group B</u>					
Slope less than 1%	00	0.16	0.18	0.24	0.37
Slope 1% to 4%	00	0.20	0.22	0.28	0.41
Slope more than 4%	00	0.24	0.26	0.32	0.45
<u>Soil Group C</u>					
Slope less than 1%	00	0.24	0.27	0.35	0.51
Slope 1% to 4%	00	0.26	0.29	0.37	0.53
Slope more than 4%	00	0.28	0.31	0.39	0.55

Land Use or Surface Characteristics	Percent Impervious	Frequency			
		2	5	10	100
<u>Soil Group D</u>					
Slope less than 1%	00	0.28	0.33	0.43	0.63
Slope 1% to 4%	00	0.30	0.35	0.45	0.65
Slope more than 4%	00	0.32	0.37	0.47	0.67

Note No. 1: Coefficients shown in the above table are for pervious open space areas with thick turf which includes pervious areas in parks and cemeteries. Coefficients shown above must be increased 0.02 for use with agricultural pasture areas. Coefficients shown above must be reduced by 0.04 for use with agricultural cultivated areas. Group A soils are well-drained, coarse textured sands with high infiltration rates. Group B soils are moderately well-drained, moderately coarse textured soils with moderate infiltration rates. Group C soils are moderately poor-drained, moderately fine textured soils with slow infiltration rates. Group D soils are poor-drained, fine textured soils with very slow infiltration rates.

GENERAL NOTE: These Rational Formula Coefficients may not be valid for basins 320 acres or larger.

ATTACHMENT E

DRAINAGE CRITERIA

AVERAGE OVERLAND FLOW VELOCITY FOR USE WITH URBANIZED AREAS

Surface Type	VELOCITY IN FEET/SECOND FOR SLOPES IN PERCENT SHOWN																				
	0.1	0.2	0.3	0.4	0.5	0.6	0.7	0.8	0.9	1.0	2.0	3.0	4.0	5.0	6.0	7.0	8.0	9.0	10.0	20.0	
Forest with Heavy Ground Litter or Meadow	0.03	0.04	0.06	0.07	0.08	0.09	0.10	0.11	0.12	0.13	0.16	0.21	0.28	0.33	0.39	0.46	0.53	0.60	0.72	1.10	
Low or Minimum Tillage Cultivation	0.06	0.08	0.10	0.12	0.13	0.14	0.16	0.17	0.18	0.19	0.29	0.40	0.51	0.66	0.78	0.91	1.05	1.20	1.44	2.10	
Short Grass Pasture & Lawns	0.09	0.13	0.15	0.18	0.20	0.21	0.23	0.25	0.26	0.28	0.45	0.60	0.77	0.96	1.17	1.33	1.50	1.68	1.98	3.20	
Most Bare Ground	0.16	0.22	0.28	0.31	0.35	0.38	0.41	0.44	0.46	0.49	0.70	0.85	1.05	1.26	1.50	1.75	2.03	2.32	2.79	4.40	
Grassed Waterway	0.35	0.48	0.58	0.67	0.77	0.84	0.91	0.98	1.05	1.12	1.54	1.82	2.10	2.38	2.78	3.20	3.66	4.14	4.56	7.00	
Grassed Areas (Sheet Flow) or Grassed Gutter Flow	0.44	0.62	0.77	0.91	1.05	1.12	1.19	1.26	1.33	1.40	2.00	2.55	3.20	3.83	4.41	5.04	5.70	6.00	6.20	9.00	

EXHIBIT NO. 1

SOIL LEGEND

<u>SYMBOL</u>	<u>HYDROLOGIC GROUP</u>	<u>NAME</u>
Aa	B	Albion-Shellabarger sandy loams, 1 to 4 percent slopes
Ab	B	Albion and Shellabarger sandy loams, 7 to 15 percent slopes
Ba	C	Blanket silt loam, 0 to 1 percent slopes
Bb	C	Blanket silt loam, 1 to 3 percent slopes
Ca	B	Canadian fine sandy loam
Cb	B	Canadian-Waldeck fine sandy loams
Cc	D	Carwile fine sandy loam
Cd	B	Clark-Ost clay loams, 1 to 4 percent slopes
Ce	C	Clime silty clay, 3 to 6 percent slopes
Ea	B	Elandco silt loam
Eb	B	Elandco silt loam, occasionally flooded
Ec	B	Elandco silt loam, frequently flooded
Fa	B	Farnum loam, 0 to 1 percent slopes
Fb	B	Farnum loam, 1 to 3 percent slopes
Fc	B	Farnum loam, sandy substratum, 0 to 1 percent slopes
Ga	D	Goessel silty clay, 0 to 1 percent slopes
Gb	D	Goessel silty clay, 1 to 2 percent slopes
Ia	D	Irwin silty clay loam, 1 to 3 percent slopes
Ib	D	Irwin silty clay loam, 3 to 6 percent slopes
Ic	D	Irwin silty clay loam, 2 to 6 percent slopes, eroded
La	C	Lesho loam
Lb	A	Lincoln soils
Ma	B	Milan loam, 1 to 3 percent slopes
Mb	B	Milan form, 3 to 6 percent slopes
Mc	B	Milan clay loam, 2 to 6 percent slopes, eroded
Na	B	Naron fine sandy loam
Oc	D	Owens clay loam, 1 to 3 percent slopes
Od	D	Owens-Rock outcrop complex, 3 to 10 percent slopes
Pa		Pits
Pb	D	Plevna fine sandy loam
Pc	A	Pratt loamy fine sand, undulating
Pd	A	Pratt-Tivoli complex, rolling
Ra	D	Renfrow silty clay loam, 1 to 3 percent slopes
Rb	D	Renfrow silty clay loam, 3 to 6 percent slopes
Rc	D	Renfrow-Owens clay loams, 1 to 4 percent slopes
Rd	D	Rosehill silty clay, 1 to 3 percent slopes
Sa	B	Shellabarger sandy loam, 1 to 3 percent slopes
Sb	B	Shellabarger sandy loam, 3 to 6 percent slopes
Sc	B	Shellabarger sandy loam, 3 to 6 percent slopes, eroded
Ta	D	Tabler silty clay loam
Tb	D	Tabler-Drummond complex
Ua	B	Urban land-Canadian complex
Ub	B	Urban land-Elandco complex
Uc	B	Urban land-Farnum complex, 0 to 3 percent slopes
Ud	D	Urban land-Irwin complex, 1 to 3 percent slopes
Ue	D	Urban land-Tabler complex
Va	B	Vanoss silt loam, 0 to 1 percent slopes
Vb	B	Vanoss silt loam, 1 to 3 percent slopes
Vc	B	Vanoss silt loam, 3 to 6 percent slopes
Vd	B	Vanoss silt loam, 3 to 6 percent slopes, eroded
Ve	D	Vernon sandy loam, 1 to 3 percent slopes
Vf	D	Vernon sandy loam, 3 to 6 percent slopes

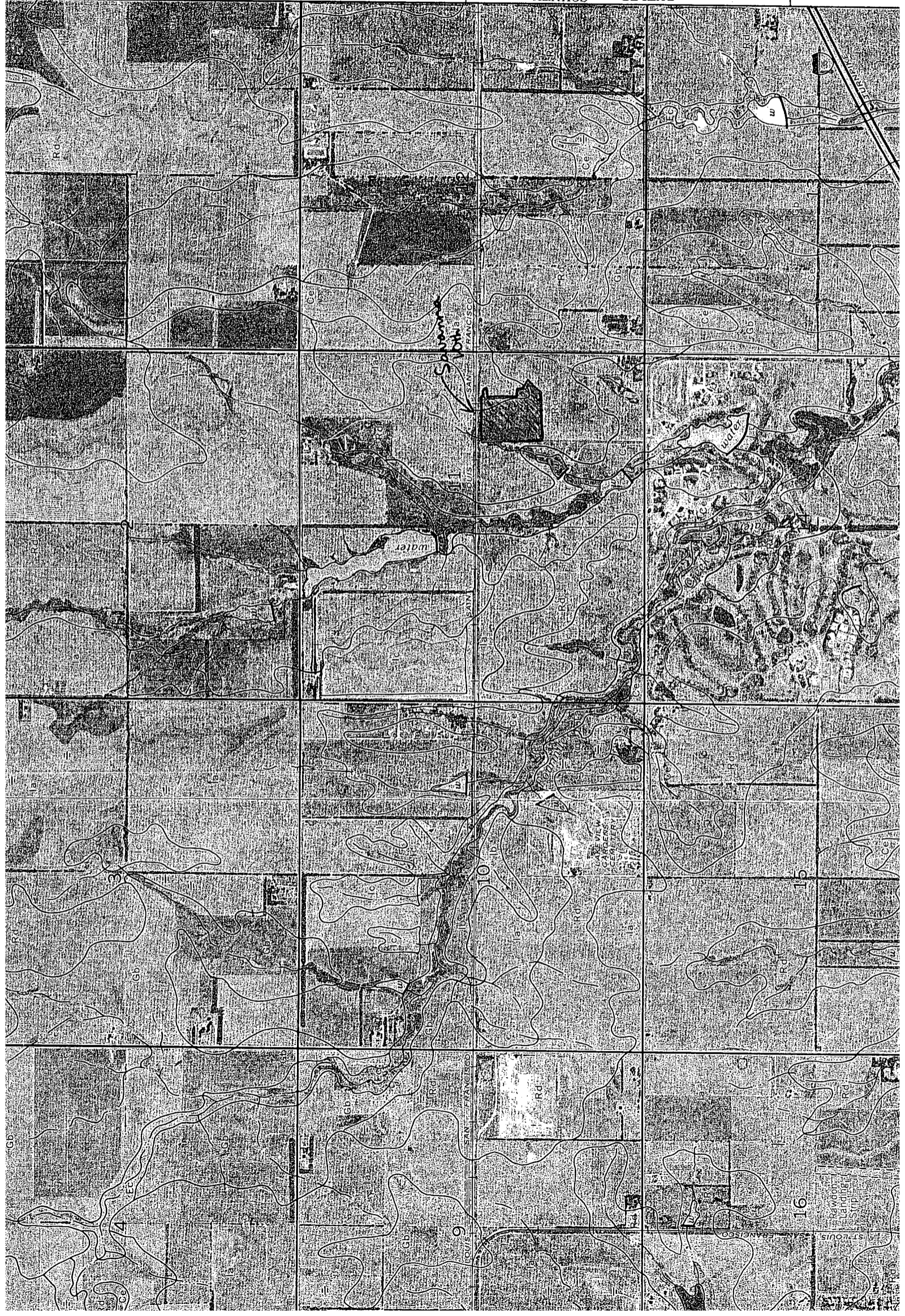

SAVANNA AT CASTLE ROCK RANCH 10TH ADDITION

TO SEDGWICK COUNTY, KANSAS

FOUR-CORNER PLAN

N.E. CORNER S.E. 1/4
SEC. 11, T27S, R2E
OF THE 6TH P.M.

ST. LOUIS WICHITA AND WESTERN RAILROAD CO.
(NOW BURLINGTON NORTHERN)

Drainage Channel
See Drainage Plan For Details

OWNER: HAL W. MCCOY
UNPLATTED
ZONED: SF-20 "SINGLE FAMILY"

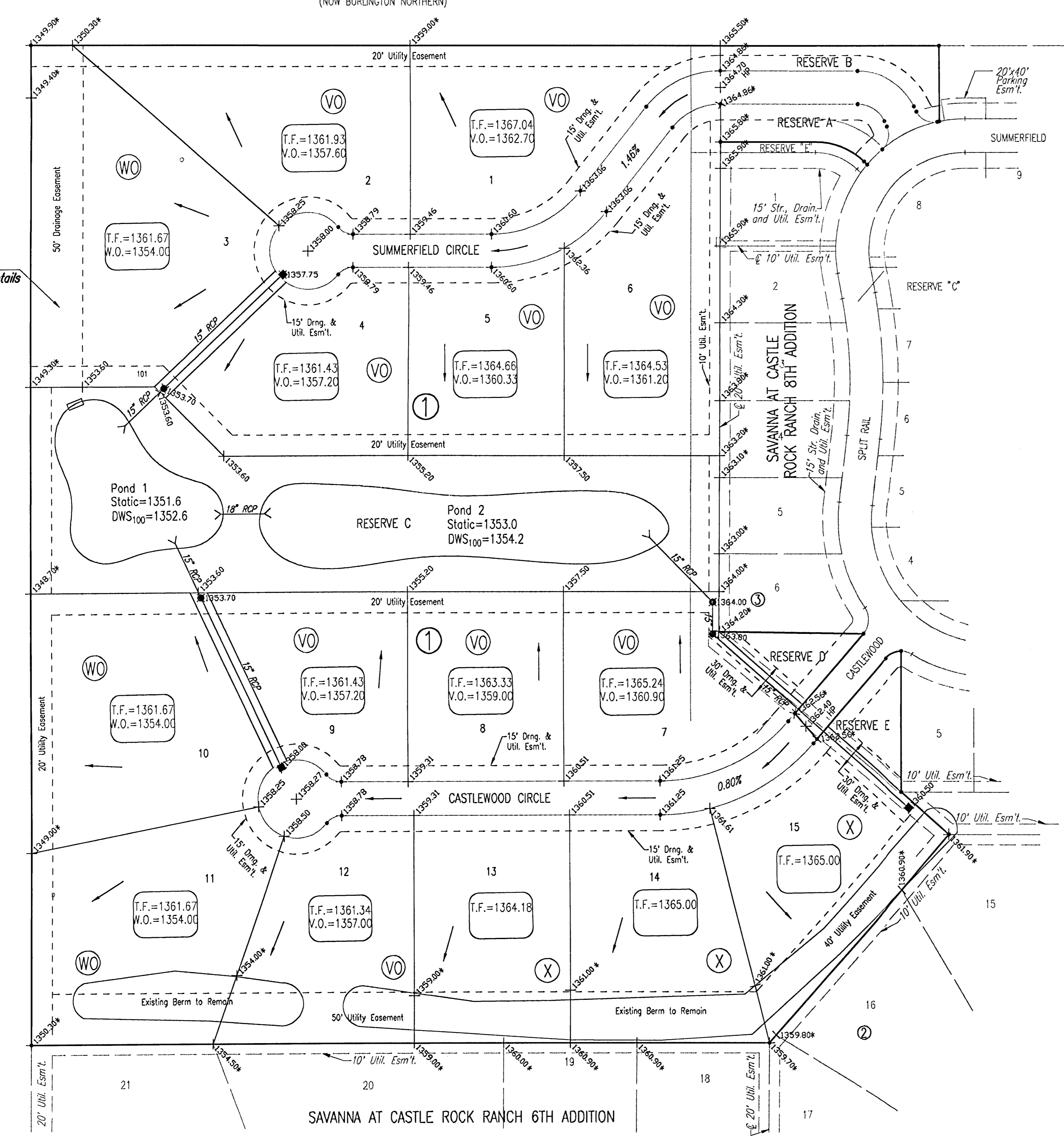

SCALE: 1" = 60'

• = 1/2" REBAR W/PEC CAP UNLESS OTHERWISE NOTED

LEGEND

- STORM WATER FLOW
- ⊙ (VO) VIEW-OUT BASEMENT
- ⊙ (WO) WALK-OUT BASEMENT
- ⊙ (X) STANDARD BASEMENT
- +1355.00 SPOT ELEVATION (PROPOSED)
- +1355.00 HIGH POINT ELEVATION (PROPOSED)
- +1355.00 MATCH EXISTING ELEVATION
- STORM SEWER AND INLET
- STORM SEWER AND MANHOLE

- BENCHMARKS:**
- BW/60: (DATUM BENCHMARK) CHISELED "*" ON TOP OF STEEL CORNER POST TO HORSE CORRAL, 17' NORTH AND 13' WEST OF NW CORNER OF LOT 1, BLOCK 2, SAVANNA @ CASTLE ROCK RANCH 6TH ADDITION @ WEST END OF CASTLEWOOD STREET. ELEV. = 1353.36 N.G.V.D.
 - BW/4: 600 STEP NAILS IN WEST FACE 36" COTTONWOOD, 300'± SOUTH OF RAILROAD TRACKS, 50' EAST OF WEST PROPERTY LINE OF SAVANNA PROPERTY. ELEV. = 1351.64 N.G.V.D.
 - BW/6: CHISELED "X" ON NORTH RIM SS MANHOLE NEAR SW CORNER LOT 1, BLOCK 3, SAVANNA @ CASTLE ROCK RANCH, 8TH ADDITION. ELEV. = 1366.24 N.G.V.D.
 - BW/7: CHISELED "X" ON NORTH RIM SS MANHOLE NEAR SW CORNER LOT 6, BLOCK 3, SAVANNA @ CASTLE ROCK RANCH 8TH ADDITION. ELEV. = 1365.61 N.G.V.D.

MINIMUM OPENINGS	ELEVATION (N.G.V.D.)
BLOCK 1	
LOTS 3 & 10	1354.0
LOTS 4 through 9	1357.2

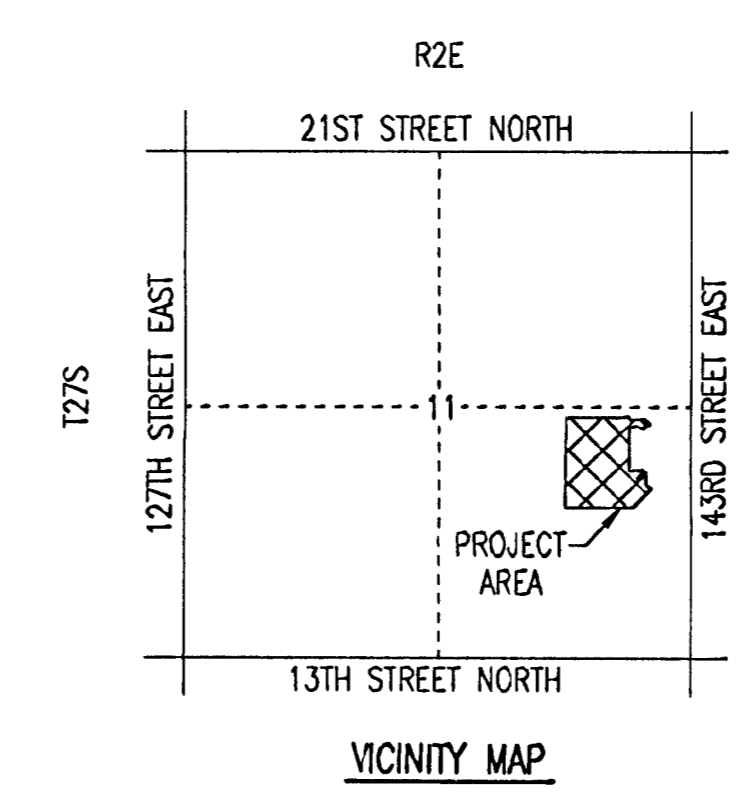

DSNR: BLB OPER: BLB SCALE: 1"=60.00
 CA: 2003\03\342\DD 03\342\DWG\FCORNER 03-12-2004 08:17:57 am