

DRAINAGE PLAN
SOUTHERN RIDGE
ADDITION
TO
WICHITA, SEDGWICK COUNTY, KANSAS

DRAINAGE PLAN
SOUTHERN RIDGE
ADDITION
TO
WICHITA, SEDGWICK COUNTY, KANSAS

DRAINAGE PLAN
SOUTHERN RIDGE
ADDITION
TO
WICHITA, SEDGWICK COUNTY, KANSAS

Prepared By

 **BAUGHMAN COMPANY, P.A.**
ENGINEERING, SURVEYING & PLANNING
316/262-7271 FAX 316/262-0149 WICHITA, KANSAS 67211

October 15, 2002

INTRODUCTION

This report provides information and supporting documentation to support the "Drainage Plan" for the property located in the Southwest Quarter of Section 5, T-29-S, R-2-E in Sedgwick County, Kansas.

The "Drainage Plan" being submitted herein is intended to serve as a guide for the design of detention facilities, parking lots, and storm water sewer improvements to the proposed developments. Modifications to structures, pipes, etc. may be made as necessary during the final design in order to obtain the most economical design and construction possible.

SUMMARY

Hydrologic and hydraulic calculations have been performed on those aspects of the drainage that will directly affect the area submitted as "Southern Ridge Addition". This development will consist of underground stormwater sewer systems as well as the construction of a detention pond. Existing conditions at the dbl. 9'X4' RCBC located at Maize Rd. generates a 100-yr peak discharge of 750 cfs. The proposed drainage improvements will reduce the calculated peak flowrate to 480 cfs. Calculations show that the RCBC has a capacity of 650 cfs, and therefore has sufficient capacity to pass the proposed 100-yr peak discharge.

The existing right-of-way ditch section along the south side of Pawnee Ave. will require re-grading to accommodate the proposed 12'X4' RCBC at Lark. The proposed channel section will be a trapezoidal section with 3:1 side slopes and a bottom width of 15 ft. Based on an assumed bed slope of 0.5%, the capacity of the section is 730 cfs, sufficient to carry the off-site drainage from the west totalling 310 cfs.

Typical Channel Section
Worksheet for Trapezoidal Channel

Project Description	
Project File	untitled.fm2
Worksheet	Pawnee Ave.
Flow Element	Trapezoidal Channel
Method	Manning's Formula
Solve For	Channel Depth

Input Data	
Mannings Coefficient	0.030
Channel Slope	0.005000 ft/ft
Left Side Slope	3.000000 H : V
Right Side Slope	3.000000 H : V
Bottom Width	15.00 ft
Discharge	340.00 cfs

Results	
Depth	2.70 ft
Flow Area	62.33 ft ²
Wetted Perimeter	32.07 ft
Top Width	31.19 ft
Critical Depth	2.16 ft
Critical Slope	0.011444 ft/ft
Velocity	5.45 ft/s
Velocity Head	0.46 ft
Specific Energy	3.16 ft
Froude Number	0.68
Flow is subcritical.	

CURRENT DATE: 09-20-2002
 CURRENT TIME: 15:41:24

FILE DATE: 09-20-2002
 FILE NAME: PAWNEE

 ***** FHWA CULVERT ANALYSIS *****
 ***** HY-8, VERSION 4.1 *****

C U L V #	SITE DATA			CULVERT SHAPE, MATERIAL, INLET				
	INLET ELEV. (FT)	OUTLET ELEV. (FT)	CULVERT LENGTH (FT)	BARRELS SHAPE MATERIAL	SPAN (FT)	RISE (FT)	MANNING n	INLET TYPE
1	100.00	99.80	100.00	1 RCB	12.00	4.00	.013	CONVENTIONAL
2								
3								
4								
5								
6								

 SUMMARY OF CULVERT FLOWS (CFS) FILE: PAWNEE DATE: 09-20-2002

ELEV (FT)	TOTAL	1	2	3	4	5	6	ROADWAY	ITR
100.00	0	0	0	0	0	0	0	0	1
101.22	45	45	0	0	0	0	0	0	1
101.92	90	90	0	0	0	0	0	0	1
102.52	135	135	0	0	0	0	0	0	1
103.05	180	180	0	0	0	0	0	0	1
103.54	225	225	0	0	0	0	0	0	1
104.00	270	270	0	0	0	0	0	0	1
104.43	315	315	0	0	0	0	0	0	1
104.70	340	340	0	0	0	0	0	0	1
105.27	405	384	0	0	0	0	0	21	5
105.45	450	403	0	0	0	0	0	46	3
105.00	366	366	0	0	0	0	0	OVERTOPPING	

 SUMMARY OF ITERATIVE SOLUTION ERRORS FILE: PAWNEE DATE: 09-20-2002

HEAD ELEV (FT)	HEAD ERROR (FT)	TOTAL FLOW (CFS)	FLOW ERROR (CFS)	% FLOW ERROR
100.00	0.00	0	0	0.00
101.22	0.00	45	0	0.00
101.92	0.00	90	0	0.00
102.52	0.00	135	0	0.00
103.05	0.00	180	0	0.00
103.54	0.00	225	0	0.00
104.00	0.00	270	0	0.00
104.43	0.00	315	0	0.00
104.70	0.00	340	0	0.00
105.27	-0.00	405	0	0.06
105.45	-0.00	450	1	0.21

CURRENT DATE: 09-20-2002
 CURRENT TIME: 15:41:24

FILE DATE: 09-20-2002
 FILE NAME: PAWNEE

PERFORMANCE CURVE FOR CULVERT # 1 - 1 (12 BY 4) RCB

DIS- CHARGE FLOW (cfs)	HEAD- WATER ELEV. (ft)	INLET CONTROL DEPTH (ft)	OUTLET CONTROL DEPTH (ft)	FLOW TYPE <F4>	NORMAL DEPTH (ft)	CRITICAL DEPTH (ft)	OUTLET VEL. (fps)	DEPTH (ft)	TAILWATER VEL. (fps)	DEPTH (ft)
0	100.00	0.00	0.00	0-NF	0.00	0.00	0.00	0.00	0.00	0.00
45	101.22	1.13	1.22	3-M1t	0.87	0.76	4.26	0.88	2.90	0.88
90	101.92	1.80	1.92	3-M2t	1.36	1.21	5.75	1.31	3.65	1.31
135	102.52	2.38	2.52	3-M2t	1.77	1.58	6.87	1.64	4.14	1.64
180	103.05	2.92	3.05	3-M2t	2.15	1.92	7.82	1.92	4.52	1.92
225	103.54	3.43	3.54	2-M2c	2.50	2.22	8.43	2.22	4.84	2.16
270	104.00	3.92	4.00	2-M2c	2.84	2.51	8.96	2.51	5.10	2.39
315	104.43	4.42	4.43	2-M2c	3.16	2.78	9.43	2.78	5.34	2.59
340	104.70	4.70	4.66	2-M2c	3.33	2.93	9.68	2.93	5.46	2.70
384	105.28	5.21	5.28	6-FFn	4.00	3.17	8.00	4.00	5.74	2.96
403	105.45	5.45	5.43	6-FFn	4.00	3.28	8.41	4.00	5.91	3.12

El. inlet face invert 100.00 ft El. outlet invert 99.80 ft
 El. inlet throat invert 0.00 ft El. inlet crest 0.00 ft

***** SITE DATA ***** CULVERT INVERT *****

INLET STATION (FT) 0.00
 INLET ELEVATION (FT) 100.00
 OUTLET STATION (FT) 100.00
 OUTLET ELEVATION (FT) 99.80
 NUMBER OF BARRELS 1
 SLOPE (V-FT/H-FT) 0.0020
 CULVERT LENGTH ALONG SLOPE (FT) 100.00

***** CULVERT DATA SUMMARY *****

BARREL SHAPE BOX
 BARREL SPAN 12.00 FT
 BARREL RISE 4.00 FT
 BARREL MATERIAL CONCRETE
 BARREL MANNING'S N 0.013
 INLET TYPE CONVENTIONAL
 INLET EDGE AND WALL 1:1 BEVEL (45 DEG. FLARE)
 INLET DEPRESSION NONE

CURRENT DATE: 09-20-2002
CURRENT TIME: 15:41:24

FILE DATE: 09-20-2002
FILE NAME: PAWNEE

***** TAILWATER *****

***** REGULAR CHANNEL CROSS SECTION *****
BOTTOM WIDTH (FT) 15.00
SIDE SLOPE H/V (X:1) 3.0
CHANNEL SLOPE V/H (FT/FT) 0.005
MANNING'S N (.01-0.1) 0.030
CHANNEL INVERT ELEVATION (FT) 99.80
CULVERT NO.1 OUTLET INVERT ELEVATION 99.80 FT

***** UNIFORM FLOW RATING CURVE FOR DOWNSTREAM CHANNEL

FLOW (CFS)	W.S.E. (FT)	FROUDE NUMBER	DEPTH (FT)	VEL. (FPS)	SHEAR (PSF)
0.00	99.80	0.000	0.00	0.00	0.00
45.00	100.68	0.545	0.88	2.90	0.27
90.00	101.11	0.562	1.31	3.65	0.41
135.00	101.44	0.570	1.64	4.14	0.51
180.00	101.72	0.576	1.92	4.52	0.60
225.00	101.96	0.579	2.16	4.84	0.68
270.00	102.19	0.582	2.39	5.10	0.74
315.00	102.39	0.584	2.59	5.34	0.81
340.00	102.50	0.585	2.70	5.46	0.84
405.00	102.76	0.588	2.96	5.74	0.92
450.00	102.92	0.589	3.12	5.91	0.97

***** ROADWAY OVERTOPPING DATA *****

ROADWAY SURFACE	PAVED
EMBANKMENT TOP WIDTH (FT)	2.60
CREST LENGTH (FT)	50.00
OVERTOPPING CREST ELEVATION (FT)	105.00

MASTER DESIGN STORM SUMMARY

Default Network Design Storm File, ID WICHITA.RNQ COW25100

Return Event	Total Depth in	Rainfall Type	RNF File	RNF ID	
Pre..2	3.6000	Synthetic Curve	SCSTYPES	TypeII	24hr
Pre..5	4.5600	Synthetic Curve	SCSTYPES	TypeII	24hr
Pre100	7.6800	Synthetic Curve	SCSTYPES	TypeII	24hr

MASTER NETWORK SUMMARY
 SCS Unit Hydrograph Method

(*Node=Outfall; +Node=Diversion;)
 (Trun= HYG Truncation: Blank=None; L=Left; R=Rt; LR=Left&Rt)

Storage Node ID	Type	Return Event	HYG Vol ac-ft	Trun	Qpeak hrs	Qpeak cfs	Max WSEL ft	Max Pond ac-ft
BAALMANN	JCT	2	29.661		12.6600	155.21		
BAALMANN	JCT	5	42.102		12.6600	221.44		
BAALMANN	JCT	100	84.896		12.6600	442.74		
*MAIZERD	JCT	2	72.470		12.8600	260.91		
*MAIZERD	JCT	5	103.127		12.8400	373.56		
*MAIZERD	JCT	100	208.813		12.7000	754.72		
NORTH	AREA	2	6.379		12.2400	53.34		
NORTH	AREA	5	8.921		12.2400	74.62		
NORTH	AREA	100	17.563		12.2400	144.63		
SITE	AREA	2	29.661		12.6600	155.21		
SITE	AREA	5	42.102		12.6600	221.44		
SITE	AREA	100	84.896		12.6600	442.74		
WEST	AREA	2	36.430		13.3400	114.72		
WEST	AREA	5	52.104		13.3400	165.97		
WEST	AREA	100	106.354		13.3400	339.57		
WOODBBOX	JCT	2	42.809		13.3400	124.00		
WOODBBOX	JCT	5	61.025		13.3400	178.47		
WOODBBOX	JCT	100	123.917		13.3400	362.40		

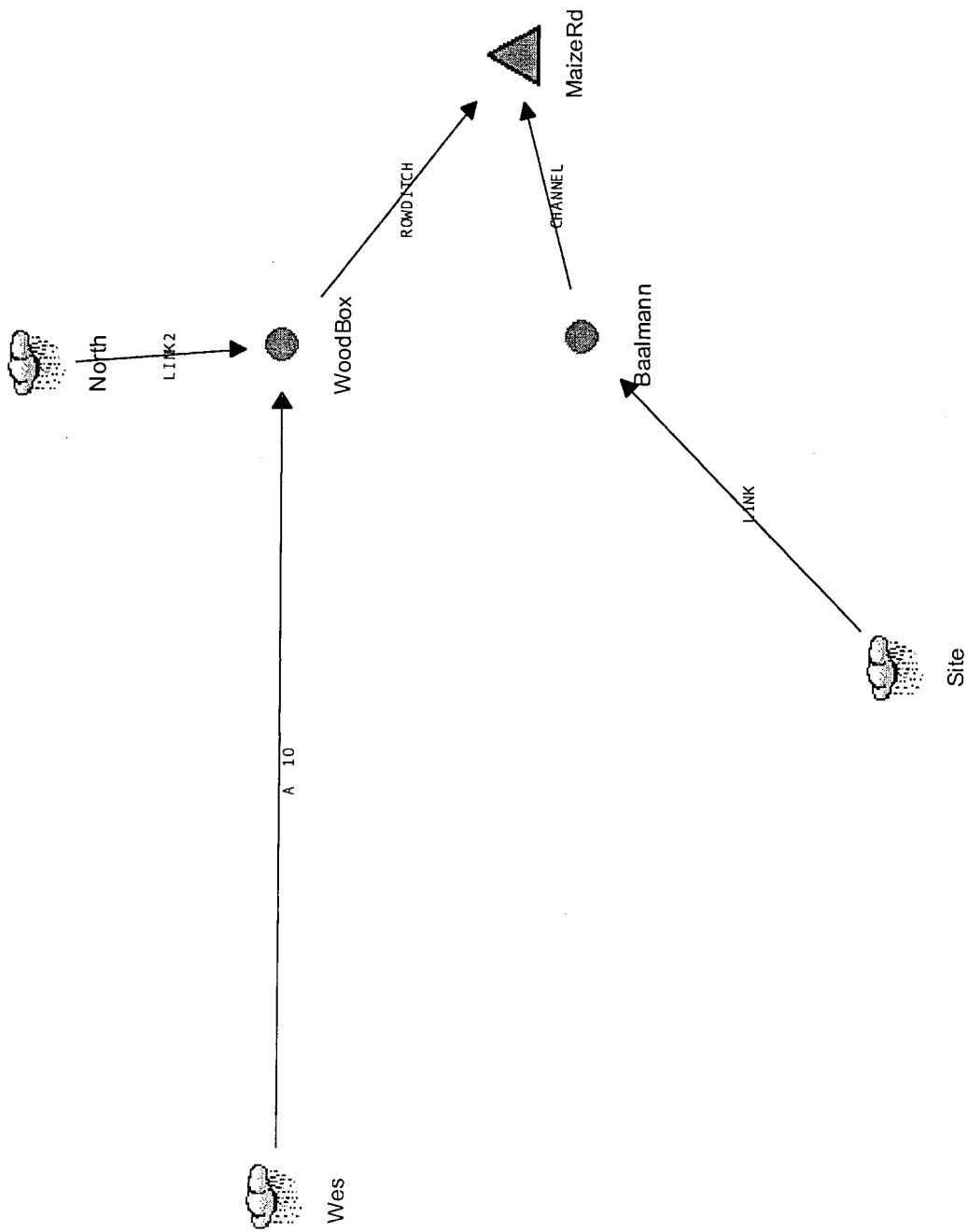

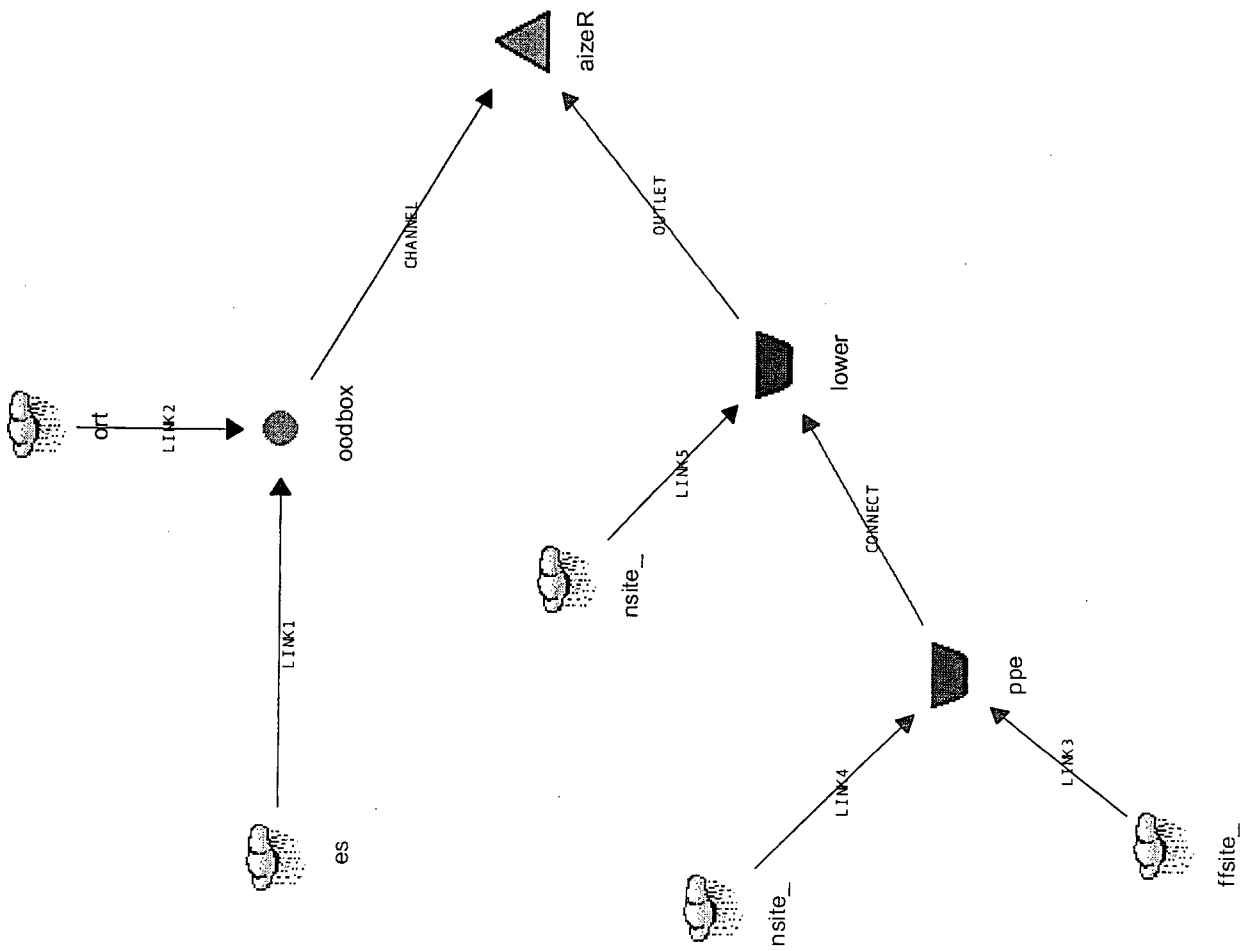

MASTER DESIGN STORM SUMMARY

Default Network Design Storm File, ID WICHITA.RNQ COW25100

Return Event	Total Depth in	Rainfall Type	RNF File	RNF ID	
Dev..2	3.6000	Synthetic Curve	SCSTYPES	TypeII	24hr
Dev..5	4.5600	Synthetic Curve	SCSTYPES	TypeII	24hr
Dev100	7.6800	Synthetic Curve	SCSTYPES	TypeII	24hr

ICPM CALCULATION TOLERANCES

Target Convergence= .000 cfs +/-
 Max. Iterations = 35 loops
 ICPM Time Step = .0500 hrs
 Output Time Step = .0500 hrs
 ICPM Ending Time = 35.0000 hrs

MASTER NETWORK SUMMARY
 SCS Unit Hydrograph Method

(*Node=Outfall; +Node=Diversion;)
 (Trun= HYG Truncation: Blank=None; L=Left; R=Rt; LR=Left&Rt)

Storage Node ID	Return Type	Event	HYG Vol ac-ft	Trun	Qpeak hrs	Qpeak cfs	Max WSEL ft	Max Pond ac-ft
LOWER	POND	2	28.574		12.0000	224.03		
LOWER	POND	5	40.212		12.0000	318.58		
LOWER	POND	100	79.942		12.0000	636.87		
LOWER	OUT POND	2	27.564		13.7500	39.71	134.17	9.302
LOWER	OUT POND	5	39.049		13.5500	63.43	134.96	12.963
LOWER	OUT POND	100	78.454		12.6000	134.38	137.29	24.784
*MAIZERD	E-Q	2	68.922		13.4000	157.51	132.29	
*MAIZERD	E-Q	5	98.385		13.3500	235.24	133.00	
*MAIZERD	E-Q	100	200.204		13.3500	481.01	134.87	
NORTH	AREA	2	6.380		12.2500	53.33		
NORTH	AREA	5	8.922		12.2500	74.56		
NORTH	AREA	100	17.564		12.2500	144.37		

MASTER NETWORK SUMMARY
 SCS Unit Hydrograph Method

(*Node=Outfall; +Node=Diversion;)
 (Trun= HYG Truncation: Blank=None; L=Left; R=Rt; LR=Left&Rt)

Storage Node ID	Type	Return Event	HYG Vol ac-ft	Trun	Qpeak hrs	Qpeak cfs	Max WSEL ft	Max Pond ac-ft
OFFSITE_S	AREA	2	4.534		12.6500	23.63		
OFFSITE_S	AREA	5	6.484		12.6500	34.07		
OFFSITE_S	AREA	100	13.236		12.6500	69.21		
ONSITE_N	AREA	2	13.493		12.0000	210.14		
ONSITE_N	AREA	5	18.870		12.0000	291.33		
ONSITE_N	AREA	100	37.149		12.0000	556.34		
ONSITE_S	AREA	2	10.941		12.0000	170.39		
ONSITE_S	AREA	5	15.300		12.0000	236.21		
ONSITE_S	AREA	100	30.121		12.0000	451.08		
UPPER	POND	2	15.474		12.0000	177.05		
UPPER	POND	5	21.784		12.0000	246.51		
UPPER	POND	100	43.357		12.0000	474.26		
UPPER	OUT POND	2	15.080		12.9000	35.59	135.12	5.946
UPPER	OUT POND	5	21.342		12.6500	56.78	135.78	7.968
UPPER	OUT POND	100	42.793		12.2000	142.66	137.77	14.606
WEST	AREA	2	34.979		13.3500	109.55		
WEST	AREA	5	50.415		13.3500	160.11		
WEST	AREA	100	104.186		13.3500	332.69		
WOODBBOX	JCT	2	41.358		13.3500	118.73		
WOODBBOX	JCT	5	59.336		13.3500	172.46		
WOODBBOX	JCT	100	121.750		13.3500	355.26		

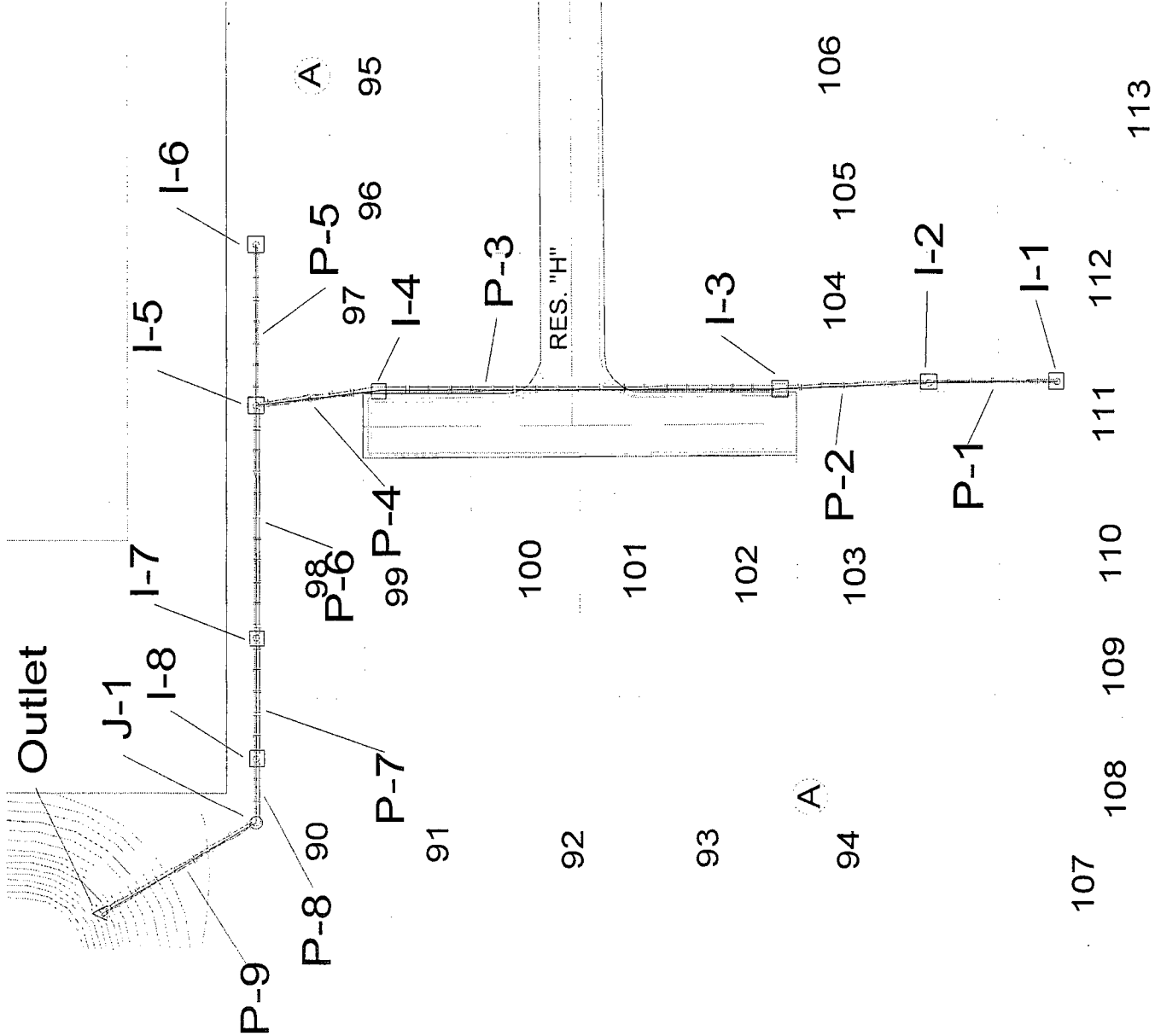

Node Report

Node	Weighted Roughness Coefficient	Total CA (acres)	Inlet TC (min)	System Flow Time (min)	System Intensity (in/hr)	Total Watershed (CIA) (cfs)	Additional Flow (cfs)	Known Flow (cfs)	Discharge (cfs)	Ground Elevation (ft)	HGL In (ft)	HGL Out (ft)	Inlet Intensity (in/hr)	Inlet Area (acres)
I-6	0.00	0.00	0.00	0.00	0.00	0.00	2.60	0.00	2.60	138.70	138.70	138.70	0.00	0.00
I-1	0.00	0.00	0.00	0.00	0.00	0.00	4.30	0.00	4.30	141.00	141.00	141.00	0.00	0.00
I-2	0.00	0.00	0.00	0.31	0.00	0.00	3.90	0.00	8.20	140.30	140.71	140.71	0.00	0.00
I-3	0.00	0.00	0.00	0.58	0.00	0.00	1.20	0.00	9.40	140.80	140.71	140.49	0.00	0.00
I-4	0.00	0.00	0.00	1.22	0.00	0.00	1.20	0.00	10.60	140.80	138.86	138.77	0.00	0.00
I-5	0.00	0.00	0.00	1.53	0.00	0.00	0.00	0.00	13.20	139.50	138.63	138.49	0.00	0.00
I-7	0.00	0.00	0.00	2.00	0.00	0.00	3.50	0.00	16.70	138.30	138.10	138.01	0.00	0.00
I-8	0.00	0.00	0.00	2.29	0.00	0.00	4.30	0.00	21.00	138.60	137.91	137.76	0.00	0.00
J-1	N/A	0.00	N/A	2.42	0.00	0.00	N/A	N/A	21.00	138.40	137.68	137.54	N/A	N/A
Outlet	N/A	0.00	N/A	2.77	0.00	0.00	N/A	N/A	N/A	137.50	137.30	137.30	N/A	N/A

Pipe Report

Upstream Node	Downstream Node	Constructed Slope (ft/ft)	Section Size	Length (ft)	Upstream Invert Elevation (ft)	Downstream Invert Elevation (ft)	Upstream Ground Elevation (ft)	Downstream Ground Elevation (ft)	Upstream HGL (ft)	Downstream HGL (ft)	Upstream Cover (ft)	Downstream Cover (ft)	Discharge (cfs)	Roughness	Section Material
I-6	I-5	0.003704	15 inch	81.00	135.60	135.30	138.70	139.50	138.76	138.63	1.85	2.95	2.60	0.013	Concrete
I-1	I-2	0.010769	15 inch	65.00	137.50	136.80	141.00	140.30	141.00	140.71	2.25	2.25	4.30	0.013	Concrete
I-2	I-3	0.003947	18 inch	76.00	136.50	136.20	140.30	140.80	141.18	140.71	2.30	3.10	8.20	0.013	Concrete
I-3	I-4	0.003431	18 inch	204.00	136.10	135.40	140.80	140.80	140.49	138.86	3.20	3.90	9.40	0.013	Concrete
I-4	I-5	0.003175	24 inch	63.00	135.30	135.10	140.80	139.50	138.77	138.63	3.50	2.40	10.60	0.013	Concrete
I-5	I-7	0.003419	24 inch	117.00	135.00	134.60	139.50	138.30	138.49	138.10	2.50	1.70	13.20	0.013	Concrete
I-7	I-8	0.003333	30 inch	60.00	134.10	133.90	138.30	138.60	138.01	137.91	1.70	2.20	16.70	0.013	Concrete
I-8	J-1	0.003125	30 inch	32.00	133.80	133.70	138.60	138.40	137.76	137.68	2.30	2.20	21.00	0.013	Concrete
J-1	Outlet	0.060440	30 inch	91.00	133.50	128.00	138.40	137.50	137.54	137.30	2.40	7.00	21.00	0.013	Concrete

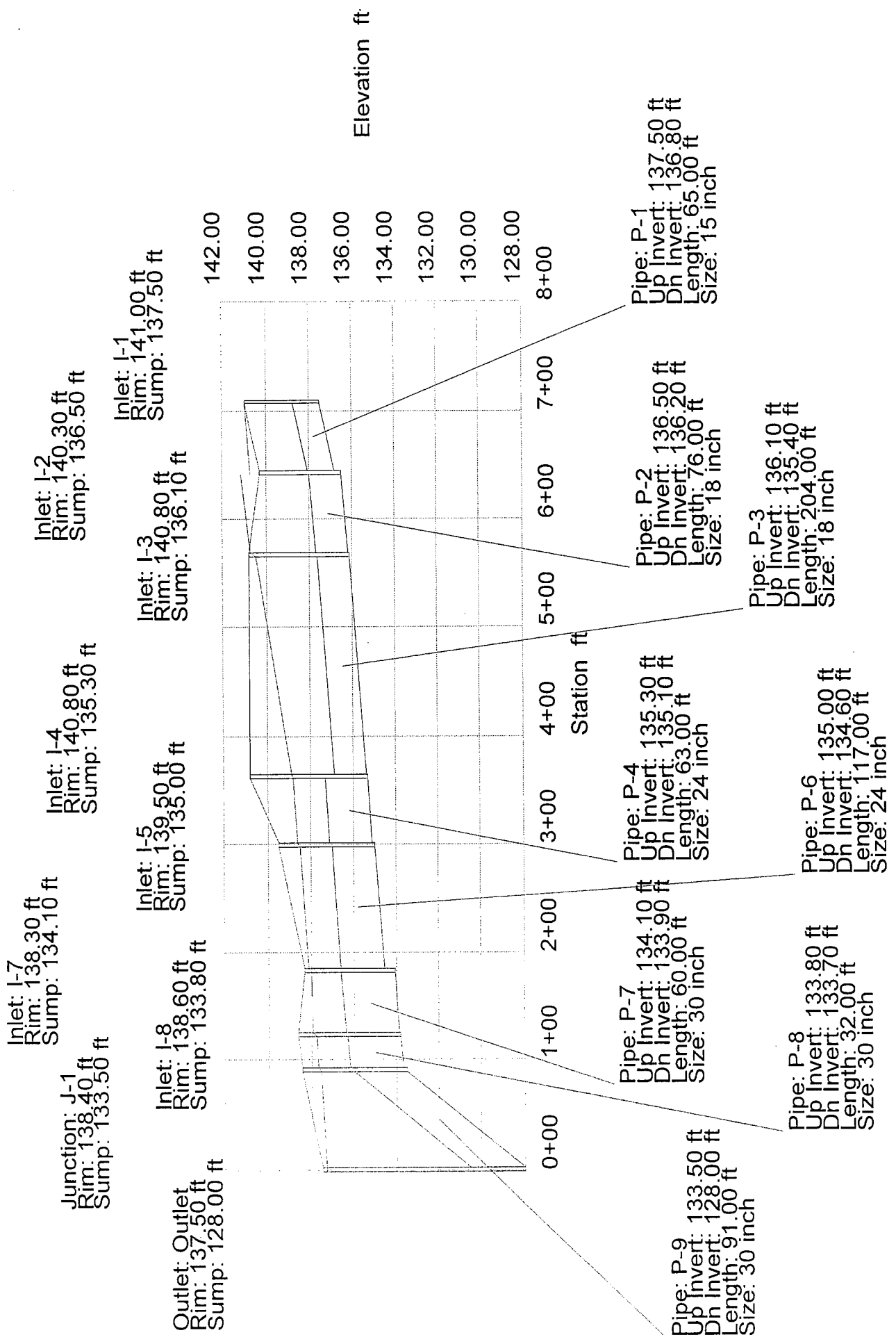

Inlet: I-6
 Rim: 138.70 ft
 Sump: 135.60 ft

Inlet: I-7
 Rim: 138.30 ft
 Sump: 134.10 ft

Junction: J-1
 Rim: 138.40 ft
 Sump: 133.50 ft

Inlet: I-5
 Rim: 139.50 ft
 Sump: 135.00 ft

Inlet: I-8
 Rim: 138.60 ft
 Sump: 133.80 ft

Outlet: Outlet
 Rim: 137.50 ft
 Sump: 128.00 ft

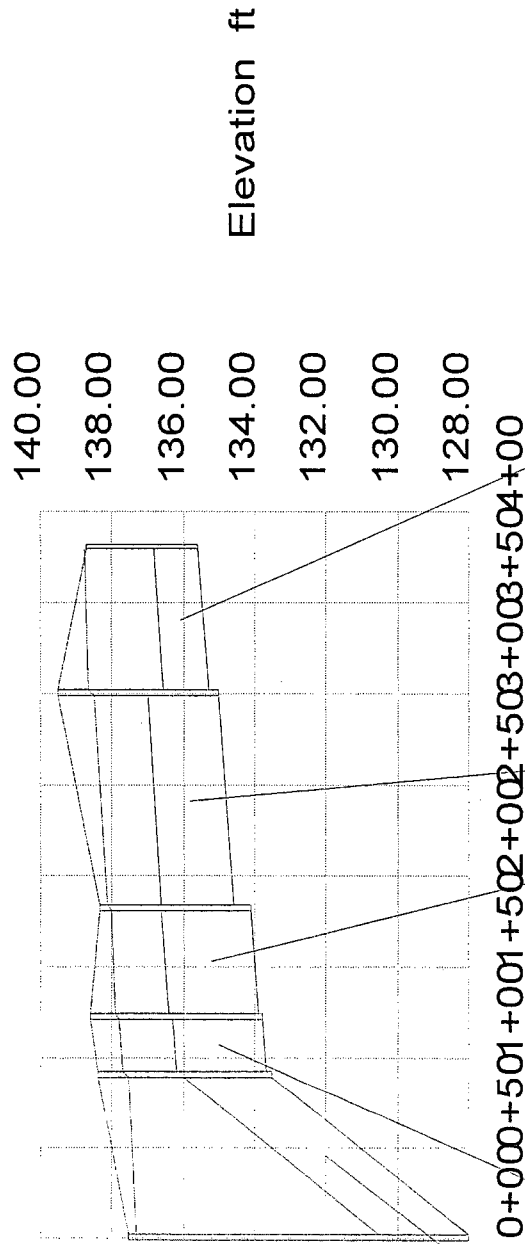

Pipe: P-8
 Up Invert: 133.80 ft
 Dn Invert: 133.70 ft
 Length: 32.00 ft
 Size: 30 inch

Pipe: P-6
 Up Invert: 135.00 ft
 Dn Invert: 134.60 ft
 Length: 117.00 ft
 Size: 24 inch

Pipe: P-5
 Up Invert: 135.60 ft
 Dn Invert: 135.30 ft
 Length: 81.00 ft
 Size: 15 inch

Pipe: P-9
 Up Invert: 133.50 ft
 Dn Invert: 128.00 ft
 Length: 91.00 ft
 Size: 30 inch

Pipe: P-7
 Up Invert: 134.10 ft
 Dn Invert: 133.90 ft
 Length: 60.00 ft
 Size: 30 inch

Node Report

Node	Weighted Roughness Coefficient	Total CA (acres)	Inlet TC (min)	System Flow Time (min)	System Intensity (in/hr)	Total Watershed (CIA) (cfs)	Additional Flow (cfs)	Known Flow (cfs)	Discharge (cfs)	Ground Elevation (ft)	HGL In (ft)	HGL Out (ft)	Inlet Intensity (in/hr)	Inlet Area (acres)
I-6	0.00	0.00	0.00	0.00	0.00	0.00	1.00	0.00	1.00	138.70	137.55	137.55	0.00	0.00
I-1	0.00	0.00	0.00	0.00	0.00	0.00	1.60	0.00	1.60	141.00	138.10	138.00	0.00	0.00
I-2	0.00	0.00	0.00	0.45	0.00	0.00	1.40	0.00	3.00	140.30	137.96	137.93	0.00	0.00
I-3	0.00	0.00	0.00	1.19	0.00	0.00	0.80	0.00	3.80	140.80	137.87	137.84	0.00	0.00
I-4	0.00	0.00	0.00	2.77	0.00	0.00	0.80	0.00	4.60	140.80	137.57	137.55	0.00	0.00
I-5	0.00	0.00	0.00	3.49	0.00	0.00	0.00	0.00	5.60	139.50	137.53	137.50	0.00	0.00
I-7	0.00	0.00	0.00	4.58	0.00	0.00	1.30	0.00	6.90	138.30	137.43	137.42	0.00	0.00
I-8	0.00	0.00	0.00	5.29	0.00	0.00	1.60	0.00	8.50	138.60	137.40	137.38	0.00	0.00
J-1	N/A	0.00	N/A	5.60	0.00	0.00	N/A	N/A	8.50	138.40	137.36	137.34	N/A	N/A
Outlet	N/A	0.00	N/A	6.48	0.00	0.00	N/A	N/A	N/A	137.50	137.30	137.30	N/A	N/A

Pipe Report

Upstream Node	Downstream Node	Constructed Slope (ft/ft)	Section Size	Length (ft)	Upstream Invert Elevation (ft)	Downstream Invert Elevation (ft)	Upstream Ground Elevation (ft)	Downstream Ground Elevation (ft)	Upstream HGL (ft)	Downstream HGL (ft)	Upstream Cover (ft)	Downstream Cover (ft)	Discharge (cfs)	Roughness	Section Material
I-6	I-5	0.003704	15 inch	81.00	135.60	135.30	138.70	139.50	137.55	137.53	1.85	2.95	1.00	0.013	Concrete
I-1	I-2	0.010769	15 inch	65.00	137.50	136.80	141.00	140.30	138.00	137.96	2.25	2.25	1.60	0.013	Concrete
I-2	I-3	0.003947	18 inch	76.00	136.50	136.20	140.30	140.80	137.93	137.87	2.30	3.10	3.00	0.013	Concrete
I-3	I-4	0.003431	18 inch	204.00	136.10	135.40	140.80	140.80	137.84	137.57	3.20	3.90	3.80	0.013	Concrete
I-4	I-5	0.003175	24 inch	63.00	135.30	135.10	140.80	139.50	137.55	137.53	3.50	2.40	4.60	0.013	Concrete
I-5	I-7	0.003419	24 inch	117.00	135.00	134.60	139.50	138.30	137.50	137.43	2.50	1.70	5.60	0.013	Concrete
I-7	I-8	0.003333	30 inch	60.00	134.10	133.90	138.30	138.60	137.42	137.40	1.70	2.20	6.90	0.013	Concrete
I-8	J-1	0.003125	30 inch	32.00	133.80	133.70	138.60	138.40	137.38	137.36	2.30	2.20	8.50	0.013	Concrete
J-1	Outlet	0.060440	30 inch	91.00	133.50	128.00	138.40	137.50	137.34	137.30	2.40	7.00	8.50	0.013	Concrete

Inlet: I-8
Rim: 138.60 ft
Sump: 133.80 ft

Inlet: I-5
Rim: 139.50 ft
Sump: 135.00 ft

Inlet: I-3
Rim: 140.80 ft
Sump: 136.10 ft

Inlet: I-1
Rim: 141.00 ft
Sump: 137.50 ft

Inlet: I-4
Rim: 140.80 ft
Sump: 135.30 ft

Inlet: I-7
Rim: 138.30 ft
Sump: 134.10 ft

Junction: J-1
Rim: 138.40 ft
Sump: 133.50 ft

Inlet: I-2
Rim: 140.30 ft
Sump: 136.50 ft

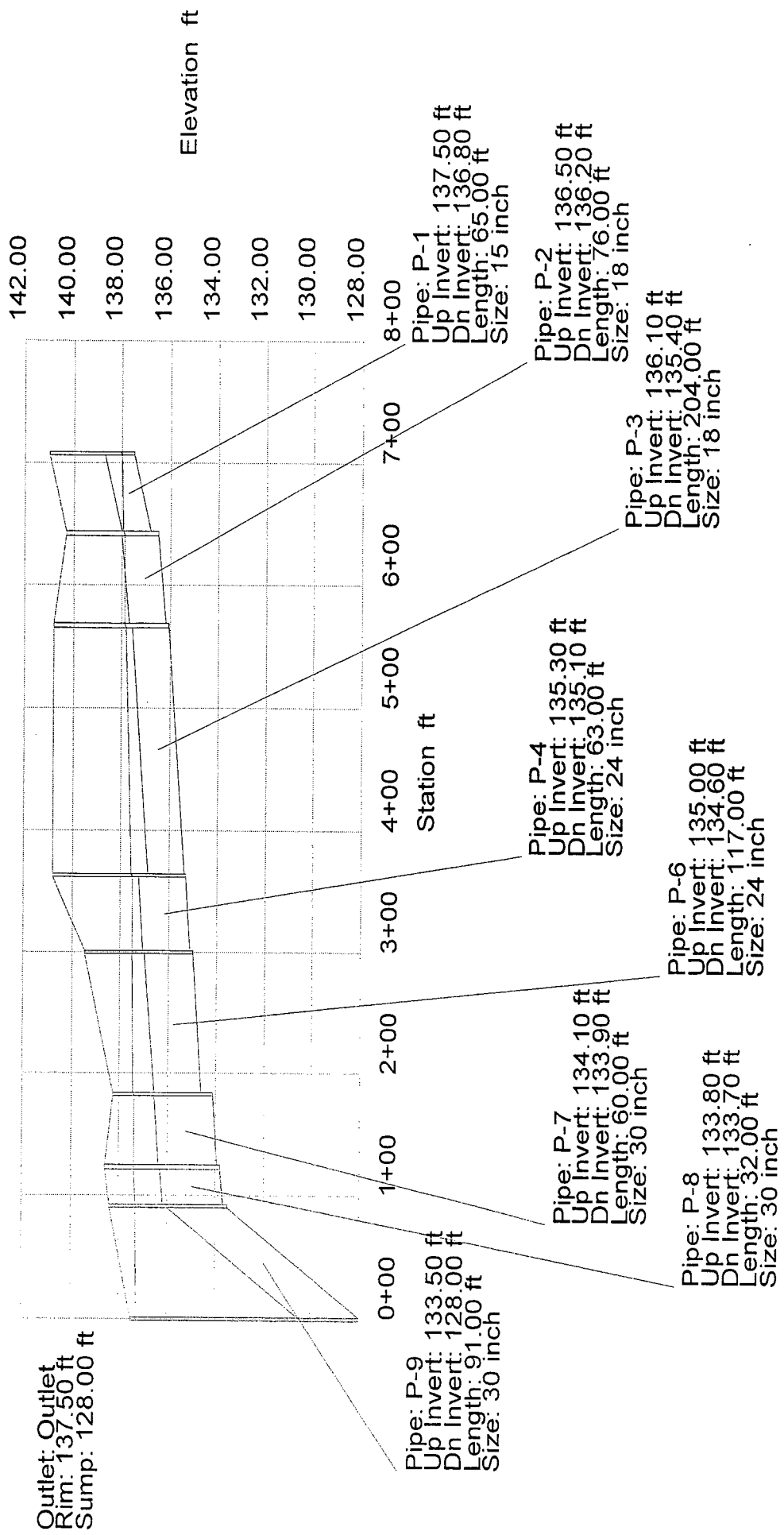

Inlet: I-8
 Rim: 138.60 ft
 Sump: 133.80 ft

Inlet: I-5
 Rim: 139.50 ft
 Sump: 135.00 ft

Junction: J-1
 Rim: 138.40 ft
 Sump: 133.50 ft

Inlet: I-7
 Rim: 138.30 ft
 Sump: 134.10 ft

Inlet: I-6
 Rim: 138.70 ft
 Sump: 135.60 ft

Outlet: Outlet
 Rim: 137.50 ft
 Sump: 128.00 ft

Station	Elevation ft
0+00	140.00
501	138.00
502	136.00
503	134.00
504	132.00
505	130.00
506	128.00

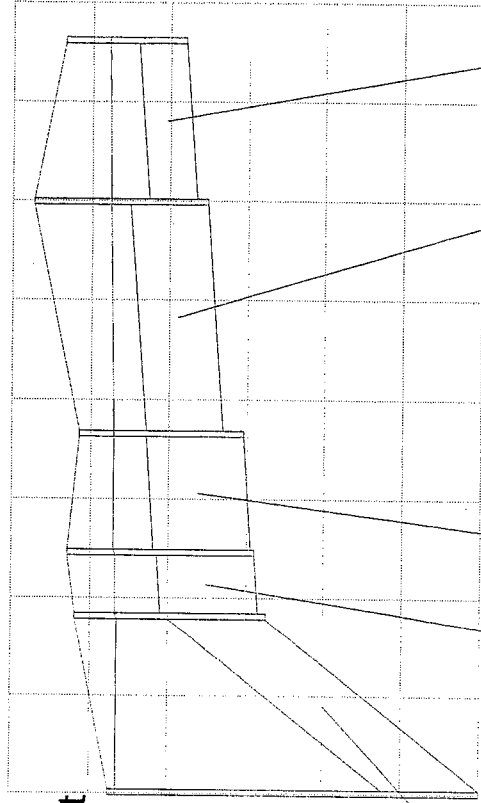

0+00+501+001+502+002+503+003+504+00

Station ft

Pipe: P-5
 Up Invert: 135.60 ft
 Dn Invert: 135.30 ft
 Length: 81.00 ft
 Size: 15 inch

Pipe: P-7
 Up Invert: 134.10 ft
 Dn Invert: 133.90 ft
 Length: 60.00 ft
 Size: 30 inch

Pipe: P-9
 Up Invert: 133.50 ft
 Dn Invert: 128.00 ft
 Length: 91.00 ft
 Size: 30 inch

Pipe: P-6
 Up Invert: 135.00 ft
 Dn Invert: 134.60 ft
 Length: 117.00 ft
 Size: 24 inch

Pipe: P-8
 Up Invert: 133.80 ft
 Dn Invert: 133.70 ft
 Length: 32.00 ft
 Size: 30 inch

Outlet

P-1

I-1

89

90

88

91

87

92

86

93

System Report

Pipe	Additional Flow (cfs)	Total Upstream Added (cfs)	Structure Discharge (cfs)	-Node- Upstream Downstream	-Section- Shape Size	Upstream Invert Elevation (ft)	Downstream Invert Elevation (ft)	-Ground- Upstream Downstream (ft)	-HGL- Upstream Downstream (ft)	-Slope- Energy Constructed (ft/ft)	-Section- Discharge Capacity (cfs)	Length (ft)	Average Velocity (ft/s)	Description
P-1	5.70	0.00	5.70	I-1 Outlet	Circular 15 inch	136.50	128.50	139.80 138.00	137.85 137.30	0.007787 0.114286	5.70 21.84	70.00	4.64	

Outlet: Outlet
Rim: 138.00 ft
Sump: 128.50 ft

Inlet: I-1
Rim: 139.80 ft
Sump: 136.50 ft

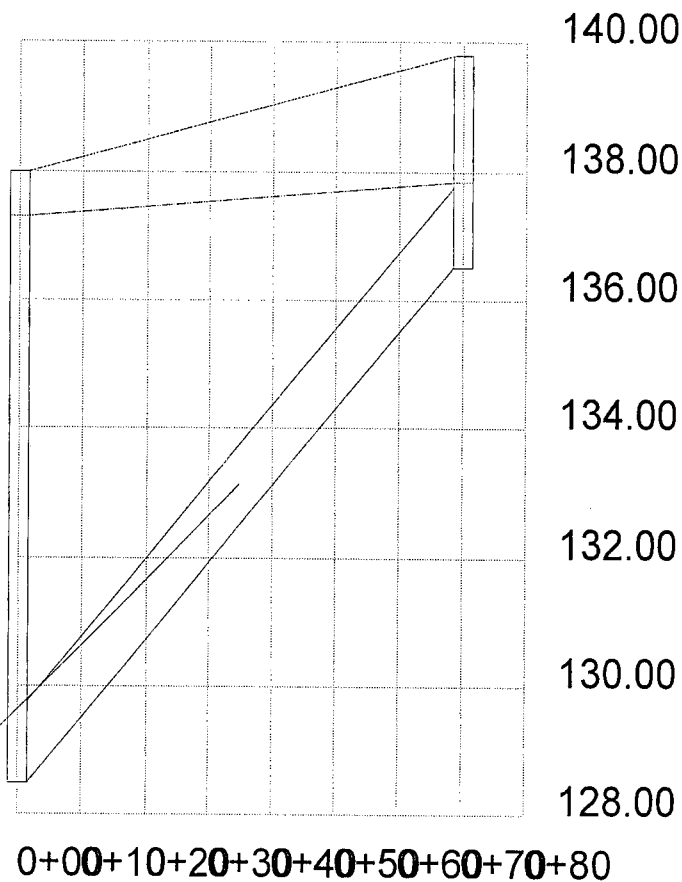

Pipe: P-1
Up Invert: 136.50 ft
Dn Invert: 128.50 ft
Length: 70.00 ft
Size: 15 inch

System Report

Pipe	Additional Flow (cfs)	Total Upstream Added (cfs)	Structure Discharge (cfs)	-Node- Upstream Downstream	-Section- Shape Size	Upstream Invert Elevation (ft)	Downstream Invert Elevation (ft)	-Ground- Upstream Downstream (ft)	-HGL- Upstream Downstream (ft)	-Slope- Energy Constructed (ft/ft)	-Section- Discharge Capacity (cfs)
P-1	2.10	0.00	2.10	I-1 Outlet	Circular 15 inch	136.50	128.50	139.80 138.00	137.33 137.30	0.001061 0.114286	2.10 21.84

Outlet: Outlet
Rim: 138.00 ft
Sump: 128.50 ft

Inlet: I-1
Rim: 139.80 ft
Sump: 136.50 ft

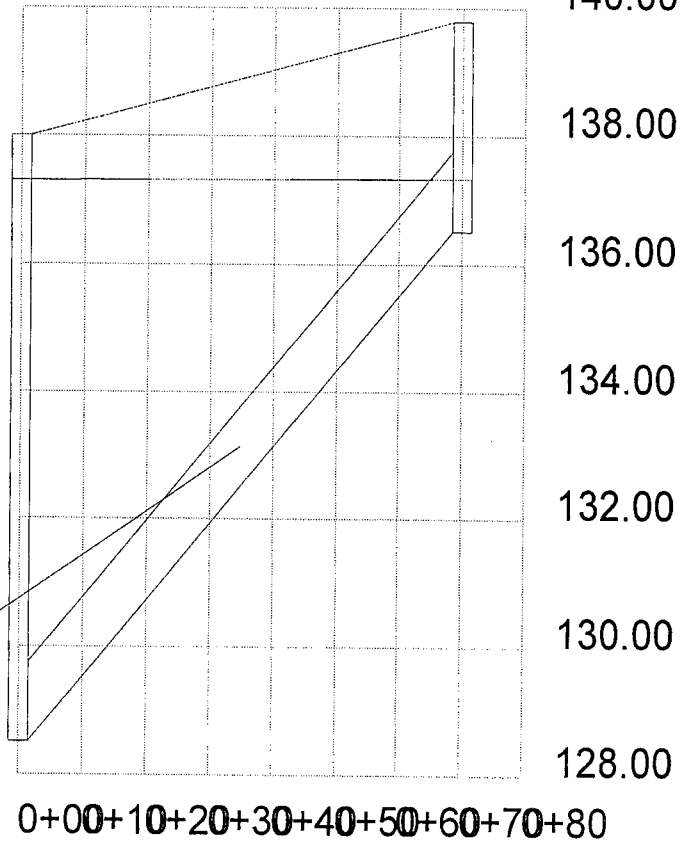

Elevation ft

Pipe: P-1
Up Invert: 136.50 ft
Dn Invert: 128.50 ft
Length: 70.00 ft
Size: 15 inch

Station ft

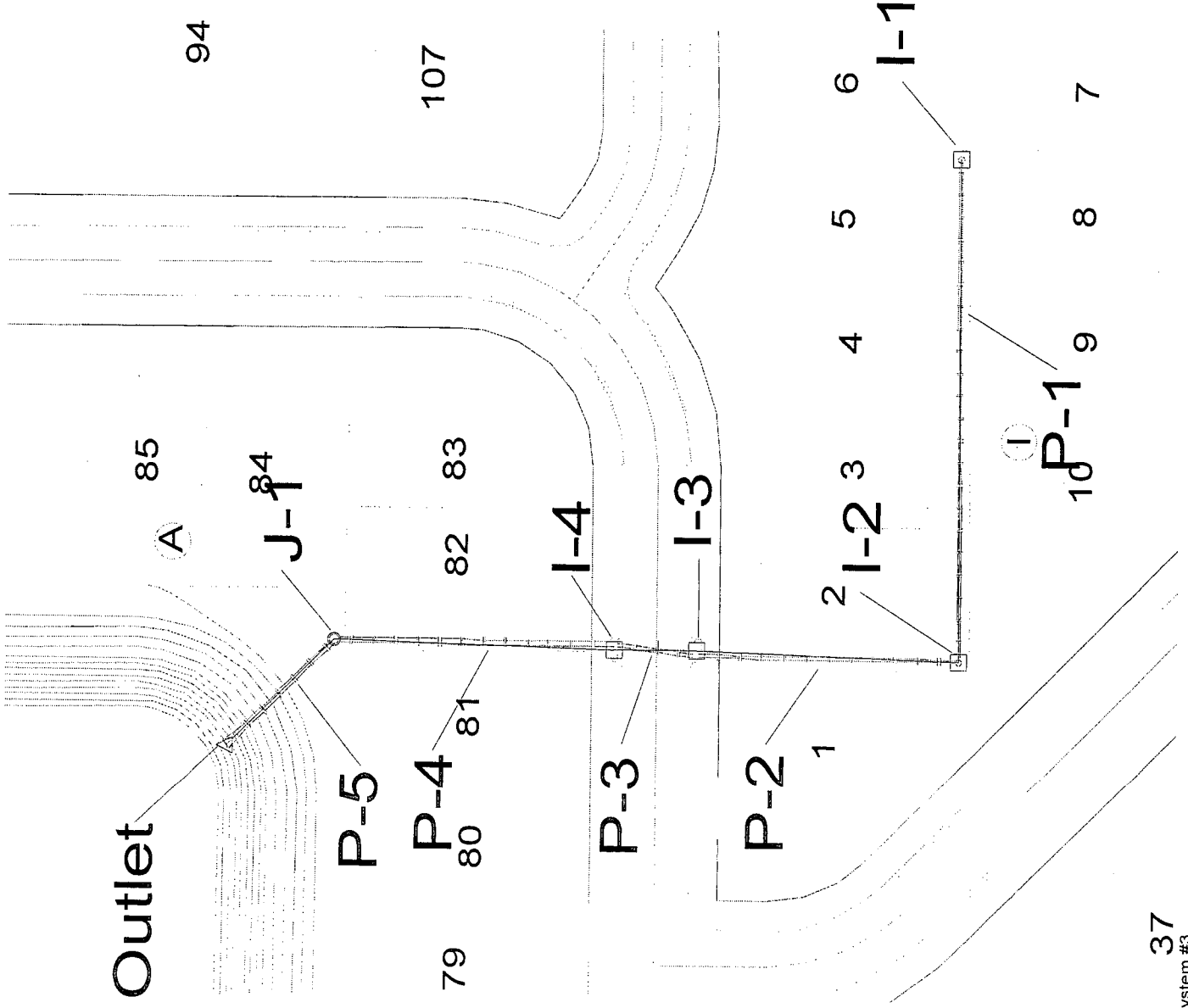

37

System Report

Pipe	Additional Flow (cfs)	Total Upstream Added (cfs)	Structure Discharge (cfs)	-Node- Upstream Downstream	-Section- Shape Size	Upstream Invert Elevation (ft)	Downstream Invert Elevation (ft)	-Ground- Upstream Downstream (ft)	-HGL- Upstream Downstream (ft)	-Slope- Energy Constructed (ft/ft)	-Section- Discharge Capacity (cfs)	Length (ft)	Average Velocity (ft/s)	Description
P-1	3.00	0.00	3.00	I-1	Circular	139.30	138.30	142.80	143.08	0.002157	3.00	247.00	2.44	
P-2	2.60	3.00	5.60	I-2	15 inch	138.00	137.60	143.20	142.55	0.004049	4.11	131.00	4.56	
P-3	15.00	5.60	20.60	I-3	Circular	137.10	136.90	141.40	141.40	0.007516	5.60	41.00	6.56	
P-4	15.00	20.60	35.60	I-4	15 inch	136.40	134.00	141.40	141.74	0.003053	3.57	141.00	11.33	
P-5	N/A	35.60	35.60	J-1	Circular	133.90	127.50	138.50	141.40	0.008293	20.60	75.00	7.25	
				Outlet	24 inch			138.00	141.77	0.004878	15.80			
					30 inch				138.27	0.024767	35.60			
									137.87	0.017021	29.51			
									137.30	0.007534	35.60			
										0.085333	119.81			

Inlet: I-1
 Rim: 142.80 ft
 Sump: 139.30 ft

Inlet: I-3
 Rim: 141.40 ft
 Sump: 137.10 ft

Junction: J-1
 Rim: 138.50 ft
 Sump: 133.90 ft

Inlet: I-2
 Rim: 143.20 ft
 Sump: 138.00 ft

Inlet: I-4
 Rim: 141.40 ft
 Sump: 136.40 ft

Outlet: Outlet
 Rim: 138.00 ft
 Sump: 127.50 ft

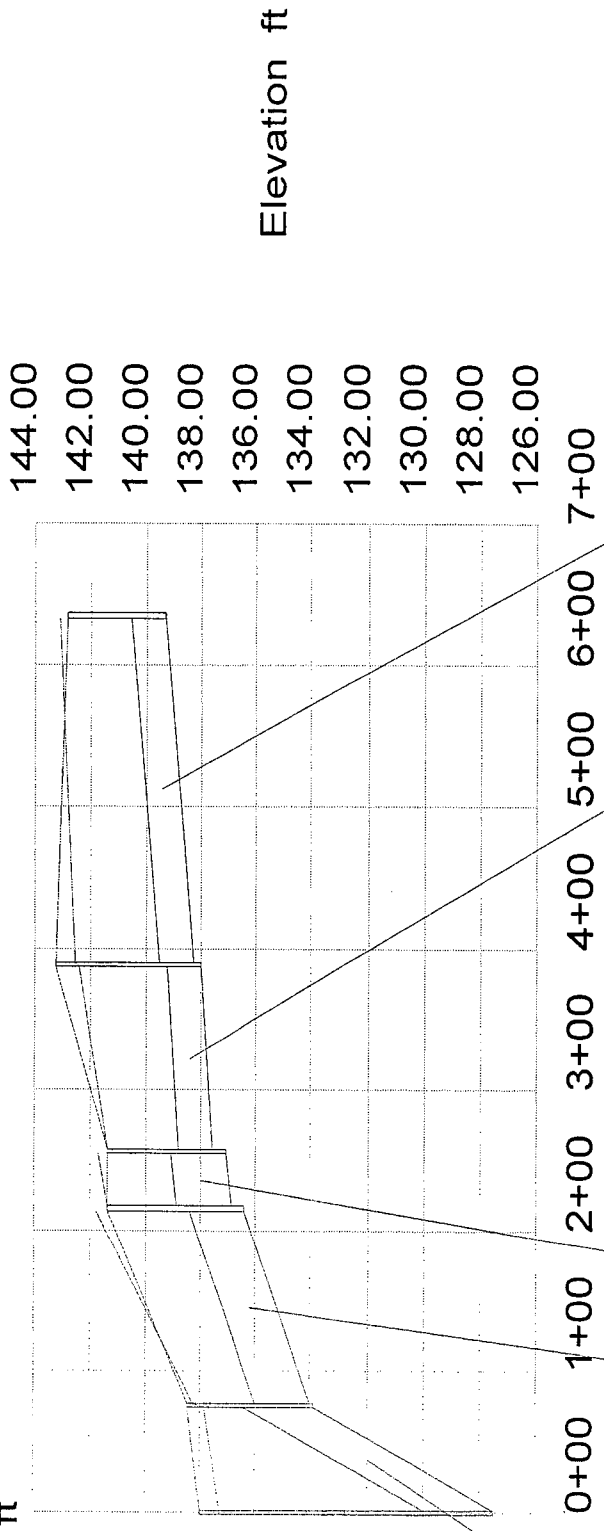

Elevation ft

Station ft

System Report

Pipe	Additional Flow (cfs)	Total Upstream Added (cfs)	Structure Discharge (cfs)	-Node- Upstream Downstream	-Section- Shape Size	Upstream Invert Elevation (ft)	Downstream Invert Elevation (ft)	-Ground- Upstream Downstream (ft)	-HGL- Upstream Downstream (ft)	-Slope- Energy Constructed (ft/ft)	-Section- Discharge Capacity (cfs)	Length (ft)	Average Velocity (ft/s)	Description
P-1	1.10	0.00	1.10	I-1	Circular	139.30	138.30	142.80	139.74	0.003892	1.10	247.00	2.53	
P-2	1.00	1.10	2.10	I-2	15 inch Circular	138.00	137.60	143.20	138.83	0.004049	4.11	131.00	2.29	
P-3	9.70	2.10	11.80	I-3	15 inch Circular	137.10	136.90	141.40	138.62	0.003053	3.57	41.00	5.66	
P-4	1.30	11.80	13.10	I-4	24 inch Circular	136.40	134.00	141.40	138.13	0.004878	11.80	141.00	5.11	
P-5	N/A	13.10	13.10	J-1	24 inch Circular	133.90	127.50	138.50	137.43	0.017021	29.51	75.00	2.67	
				Outlet	30 inch Circular			138.00	137.30	0.085333	119.81			

Junction: J-1
 Rim: 138.50 ft
 Sump: 133.90 ft

Inlet: I-3
 Rim: 141.40 ft
 Sump: 137.10 ft

Inlet: I-1
 Rim: 142.80 ft
 Sump: 139.30 ft

Inlet: I-2
 Rim: 143.20 ft
 Sump: 138.00 ft

Inlet: I-4
 Rim: 141.40 ft
 Sump: 136.40 ft

Outlet: Outlet
 Rim: 138.00 ft
 Sump: 127.50 ft

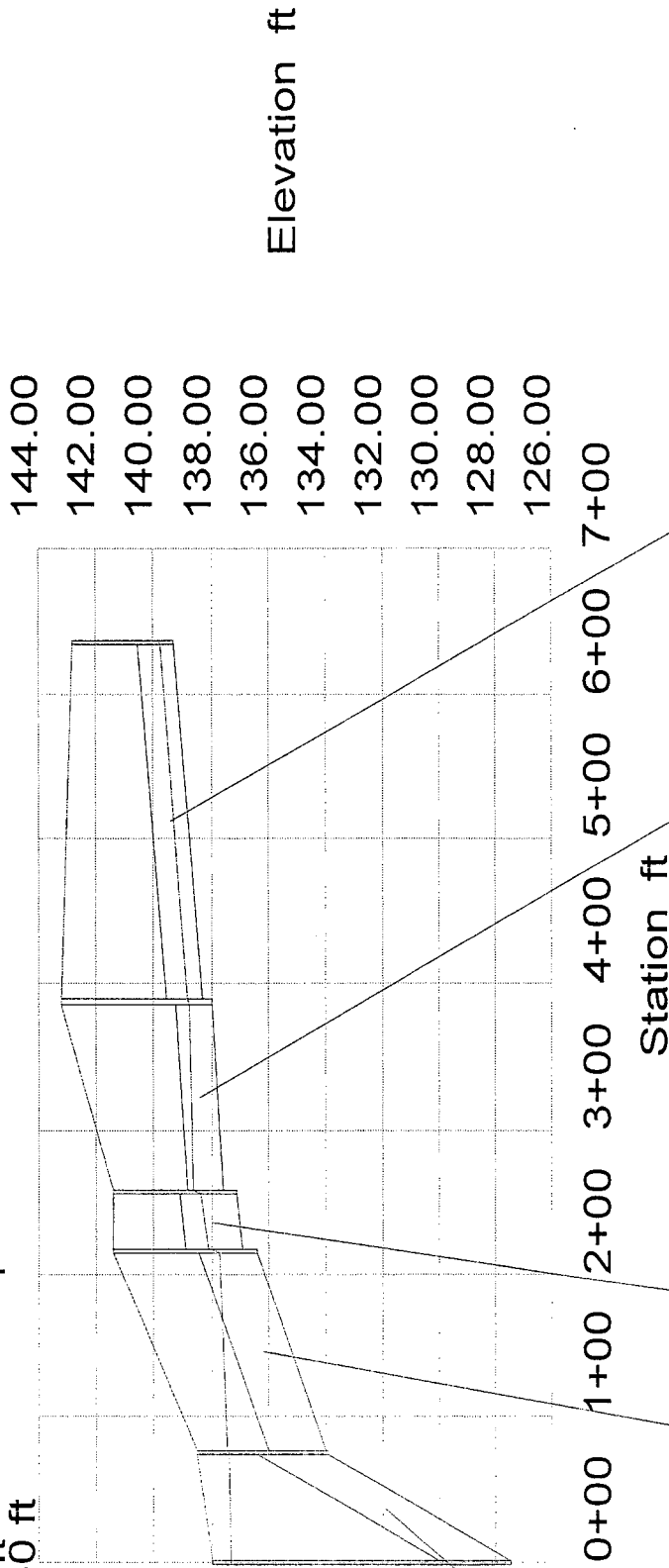

Pipe: P-1
 Up Invert: 139.30 ft
 Dn Invert: 138.30 ft
 Length: 247.00 ft
 Size: 15 inch

Pipe: P-2
 Up Invert: 138.00 ft
 Dn Invert: 137.60 ft
 Length: 131.00 ft
 Size: 15 inch

Pipe: P-3
 Up Invert: 137.10 ft
 Dn Invert: 136.90 ft
 Length: 41.00 ft
 Size: 24 inch

Pipe: P-4
 Up Invert: 136.40 ft
 Dn Invert: 134.00 ft
 Length: 141.00 ft
 Size: 24 inch

Pipe: P-5
 Up Invert: 133.90 ft
 Dn Invert: 127.50 ft
 Length: 75.00 ft
 Size: 30 inch

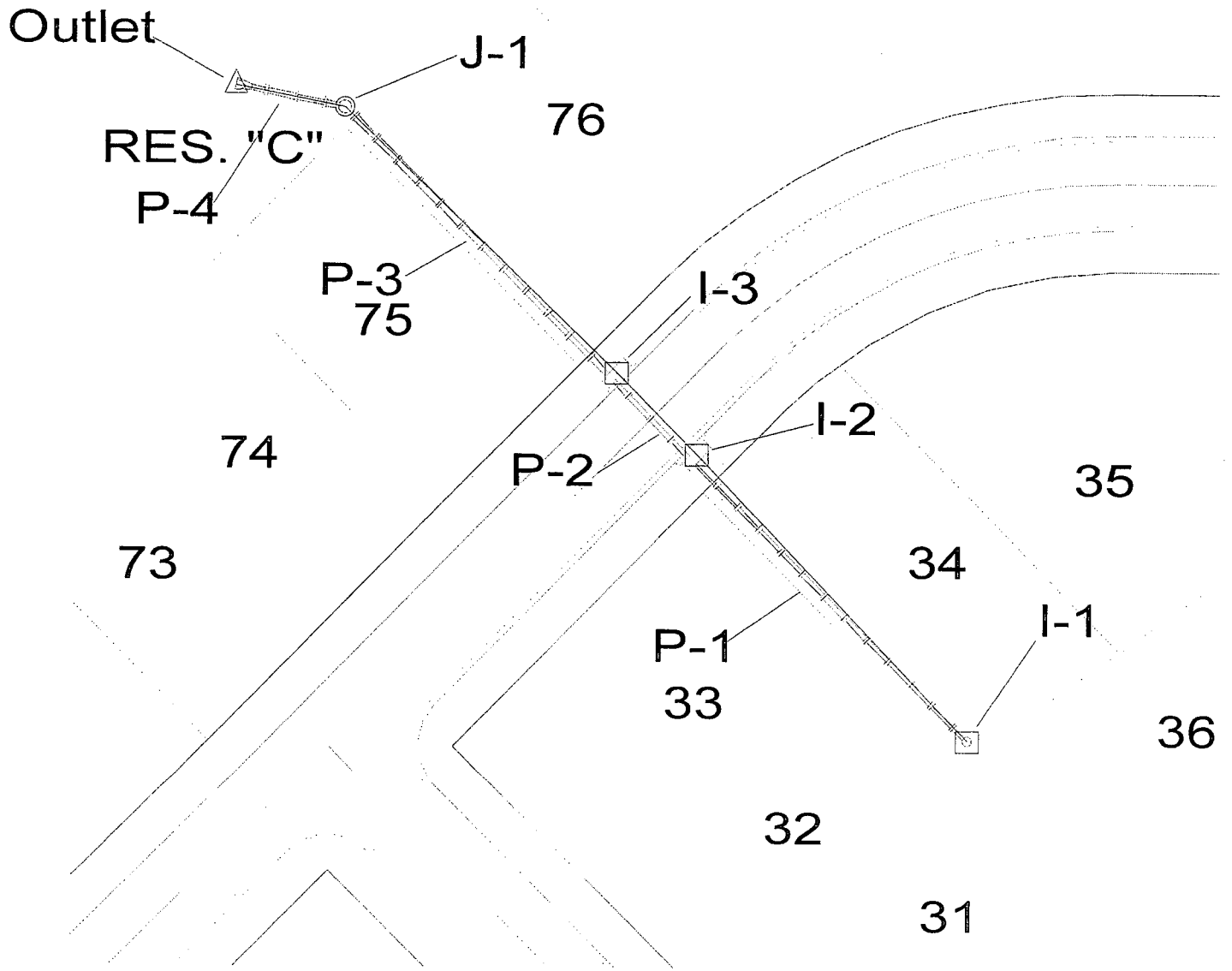

System Report

Pipe	Additional Flow (cfs)	Total Upstream Added (cfs)	Structure Discharge (cfs)	-Node- Upstream Downstream	-Section- Shape Size	Upstream Invert Elevation (ft)	Downstream Invert Elevation (ft)	-Ground- Upstream Downstream (ft)	-HGL- Upstream Downstream (ft)	-Slope- Energy Constructed (ft/ft)	-Section- Discharge Capacity (cfs)	Length (ft)	Average Velocity (ft/s)	Description
P-1	14.00	0.00	14.00	I-1	Circular 18 inch	136.40	135.80	139.90	143.50	0.017765	14.00	141.00	7.92	
P-2	15.00	14.00	29.00	I-2 I-3	Circular 24 inch	135.50	135.30	141.00	141.26	0.004255 0.016435	6.85 29.00	41.00	9.23	
P-3	15.00	29.00	44.00	I-3	Circular 30 inch	134.70	134.30	141.00	140.59	0.004878	15.80	136.00	8.96	
P-4	N/A	44.00	44.00	J-1 J-1 Outlet	Circular 30 inch	134.00	129.00	138.50 138.50	138.40 137.77	0.002941 0.011509	22.24 44.00	41.00	8.96	
								138.00	137.30	0.121951	143.23			

Junction: J-1
 Rim: 138.50 ft
 Sump: 134.00 ft

Inlet: I-2
 Rim: 141.00 ft
 Sump: 135.50 ft

Inlet: I-1
 Rim: 139.90 ft
 Sump: 136.40 ft

Outlet: Outlet
 Rim: 138.00 ft
 Sump: 129.00 ft

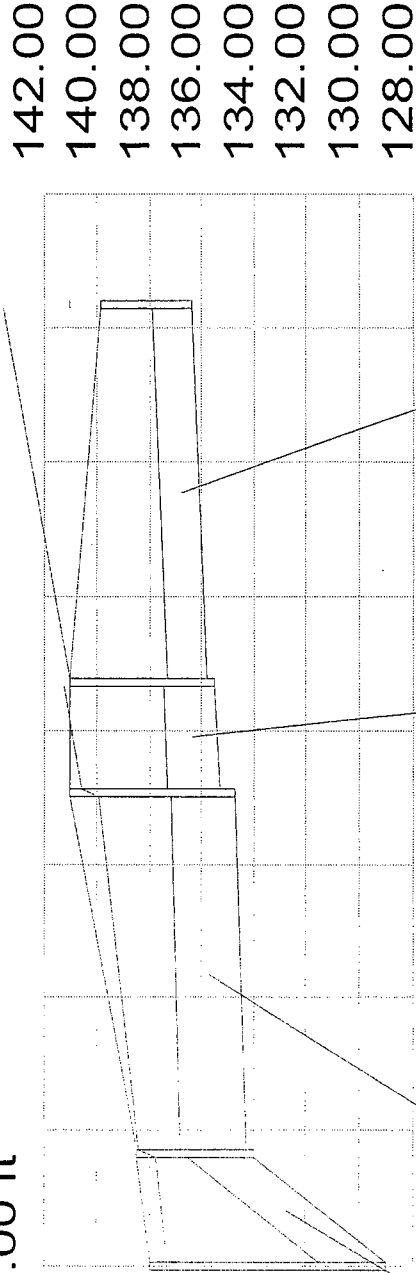

0+00 0+50 1+00 1+50 2+00 2+50 3+00 3+50 4+00

Station ft

Elevation ft

Pipe: P-3
 Up Invert: 134.70 ft
 Dn Invert: 134.30 ft
 Length: 136.00 ft
 Size: 30 inch

Pipe: P-1
 Up Invert: 136.40 ft
 Dn Invert: 135.80 ft
 Length: 141.00 ft
 Size: 18 inch

Pipe: P-4
 Up Invert: 134.00 ft
 Dn Invert: 129.00 ft
 Length: 41.00 ft
 Size: 30 inch

Pipe: P-2
 Up Invert: 135.50 ft
 Dn Invert: 135.30 ft
 Length: 41.00 ft
 Size: 24 inch

System Report

Pipe	Additional Flow (cfs)	Total Upstream Added (cfs)	Structure Discharge (cfs)	-Node- Upstream Downstream	-Section- Shape Size	Upstream Invert Elevation (ft)	Downstream Invert Elevation (ft)	-Ground- Upstream Downstream (ft)	-HGL- Upstream Downstream (ft)	-Slope- Energy Constructed (ft/ft)	-Section- Discharge Capacity (cfs)	Length (ft)	Average Velocity (ft/s)	Description
P-1	5.10	0.00	5.10	I-1	Circular 18 inch	136.40	135.80	139.90 141.00	138.46 138.12	0.002357 0.004255	5.10 6.85	141.00	2.89	
P-2	10.00	5.10	15.10	I-2 I-3	Circular 24 inch	135.50	135.30	141.00 141.00	137.94 137.76	0.004456 0.004878	15.10 15.80	41.00	4.81	
P-3	1.40	15.10	16.50	I-3 J-1	Circular 30 inch	134.70	134.30	141.00 138.50	137.67 137.45	0.001618 0.002941	16.50 22.24	136.00	3.36	
P-4	N/A	16.50	16.50	J-1 Outlet	Circular 30 inch	134.00	129.00	138.50 138.00	137.37 137.30	0.001618 0.121951	16.50 143.23	41.00	3.36	

Junction: J-1
 Rim: 138.50 ft
 Sump: 134.00 ft

Inlet: I-2
 Rim: 141.00 ft
 Sump: 135.50 ft

Inlet: I-1
 Rim: 139.90 ft
 Sump: 136.40 ft

Inlet: I-3
 Rim: 141.00 ft
 Sump: 134.70 ft

Outlet: Outlet
 Rim: 138.00 ft
 Sump: 129.00 ft

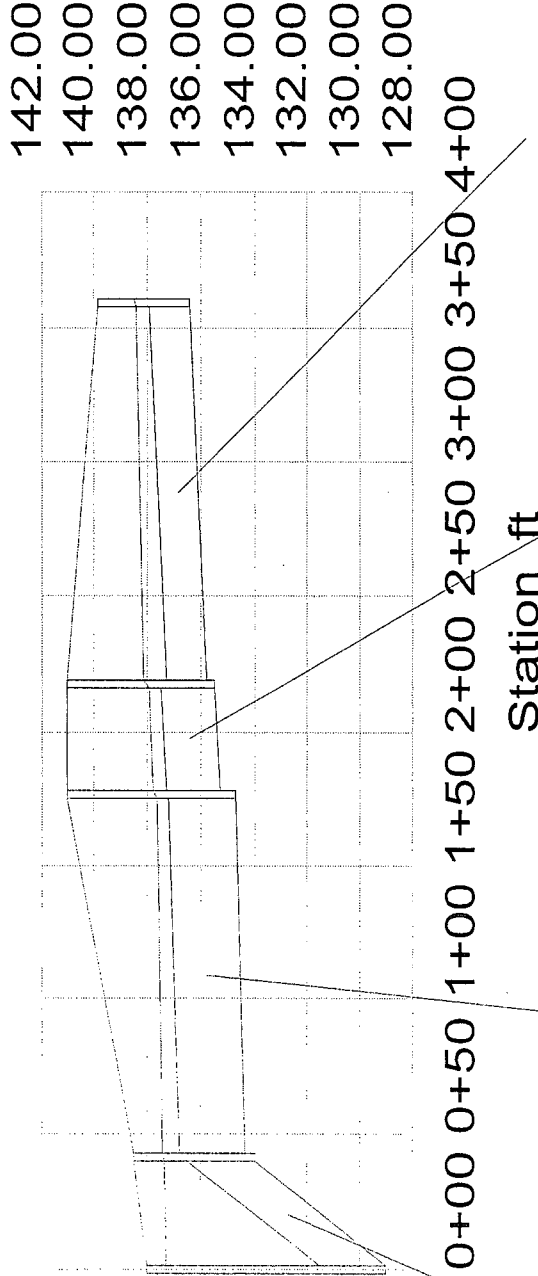

Pipe: P-1
 Up Invert: 136.40 ft
 Dn Invert: 135.80 ft
 Length: 141.00 ft
 Size: 18 inch

Pipe: P-2
 Up Invert: 135.50 ft
 Dn Invert: 135.30 ft
 Length: 41.00 ft
 Size: 24 inch

Pipe: P-3
 Up Invert: 134.70 ft
 Dn Invert: 134.30 ft
 Length: 136.00 ft
 Size: 30 inch

Pipe: P-4
 Up Invert: 134.00 ft
 Dn Invert: 129.00 ft
 Length: 41.00 ft
 Size: 30 inch

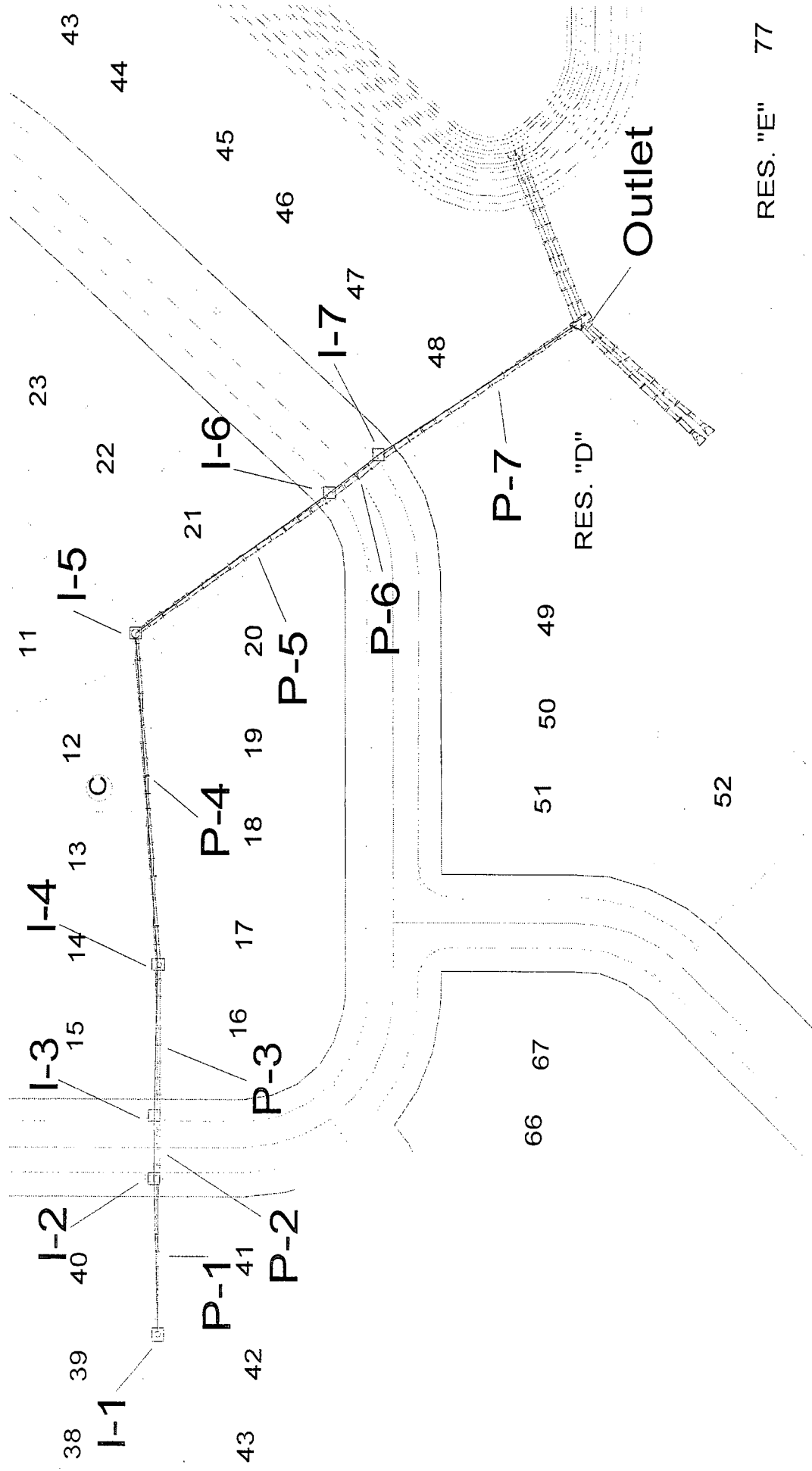

RES. "E" 77

System Report

Pipe	Additional Flow (cfs)	Total Upstream Added (cfs)	Structure Discharge (cfs)	-Node- Upstream Downstream	-Section- Shape Size	Upstream Invert Elevation (ft)	Downstream Invert Elevation (ft)	-Ground- Upstream Downstream (ft)	-HGL- Upstream Downstream (ft)	-Slope- Energy Constructed (ft/ft)	-Section- Discharge Capacity (cfs)	Length (ft)	Average Velocity (ft/s)	Description
P-1	15.00	0.00	15.00	I-1	Circular 18 inch	138.70	138.30	142.20	143.55	0.020394	15.00	101.00	8.49	
P-2	10.00	15.00	25.00	I-2	Circular 24 inch	137.80	137.70	142.90	141.49	0.003960	6.61	41.00	7.96	
P-3	1.30	25.00	26.30	I-3	Circular 30 inch	137.60	137.40	142.90	140.50	0.002439	11.17	101.00	5.37	
P-4	1.70	26.30	28.00	I-4	Circular 30 inch	137.30	134.90	142.00	139.86	0.001980	18.25	219.00	5.83	
P-5	7.00	28.00	35.00	I-5	Circular 36 inch	134.50	134.40	139.40	138.62	0.010959	42.94	159.00	4.95	
P-6	15.00	35.00	50.00	I-6	Circular 36 inch	134.30	134.20	140.30	137.99	0.000629	16.73	42.00	7.07	
P-7	15.00	50.00	65.00	I-7	Circular 36 inch	134.00	132.50	140.30	137.37	0.002381	32.54	159.00	10.24	
				Outlet				138.00	134.97	0.009434	64.78			

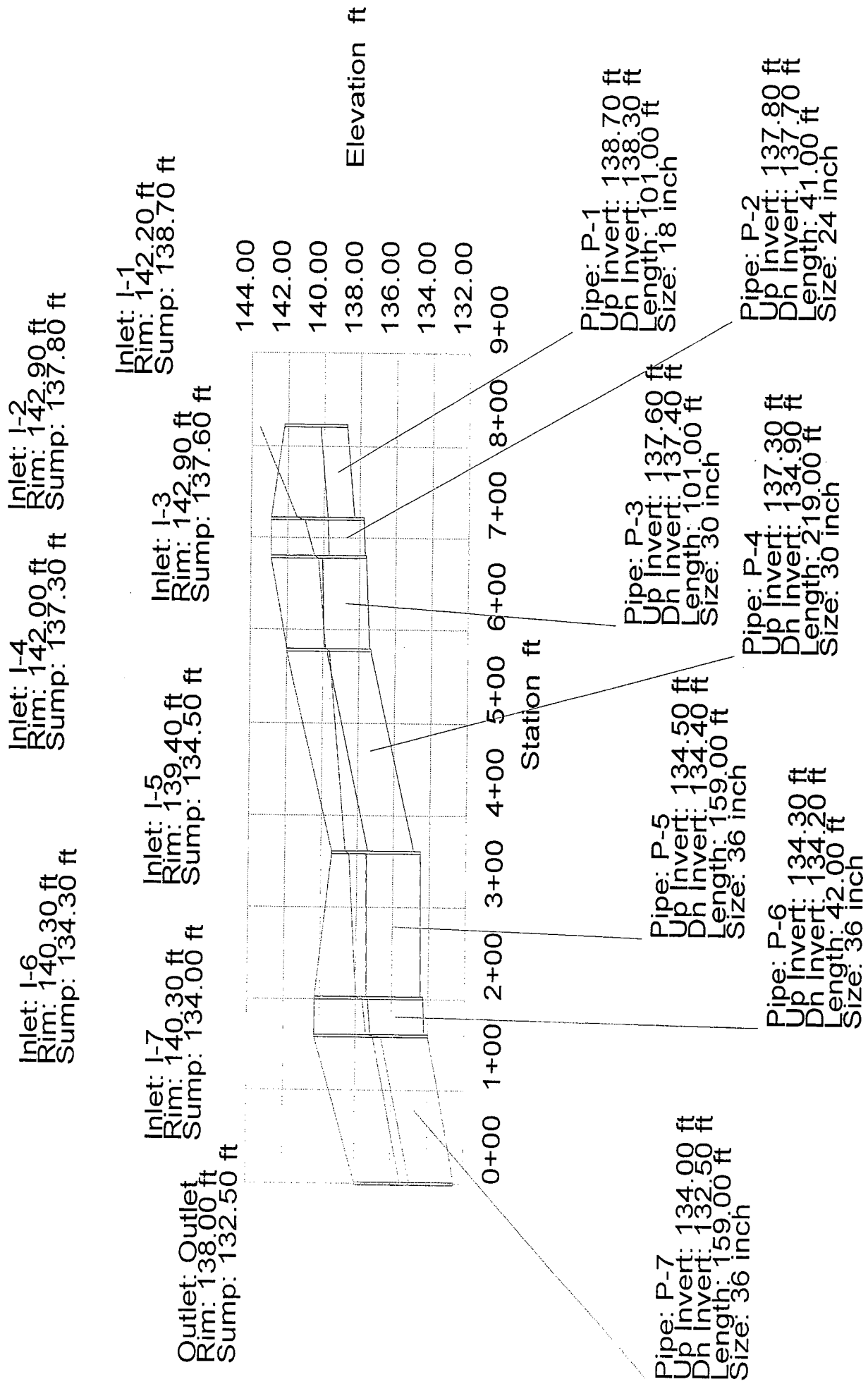

System Report

Pipe	Additional Flow (cfs)	Total Upstream Added (cfs)	Structure Discharge (cfs)	-Node- Upstream Downstream	-Section- Shape Size	Upstream Invert Elevation (ft)	Downstream Invert Elevation (ft)	-Ground- Upstream Downstream (ft)	-HGL- Upstream Downstream (ft)	-Slope- Energy Constructed (ft/ft)	-Section- Discharge Capacity (cfs)	Length (ft)	Average Velocity (ft/s)	Description
P-1	5.60	0.00	5.60	I-1	Circular	138.70	138.30	142.20	139.76	0.004250	5.60	101.00	4.44	
P-2	3.70	5.60	9.30	I-2	18 inch Circular	137.80	137.70	142.90	139.26	0.003960	6.61	41.00	4.28	
P-3	0.50	9.30	9.80	I-3	24 inch Circular	137.60	137.40	142.90	138.99	0.002899	11.17	101.00	4.10	
P-4	0.60	9.80	10.40	I-4	30 inch Circular	137.30	134.90	142.00	138.87	0.002371	9.80	219.00	4.37	
P-5	2.60	10.40	13.00	I-5	30 inch Circular	134.50	134.40	139.40	138.38	0.010330	10.40	159.00	3.11	
P-6	1.90	13.00	14.90	I-6	36 inch Circular	134.30	134.20	140.30	136.32	0.010959	13.00	42.00	3.58	
P-7	10.20	14.90	25.10	I-7	36 inch Circular	134.00	132.50	140.30	136.25	0.000975	16.73	159.00	5.23	
				Outlet	36 inch Circular			138.00	136.08	0.000629	64.78			

Inlet: I-1
Rim: 142.20 ft
Sump: 138.70 ft

Inlet: I-3
Rim: 142.90 ft
Sump: 137.60 ft

Inlet: I-5
Rim: 139.40 ft
Sump: 134.50 ft

Inlet: I-7
Rim: 140.30 ft
Sump: 134.00 ft

Inlet: I-2
Rim: 142.90 ft
Sump: 137.80 ft

Inlet: I-4
Rim: 142.00 ft
Sump: 137.30 ft

Inlet: I-6
Rim: 140.30 ft
Sump: 134.30 ft

Outlet: Outlet
Rim: 138.00 ft
Sump: 132.50 ft

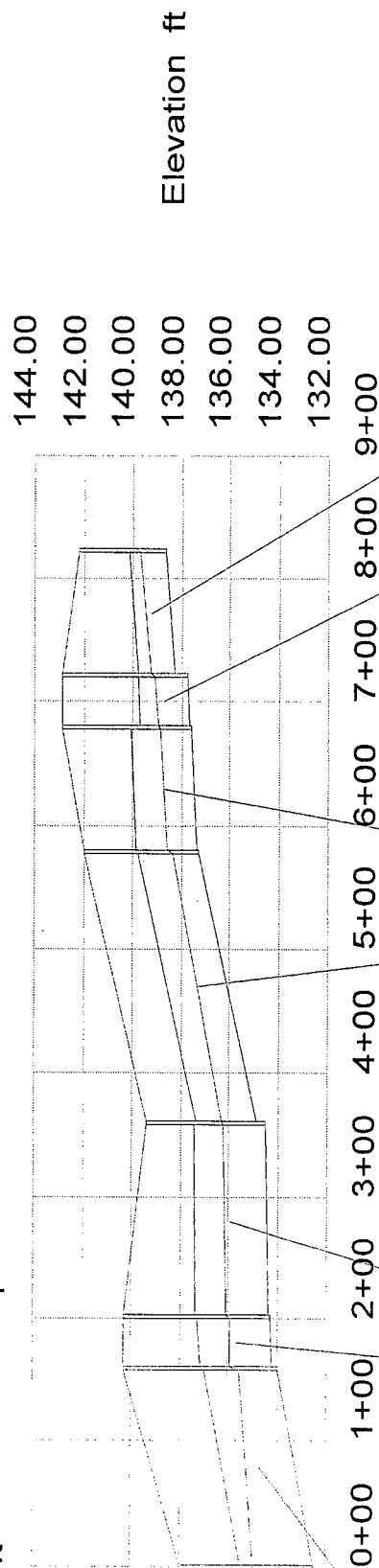

Pipe: P-1
Up Invert: 138.70 ft
Dn Invert: 138.30 ft
Length: 101.00 ft
Size: 18 inch

Pipe: P-2
Up Invert: 137.80 ft
Dn Invert: 137.70 ft
Length: 41.00 ft
Size: 24 inch

Pipe: P-3
Up Invert: 137.60 ft
Dn Invert: 137.40 ft
Length: 101.00 ft
Size: 30 inch

Pipe: P-4
Up Invert: 137.30 ft
Dn Invert: 134.90 ft
Length: 219.00 ft
Size: 30 inch

Pipe: P-5
Up Invert: 134.50 ft
Dn Invert: 134.40 ft
Length: 159.00 ft
Size: 36 inch

Pipe: P-6
Up Invert: 134.30 ft
Dn Invert: 134.20 ft
Length: 42.00 ft
Size: 36 inch

Pipe: P-7
Up Invert: 134.00 ft
Dn Invert: 132.50 ft
Length: 159.00 ft
Size: 36 inch

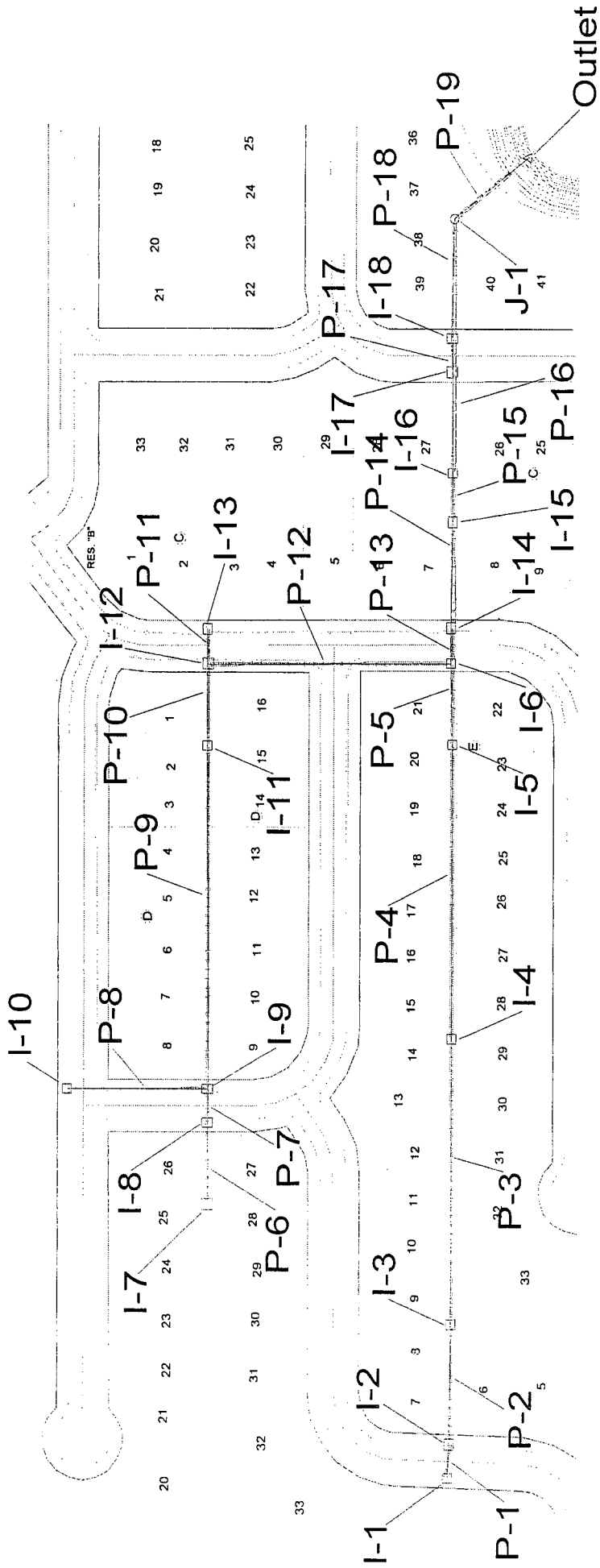

System Report

Pipe	Additional Flow (cfs)	Total Upstream Added (cfs)	Structure Discharge (cfs)	-Node- Upstream Downstream	-Section- Shape Size	Upstream Invert Elevation (ft)	Downstream Invert Elevation (ft)	-Ground- Upstream Downstream (ft)	-HGL- Upstream Downstream (ft)	-Slope- Energy Constructed (ft/ft)	-Section- Discharge Capacity (cfs)	Length (ft)	Average Velocity (ft/s)	Description
P-11	3.30	0.00	3.30	I-13	Circular 15 inch	139.50	137.80	143.30	142.63	0.002610	3.30	42.00	2.69	
P-8	5.20	0.00	5.20	I-10	Circular 15 inch	142.20	139.00	145.70	145.59	0.006481	5.20	176.00	4.24	
P-6	13.00	0.00	13.00	I-7	Circular 18 inch	139.80	139.50	144.70	144.45	0.018182	8.71	101.00	7.36	
P-7	5.70	13.00	18.70	I-8	Circular 24 inch	139.00	138.50	144.70	144.73	0.006834	18.70	41.00	5.95	
P-9	2.20	23.90	26.10	I-9	Circular 30 inch	138.00	136.30	144.70	144.45	0.012195	24.98	422.00	5.32	
P-10	7.40	26.10	33.50	I-11	Circular 36 inch	136.20	135.90	142.30	142.52	0.004028	26.03	101.00	4.74	
P-12	3.90	36.80	40.70	I-12	Circular 36 inch	135.80	135.40	143.30	142.26	0.002523	33.50	303.00	5.76	
P-1	5.20	0.00	5.20	I-6	Circular 18 inch	141.00	140.80	141.70	141.13	0.001320	24.23	41.00	2.95	
P-2	5.20	5.20	10.40	I-2	Circular 24 inch	140.30	139.00	144.30	142.48	0.002436	5.20	41.00	2.95	
P-3	3.90	10.40	14.30	I-3	Circular 30 inch	138.50	137.50	143.00	142.39	0.004878	7.34	144.00	3.31	
P-4	5.20	14.30	19.50	I-4	Circular 36 inch	137.00	135.70	142.00	142.30	0.002115	10.40	352.00	2.91	
P-5	5.70	19.50	25.20	I-5	Circular 42 inch	135.60	135.40	140.70	141.13	0.000855	19.50	360.00	2.76	
P-13	13.00	65.90	78.90	I-6	Circular 48 inch	135.30	135.20	141.70	141.28	0.003611	40.08	101.00	3.57	
P-14	13.00	78.90	91.90	I-14	Circular 48 inch	135.00	133.40	141.70	141.13	0.001980	29.68	43.00	8.20	
P-15	5.20	91.90	97.10	I-15	Circular 48 inch	133.30	133.20	139.40	140.61	0.006151	78.90	130.00	7.31	
P-16	5.70	97.10	102.80	I-16	Circular 48 inch	133.10	132.90	139.40	139.67	0.012308	159.35	60.00	7.73	
P-17	7.00	102.80	109.80	I-17	Circular 48 inch	132.80	132.70	140.50	139.40	0.004570	97.10	124.00	8.18	
P-18	3.00	109.80	112.80	I-18	Circular 48 inch	132.60	132.00	140.50	138.08	0.001667	58.64	41.00	8.74	
P-19	N/A	112.80	112.80	J-1	Circular 48 inch	131.90	126.00	138.00	137.84	0.005122	102.80	145.00	8.98	
				Outlet	Circular 48 inch			138.00	136.32	0.001613	57.69	118.00	9.09	
								138.00	135.66	0.005844	109.80			
								138.00	135.00	0.002439	70.94			
								138.00	135.00	0.006167	112.80			
								138.00	135.00	0.004138	92.40			
								138.00	135.00	0.006150	112.80			
								138.00	135.00	0.050000	321.18			

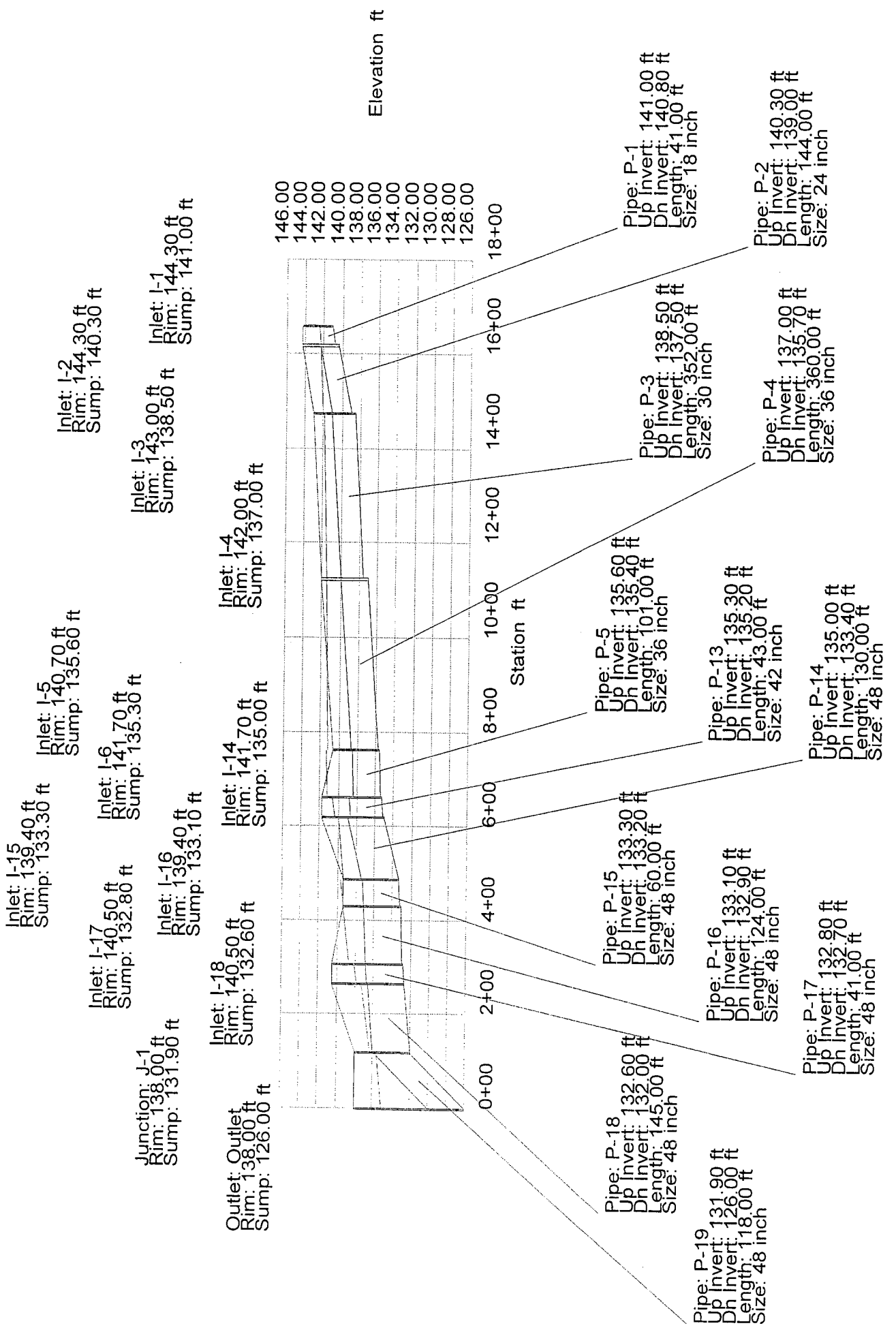

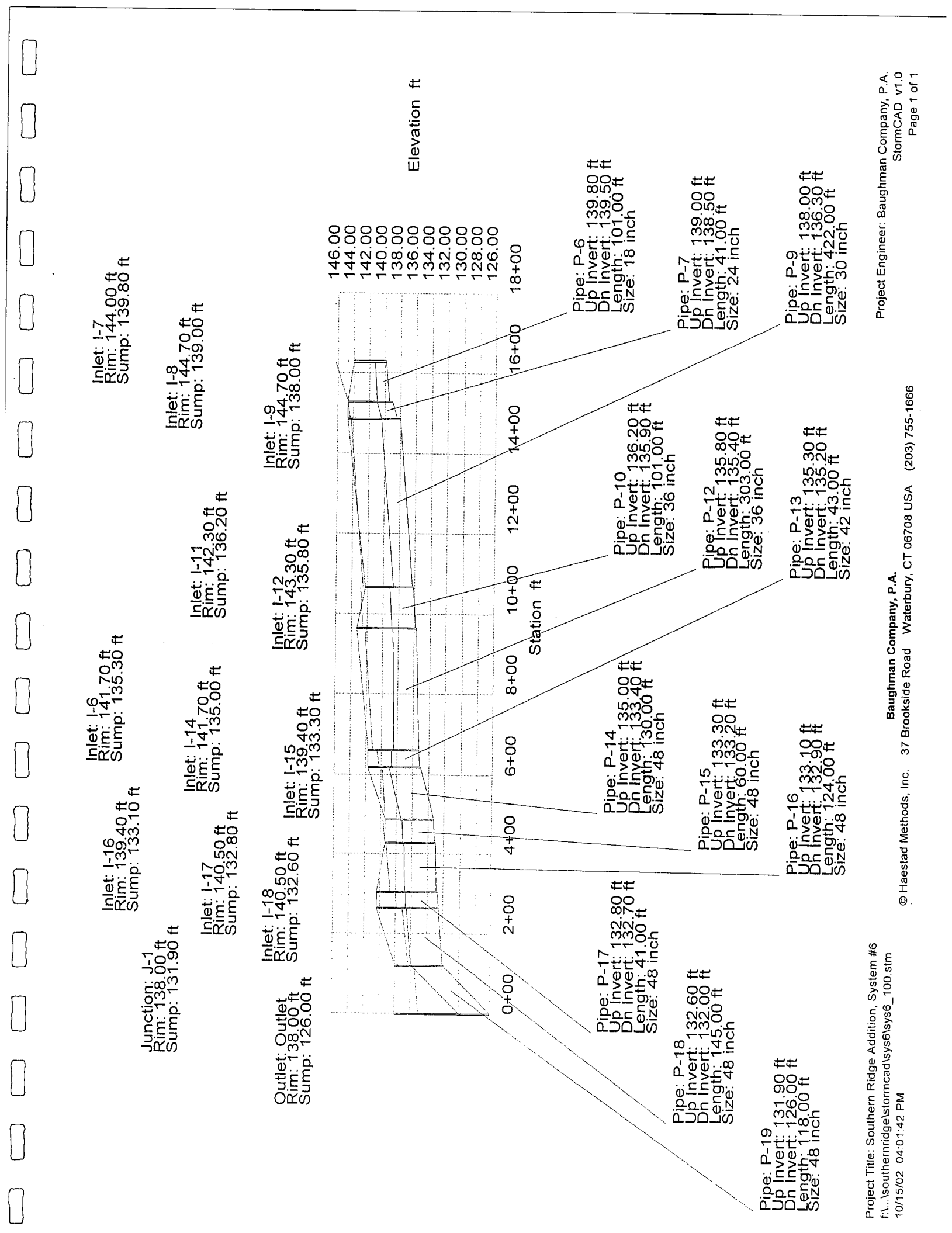

Inlet: I-7
Rim: 144.00 ft
Sump: 139.80 ft

Inlet: I-8
Rim: 144.70 ft
Sump: 139.00 ft

Inlet: I-9
Rim: 144.70 ft
Sump: 138.00 ft

Pipe: P-6
Up Invert: 139.80 ft
Dn Invert: 139.50 ft
Length: 101.00 ft
Size: 18 inch

Pipe: P-7
Up Invert: 139.00 ft
Dn Invert: 138.50 ft
Length: 41.00 ft
Size: 24 inch

Pipe: P-9
Up Invert: 138.00 ft
Dn Invert: 136.30 ft
Length: 422.00 ft
Size: 30 inch

Inlet: I-6
Rim: 141.70 ft
Sump: 135.30 ft

Inlet: I-11
Rim: 142.30 ft
Sump: 136.20 ft

Inlet: I-12
Rim: 143.30 ft
Sump: 135.80 ft

Pipe: P-10
Up Invert: 136.20 ft
Dn Invert: 135.90 ft
Length: 101.00 ft
Size: 36 inch

Pipe: P-12
Up Invert: 135.80 ft
Dn Invert: 135.40 ft
Length: 303.00 ft
Size: 36 inch

Pipe: P-13
Up Invert: 135.30 ft
Dn Invert: 135.20 ft
Length: 43.00 ft
Size: 42 inch

Inlet: I-16
Rim: 139.40 ft
Sump: 133.10 ft

Inlet: I-14
Rim: 141.70 ft
Sump: 135.00 ft

Inlet: I-15
Rim: 139.40 ft
Sump: 133.30 ft

Pipe: P-14
Up Invert: 135.00 ft
Dn Invert: 133.40 ft
Length: 130.00 ft
Size: 48 inch

Pipe: P-15
Up Invert: 133.30 ft
Dn Invert: 133.20 ft
Length: 60.00 ft
Size: 48 inch

Pipe: P-16
Up Invert: 133.10 ft
Dn Invert: 132.90 ft
Length: 124.00 ft
Size: 48 inch

Junction: J-1
Rim: 138.00 ft
Sump: 131.90 ft

Inlet: I-17
Rim: 140.50 ft
Sump: 132.80 ft

Inlet: I-18
Rim: 140.50 ft
Sump: 132.60 ft

Pipe: P-17
Up Invert: 132.80 ft
Dn Invert: 132.70 ft
Length: 41.00 ft
Size: 48 inch

Pipe: P-18
Up Invert: 132.60 ft
Dn Invert: 132.00 ft
Length: 145.00 ft
Size: 48 inch

Pipe: P-19
Up Invert: 131.90 ft
Dn Invert: 126.00 ft
Length: 118.00 ft
Size: 48 inch

Outlet: Outlet
Rim: 138.00 ft
Sump: 126.00 ft

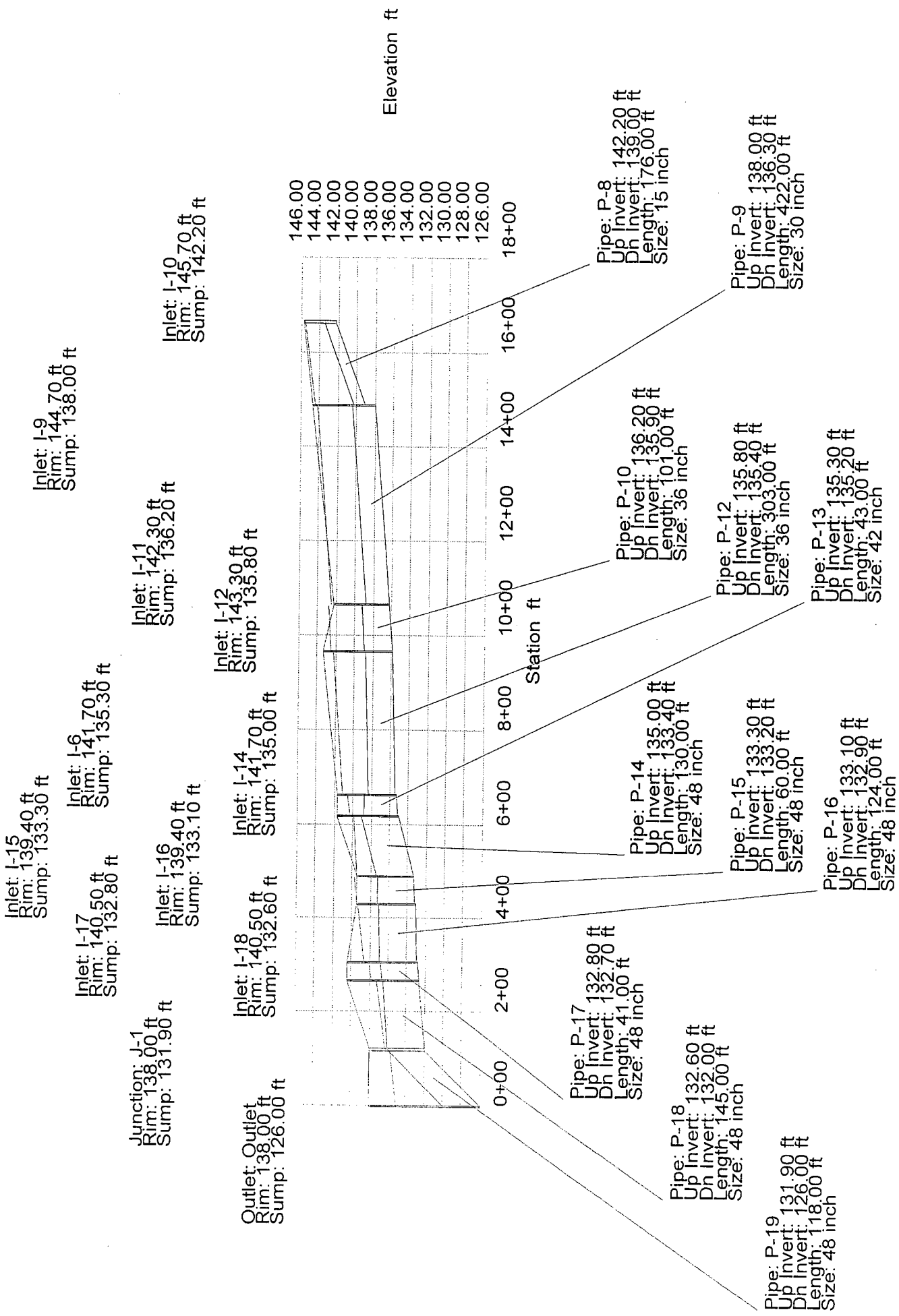

Inlet: I-18
Rim: 140.50 ft
Sump: 132.60 ft

Inlet: I-15
Rim: 139.40 ft
Sump: 133.30 ft

Inlet: I-12
Rim: 143.30 ft
Sump: 135.80 ft

Junction: J-1
Rim: 138.00 ft
Sump: 131.90 ft

Inlet: I-16
Rim: 139.40 ft
Sump: 133.10 ft

Inlet: I-6
Rim: 141.70 ft
Sump: 135.30 ft

Outlet: Outlet
Rim: 138.00 ft
Sump: 126.00 ft

Inlet: I-17
Rim: 140.50 ft
Sump: 132.80 ft

Inlet: I-14
Rim: 141.70 ft
Sump: 135.00 ft

Inlet: I-13
Rim: 143.30 ft
Sump: 139.50 ft

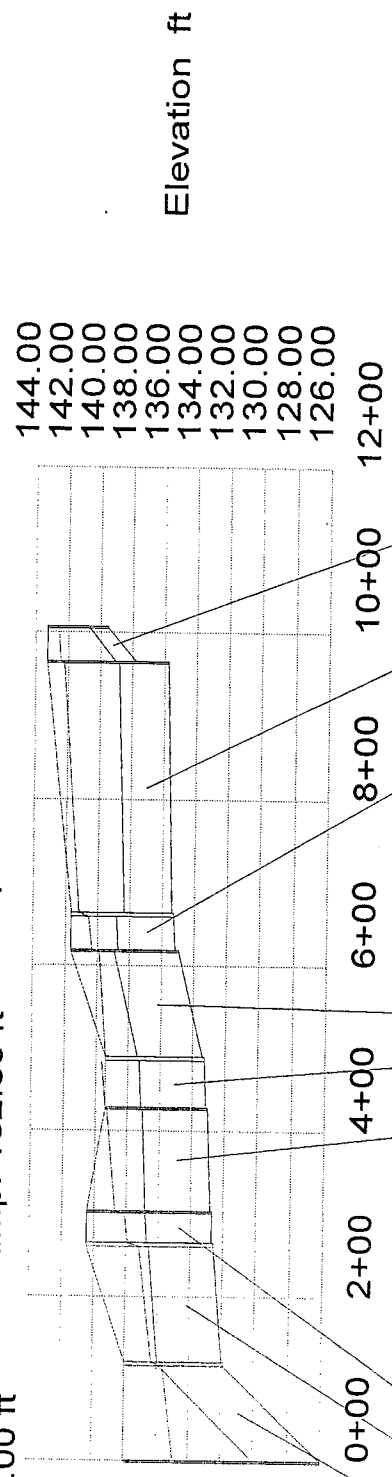

Elevation ft

Station ft

Pipe: P-17
Up Invert: 132.80 ft
Dh Invert: 132.70 ft
Length: 41.00 ft
Size: 48 inch

Pipe: P-18
Up Invert: 132.60 ft
Dh Invert: 132.00 ft
Length: 145.00 ft
Size: 48 inch

Pipe: P-19
Up Invert: 131.90 ft
Dh Invert: 126.00 ft
Length: 118.00 ft
Size: 48 inch

Pipe: P-14
Up Invert: 135.00 ft
Dh Invert: 133.40 ft
Length: 130.00 ft
Size: 48 inch

Pipe: P-15
Up Invert: 133.30 ft
Dh Invert: 133.20 ft
Length: 60.00 ft
Size: 48 inch

Pipe: P-16
Up Invert: 133.10 ft
Dh Invert: 132.90 ft
Length: 124.00 ft
Size: 48 inch

Pipe: P-11
Up Invert: 139.50 ft
Dh Invert: 137.80 ft
Length: 42.00 ft
Size: 15 inch

Pipe: P-12
Up Invert: 135.80 ft
Dh Invert: 135.40 ft
Length: 303.00 ft
Size: 36 inch

Pipe: P-13
Up Invert: 135.30 ft
Dh Invert: 135.20 ft
Length: 43.00 ft
Size: 42 inch

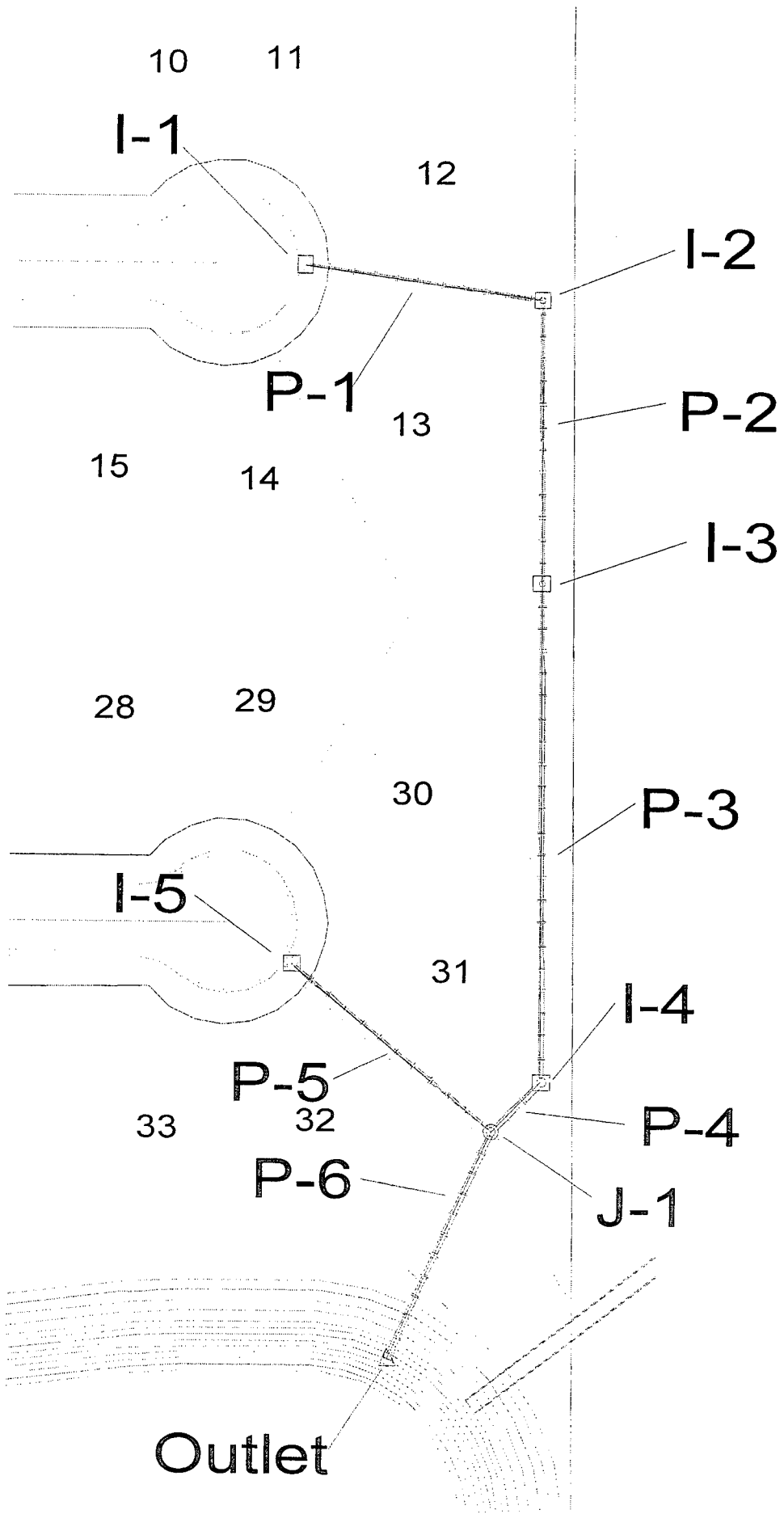

System Report

Pipe	Additional Flow (cfs)	Total Upstream Added (cfs)	Structure Discharge (cfs)	-Node- Upstream Downstream	-Section- Shape Size	Upstream Invert Elevation (ft)	Downstream Invert Elevation (ft)	-Ground- Upstream Downstream (ft)	-HGL- Upstream Downstream (ft)	-Slope- Energy Constructed (ft/ft)	-Section- Discharge Capacity (cfs)	Length (ft)	Average Velocity (ft/s)	Description
P-5	2.40	0.00	2.40	I-5	Circular 15 inch	137.00	134.20	140.60	137.62	0.020724	2.40	128.00	3.23	
P-1	3.90	0.00	3.90	I-1	Circular 18 inch	138.00	135.70	137.90	135.11	0.021875	9.55	118.00	3.73	
P-2	0.90	3.90	4.80	I-2	Circular 18 inch	135.60	135.10	139.00	136.71	0.019492	14.66	138.00	3.61	
P-3	3.20	4.80	8.00	I-3	Circular 24 inch	135.00	134.00	138.90	136.23	0.003623	6.32	243.00	4.48	
P-4	0.50	8.00	8.50	I-4	Circular 30 inch	133.50	133.30	137.90	135.16	0.004115	14.51	34.00	2.38	
P-6	N/A	10.90	10.90	J-1	Circular 30 inch	133.00	128.50	137.90	135.11	0.005882	31.46	122.00	2.37	
				Outlet				138.00	135.00	0.000701	78.77			

Inlet: I-1
 Rim: 141.00 ft
 Sump: 138.00 ft

Inlet: I-3
 Rim: 138.90 ft
 Sump: 135.00 ft

Junction: J-1
 Rim: 137.90 ft
 Sump: 133.00 ft

Inlet: I-2
 Rim: 139.00 ft
 Sump: 135.60 ft

Inlet: I-4
 Rim: 137.90 ft
 Sump: 133.50 ft

Outlet: Outlet
 Rim: 138.00 ft
 Sump: 128.50 ft

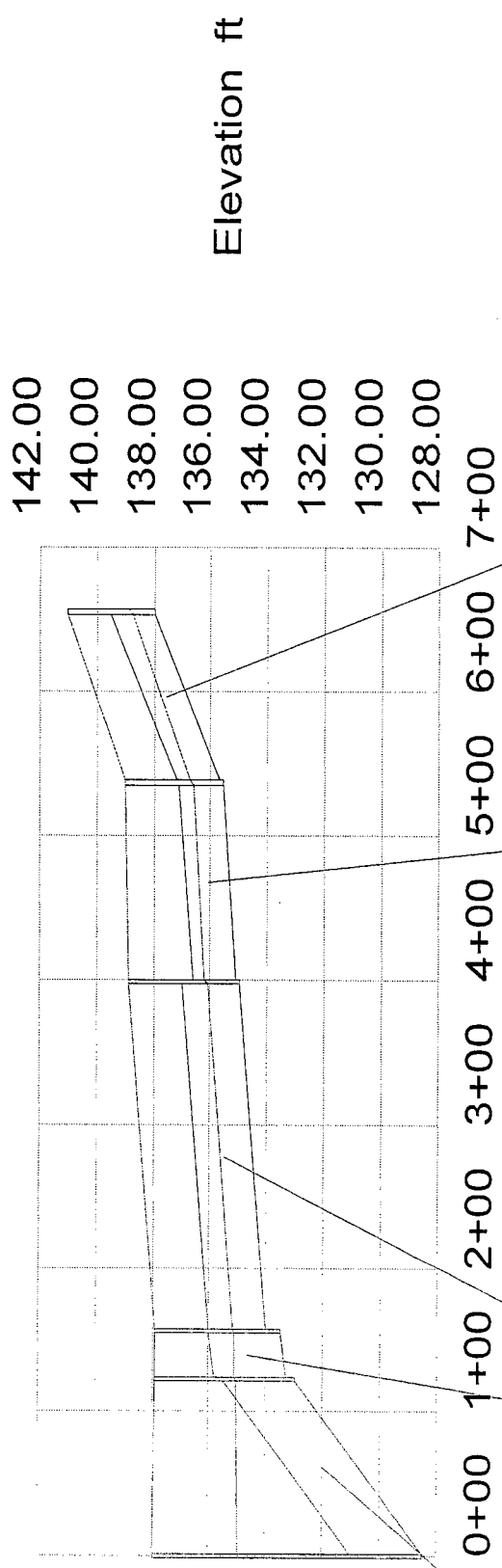

Pipe: P-1
 Up Invert: 138.00 ft
 Dn Invert: 135.70 ft
 Length: 118.00 ft
 Size: 18 inch

Pipe: P-2
 Up Invert: 135.60 ft
 Dn Invert: 135.10 ft
 Length: 138.00 ft
 Size: 18 inch

Pipe: P-3
 Up Invert: 135.00 ft
 Dn Invert: 134.00 ft
 Length: 243.00 ft
 Size: 24 inch

Pipe: P-4
 Up Invert: 133.50 ft
 Dn Invert: 133.30 ft
 Length: 34.00 ft
 Size: 30 inch

Pipe: P-6
 Up Invert: 133.00 ft
 Dn Invert: 128.50 ft
 Length: 122.00 ft
 Size: 30 inch

System Report

Pipe	Additional Flow (cfs)	Total Upstream Added (cfs)	Structure Discharge (cfs)	-Node- Upstream Downstream	-Section- Shape Size	Upstream Invert Elevation (ft)	Downstream Invert Elevation (ft)	-Ground- Upstream Downstream (ft)	-HGL- Upstream Downstream (ft)	-Slope- Energy Constructed (ft/ft)	-Section- Discharge Capacity (cfs)	Length (ft)	Average Velocity (ft/s)	Description
P-5	6.50	0.00	6.50	I-5	Circular	137.00	134.20	140.60	138.03	0.018504	6.50	128.00	5.66	
P-1	10.00	0.00	10.00	J-1 I-1	15 inch Circular	138.00	135.70	137.90 141.00	135.79 140.07	0.021875 0.009064	9.55 10.00	118.00	5.66	
P-2	0.90	10.00	10.90	I-2 I-3	18 inch Circular	135.60	135.10	139.00 139.00	139.00 139.61	0.019492 0.010769	14.66 10.90	138.00	6.17	
P-3	8.70	10.90	19.60	I-3 I-4	18 inch Circular	135.00	134.00	138.90 138.90	138.13 137.82	0.003623 0.007507	6.32 19.60	243.00	6.24	
P-4	1.30	19.60	20.90	I-4 J-1	24 inch Circular	133.50	133.30	137.90 137.90	136.00 135.85	0.004115 0.002343	14.51 20.90	34.00	4.31	
P-6	N/A	27.40	27.40	J-1 Outlet	30 inch Circular	133.00	128.50	137.90 138.00	135.79 135.54	0.005882 0.004463	31.46 27.40	122.00	5.58	
											78.77			

Junction: J-1
 Rim: 137.90 ft
 Sump: 133.00 ft

Inlet: I-3
 Rim: 138.90 ft
 Sump: 135.00 ft

Inlet: I-1
 Rim: 141.00 ft
 Sump: 138.00 ft

Inlet: I-4
 Rim: 137.90 ft
 Sump: 133.50 ft

Inlet: I-2
 Rim: 139.00 ft
 Sump: 135.60 ft

Outlet: Outlet
 Rim: 138.00 ft
 Sump: 128.50 ft

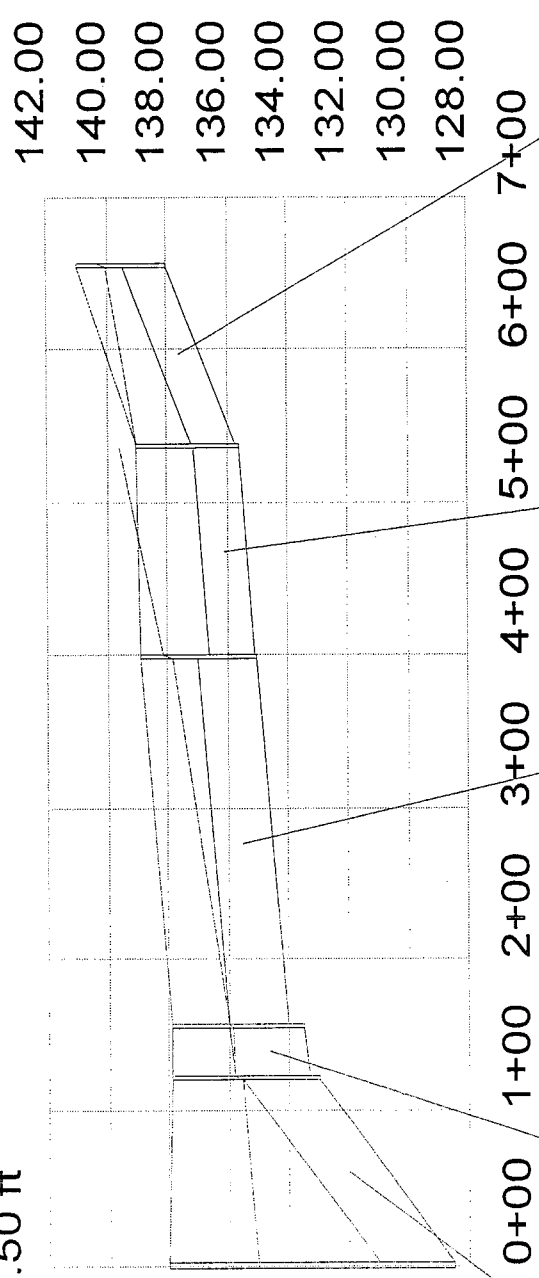

Station ft

Elevation ft

Pipe: P-4
 Up Invert: 133.50 ft
 Dn Invert: 133.30 ft
 Length: 34.00 ft
 Size: 30 inch

Pipe: P-3
 Up Invert: 135.00 ft
 Dn Invert: 134.00 ft
 Length: 243.00 ft
 Size: 24 inch

Pipe: P-2
 Up Invert: 135.60 ft
 Dn Invert: 135.10 ft
 Length: 138.00 ft
 Size: 18 inch

Pipe: P-1
 Up Invert: 138.00 ft
 Dn Invert: 135.70 ft
 Length: 118.00 ft
 Size: 18 inch

Pipe: P-6
 Up Invert: 133.00 ft
 Dn Invert: 128.50 ft
 Length: 122.00 ft
 Size: 30 inch

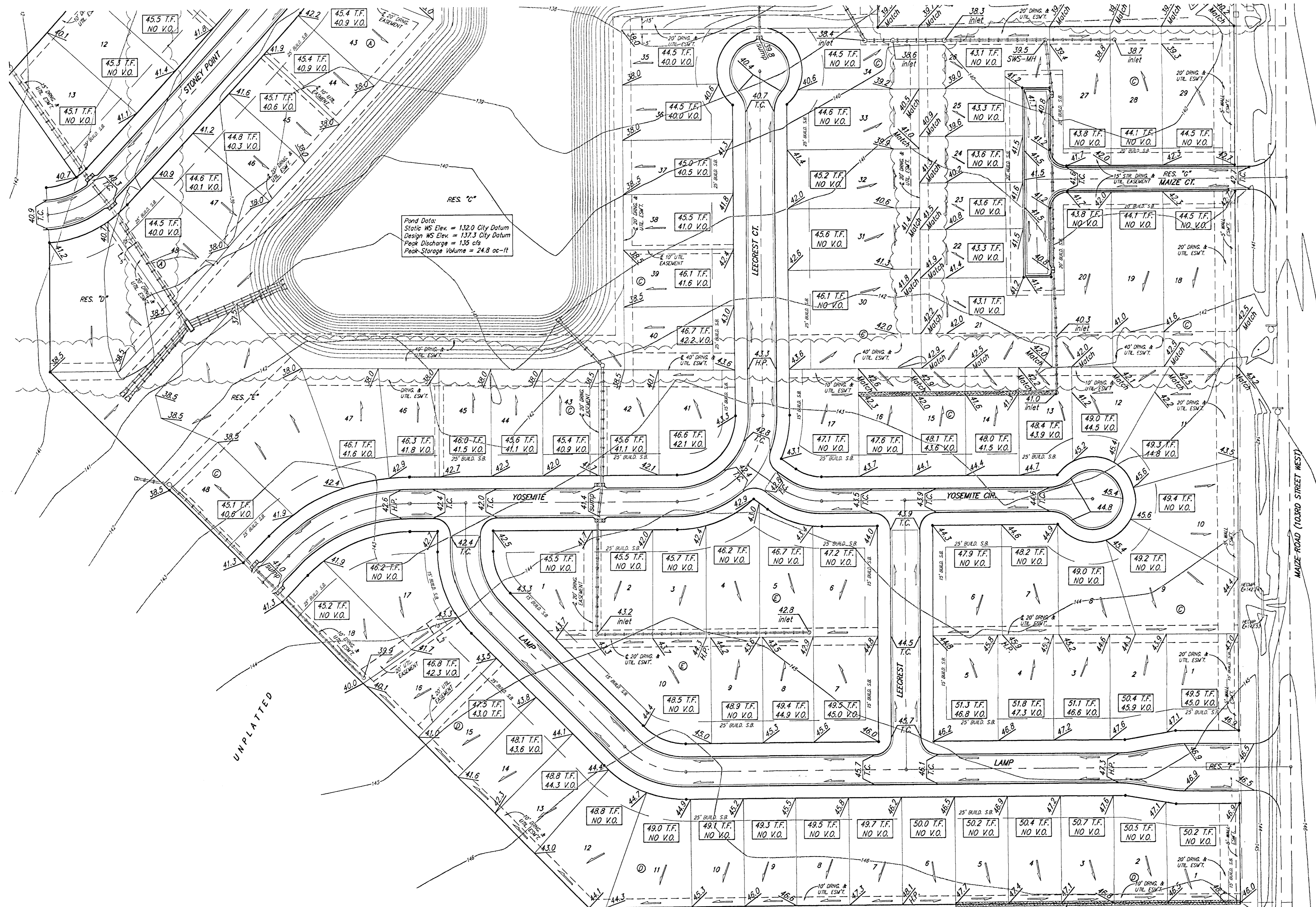

Pond Data:
 Static WS Elev. = 132.0 City Datum
 Design WS Elev. = 137.3 City Datum
 Peak Discharge = 136 cfs
 Peak Storage Volume = 24.8 ac-ft

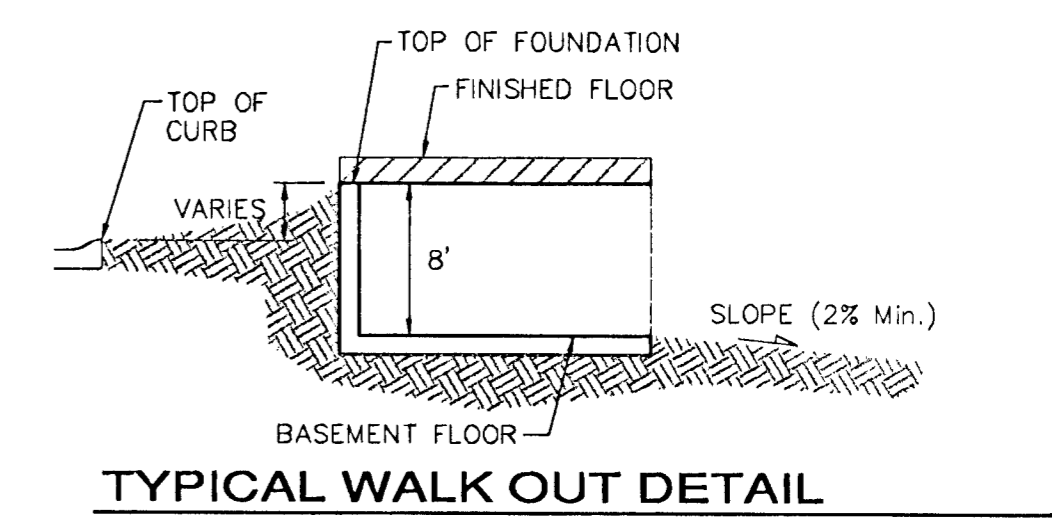
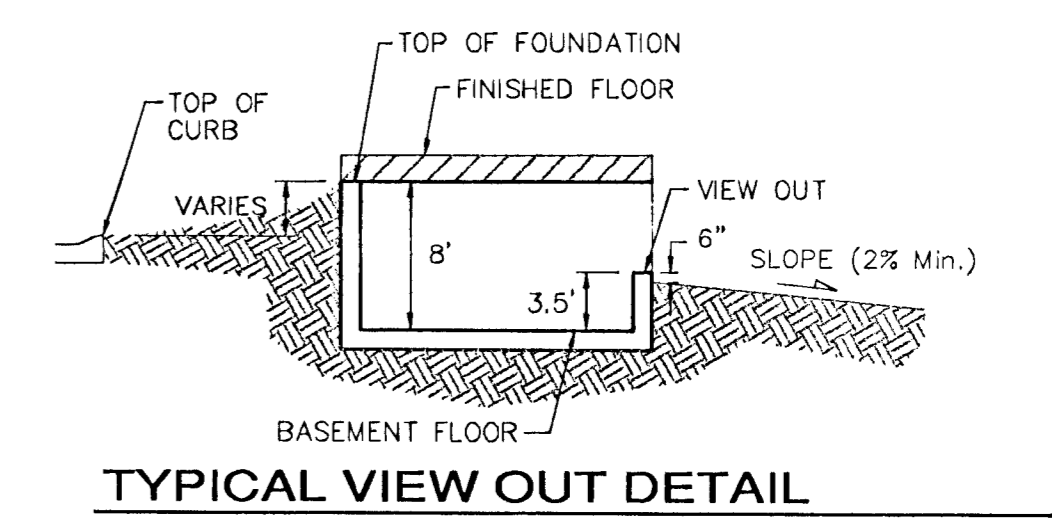
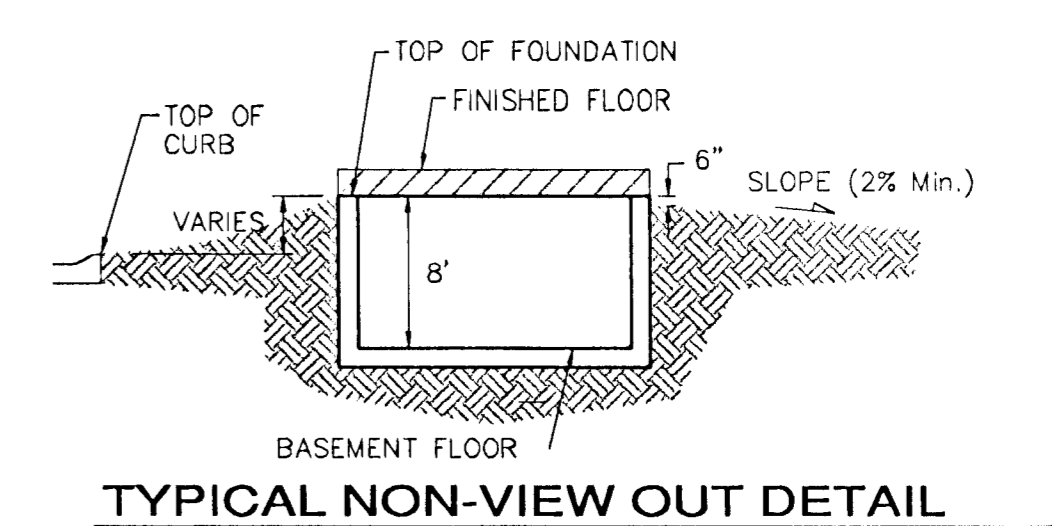
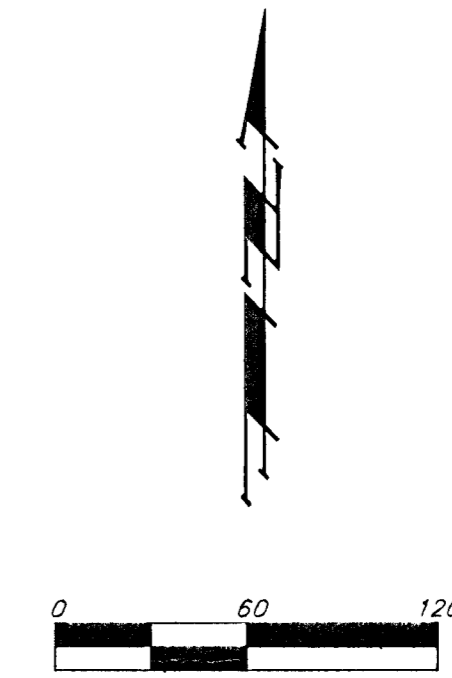

NOTES:
 Proposed Top of Foundation Elevations Are Shown On Plans. Contractor to Set Finished Floor Elevations.
 All Street Elevations Shown on Plans Are for Top of Curb (Full-Height).
 This Grading Plan is Designed with View-Outs. Elevations Shown at Rear of House (XX.X V.O.)
 Lot dimensions have been omitted on this plan, refer to the recorded plat for this information.

SOUTHERN RIDGE ADDITION
GRADING PLAN
 WICHITA, KANSAS

BAUGHMAN COMPANY P.A.
 ENGINEERING, SURVEYING, & PLANNING
 318-282-7271 • 315 ELLIS • WICHITA, KANSAS 67211

PROJECT NUMBER					SHEET
DESIGN	DRAWN	APPROVED	DATE	SCALE	2
BLG	BLG	BLG	14OCT02	NOTED	2

PHASE1 GRADING.DWG

PRELIMINARY PLAN
NOT FOR CONSTRUCTION

DRAINAGE CONCEPT SOUTHERN RIDGE ADDITION WICHITA, SEDGWICK COUNTY, KANSAS

BENCHMARK:
City of Wichita Benchmark Disc -
SW Corner of the intersection of
Pawnee & Mesa Sts.
44' South of centerline
49' West of centerline
12' East of face
65' SW of Sec. corner from
Elev. = 1322.0 City Datum
1322.52 NGVD29

CONTOUR INTERVAL = 1 FT.
DATE OF TOPOGRAPHY: 1 JUNE 2002
DATE OF PREPARATION: 30 SEPT 2002

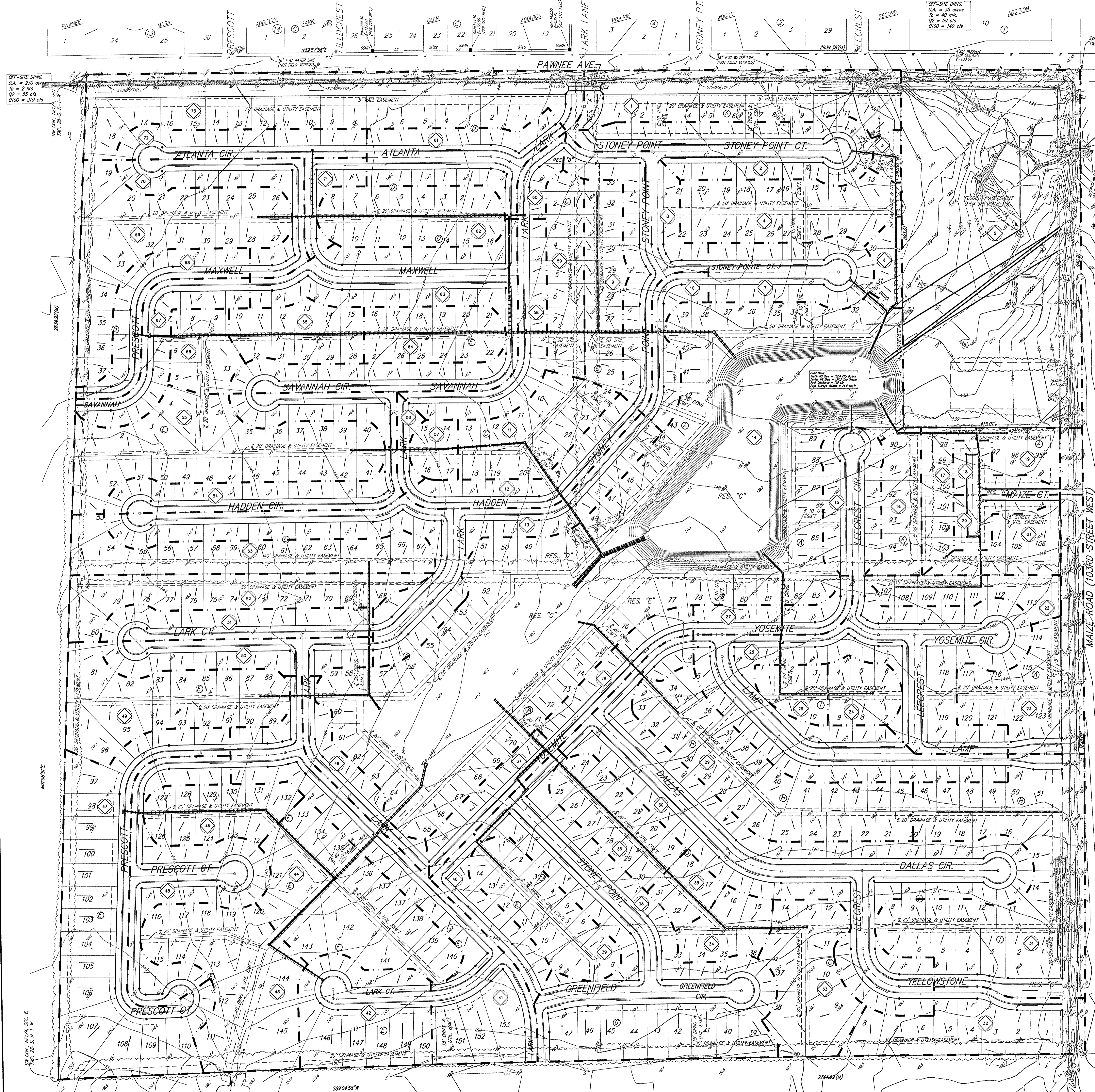

EXISTING RCBC
DISC 974
INLET CONTROL
CAPACITY = 850 CFS

Existing Conditions
D.A. = 410 acres
Q2 = 260 cfs
Q100 = 350 cfs

Developed Cond.
D.A. = 410 acres
Q2 = 180 cfs
Q100 = 400 cfs

DRAINAGE BASIN DATA

Basin ID	Basin Area (acres)	Rational Method Coefficients	Peak Flowrate (cfs)
		2-yr	100-yr
1	2.7	0.42 0.44	0.59 4.3
2	2.4	0.42 0.44	0.59 3.9
3	0.2	0.42 0.44	0.59 0.3
4	2.1	0.42 0.44	0.59 3.4
5	10.5	0.42 0.44	0.59 17
6	0.4	0.42 0.44	0.59 0.8
7	1.6	0.42 0.44	0.59 3.4
8	2.1	0.42 0.44	0.59 2.6
9	1.3	0.42 0.44	0.59 2.1
10	0.7	0.42 0.44	0.59 1.1
11	1.6	0.42 0.44	0.59 2.6
12	1.2	0.42 0.44	0.59 1.9
13	3.9	0.42 0.44	0.59 6
14	18.7	0.36 0.56	0.68 39
15	1.3	0.42 0.44	0.59 2.1
16	1.0	0.42 0.44	0.59 1.6
17	0.8	0.42 0.44	0.59 1.3
18	0.5	0.42 0.44	0.59 0.8
19	0.9	0.42 0.44	0.59 1.0
20	0.5	0.42 0.44	0.59 0.8
21	0.9	0.42 0.44	0.59 1.4
22	1.0	0.42 0.44	0.59 1.6
23	2.3	0.42 0.44	0.59 3.7
24	0.7	0.42 0.44	0.59 1.1
25	0.8	0.42 0.44	0.59 1.0
26	6.0	0.42 0.44	0.59 9.7
27	0.8	0.42 0.44	0.59 1.3
28	0.9	0.42 0.44	0.59 1.4
29	3.2	0.42 0.44	0.59 5.1
30	6.3	0.42 0.44	0.59 10
31	5.2	0.42 0.44	0.59 8.4
32	2.0	0.42 0.44	0.59 3.2
33	1.9	0.42 0.44	0.59 3.1
34	0.8	0.42 0.44	0.59 1.3
35	0.8	0.42 0.44	0.59 1.2
36	1.4	0.42 0.44	0.59 3.1
37	0.8	0.42 0.44	0.59 1.3
38	5.7	0.42 0.44	0.59 9.2
39	1.6	0.42 0.44	0.59 2.6
40	0.8	0.42 0.44	0.59 1.3
41	3.5	0.42 0.44	0.59 5.8
42	2.1	0.42 0.44	0.59 3.4
43	2.9	0.42 0.44	0.59 4.7
44	3.2	0.42 0.44	0.59 5.4
45	2.5	0.42 0.44	0.59 4.0
46	1.3	0.42 0.44	0.59 2.1
47	4.9	0.42 0.44	0.59 7.9
48	0.9	0.42 0.44	0.59 1.4
49	2.5	0.42 0.44	0.59 4.0
50	1.3	0.42 0.44	0.59 2.1
51	1.3	0.42 0.44	0.59 2.1
52	2.1	0.42 0.44	0.59 3.4
53	2.1	0.42 0.44	0.59 3.4
54	2.3	0.42 0.44	0.59 3.7
55	3.5	0.42 0.44	0.59 5.8
56	0.3	0.42 0.44	0.59 0.5
57	0.4	0.42 0.44	0.59 0.6
58	1.3	0.42 0.44	0.59 2.1
59	1.2	0.42 0.44	0.59 1.9
60	0.4	0.42 0.44	0.59 0.6
61	1.7	0.42 0.44	0.59 3.4
62	1.7	0.42 0.44	0.59 3.4
63	3.8	0.42 0.44	0.59 6.1
64	1.3	0.42 0.44	0.59 2.1
65	1.2	0.42 0.44	0.59 1.9
66	0.9	0.42 0.44	0.59 1.4
67	1.2	0.42 0.44	0.59 1.9

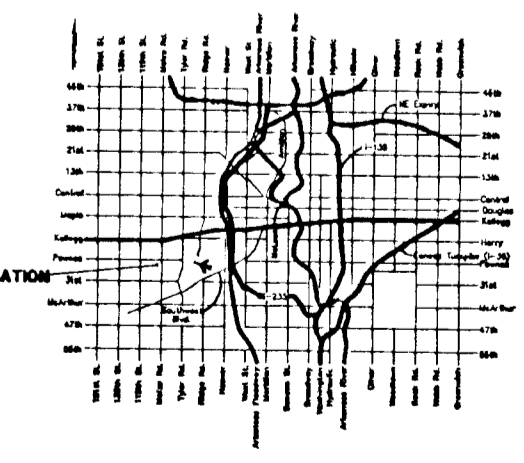

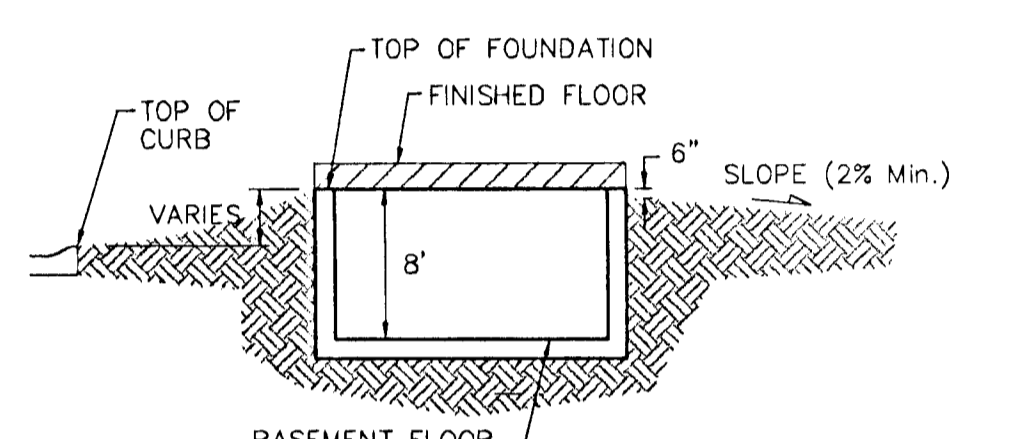
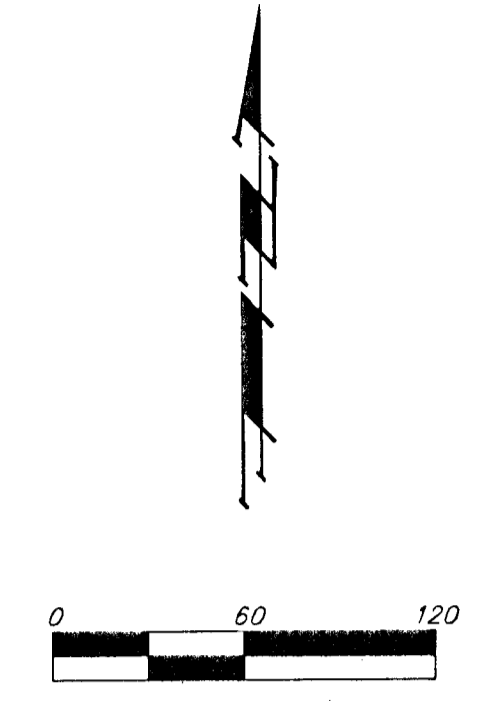
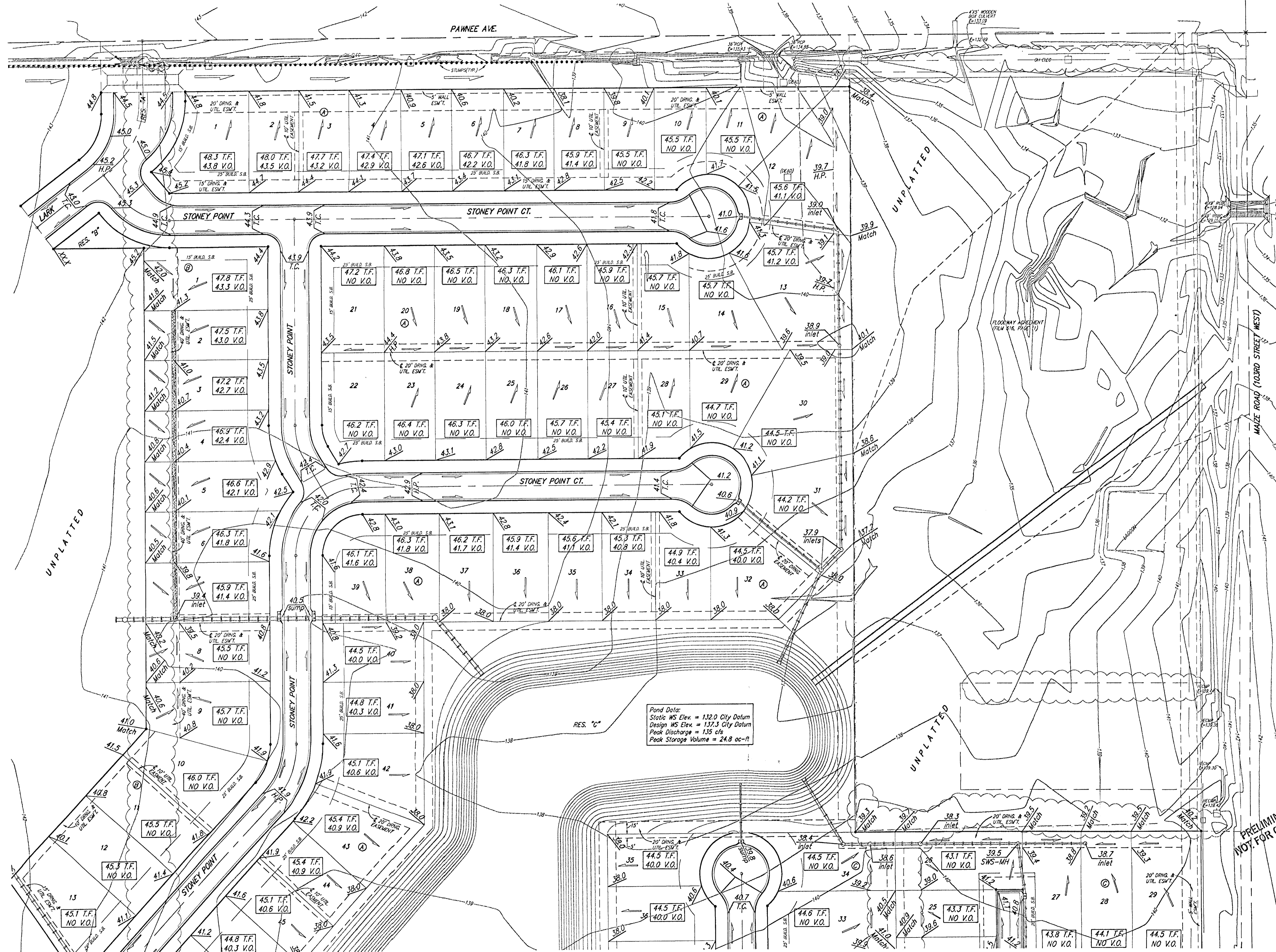

TYPICAL NON-VIEW OUT DETAIL
 NO SCALE

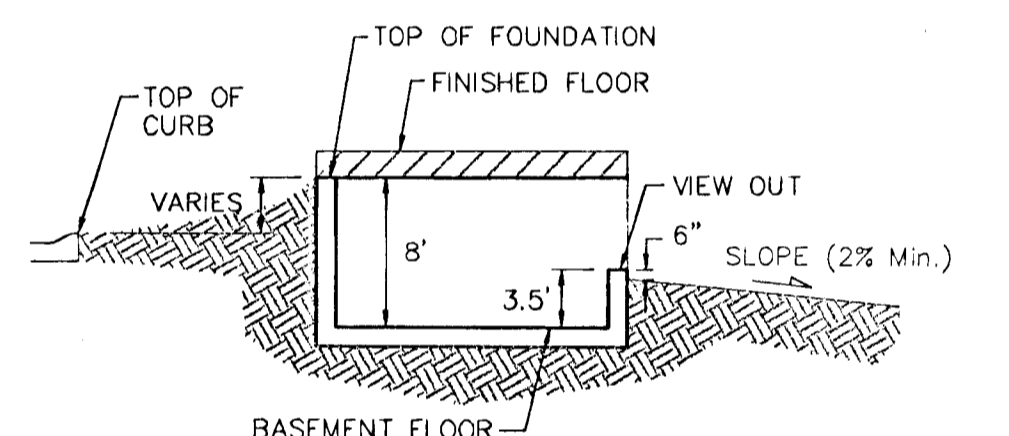

TYPICAL VIEW OUT DETAIL
 NO SCALE

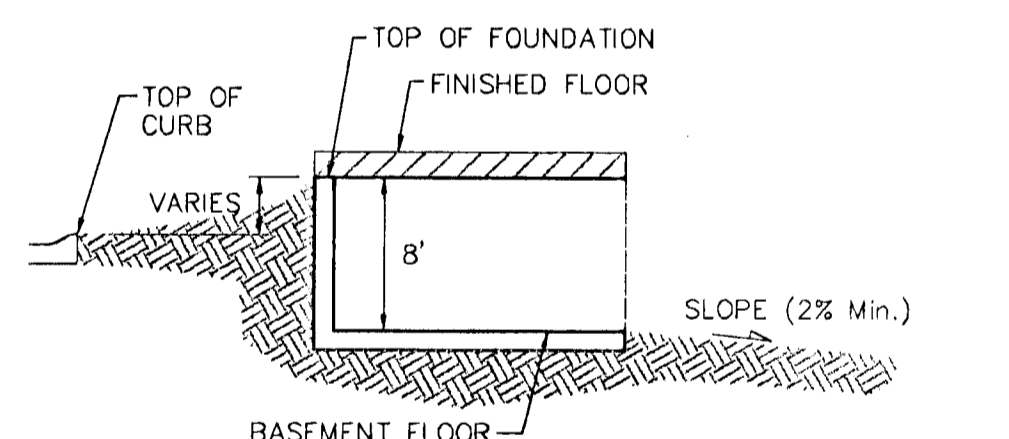

TYPICAL WALK OUT DETAIL
 NO SCALE

NOTES:
 Proposed Top of Foundation Elevations Are Shown On Plans. Contractor to Set Finished Floor Elevations.
 All Street Elevations Shown on Plans Are for Top of Curb (Full-Height).
 This Grading Plan is Designed with View-Outs. Elevations Shown at Rear of House (XX.X V.O.).
 Lot dimensions have been omitted on this plan, refer to the recorded plat for this information.

SOUTHERN RIDGE ADDITION
GRADING PLAN
 WICHITA, KANSAS

BAUGHMAN COMPANY P.A.
 ENGINEERING, SURVEYING, & PLANNING
 318-262-7271 • 315 ELLIS • WICHITA, KANSAS 67211

PROJECT NUMBER				SHEET	
				1	
DESIGN	DRAWN	APPROVED	DATE	SCALE	NOTED
BLG	BLG		14OCT02	NOTED	

PRELIMINARY PLAN
 NOT FOR CONSTRUCTION