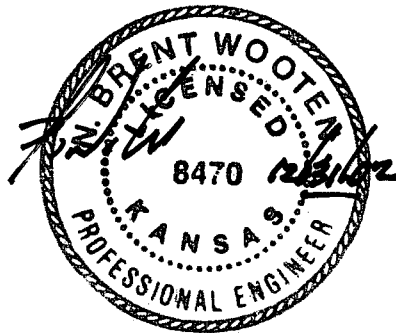

TABLE OF CONTENTS

Narrative.....1
Copy of Letter of Map Amendment.....2
Location Map.....5
USGS Quadrangle Map.....6
SCS Ariel Photograph.....7
Appendices:
 StormCad Hydraulic Calculations
 Drainage Plan Sheet
 Sub-Division Grading Plan



NARRATIVE

This report provides information and supporting documentation to support the "Drainage Plan" for the property located in the Southeast Quarter of Section 12, T-26-S, R-1-W in Sedgwick County, Kansas.

The "Drainage Plan" being submitted herein is intended to serve as a guide for the design of streets and storm water sewer improvements to the proposed development. Modifications to structures, pipes, etc. may be made as necessary during the final design in order to obtain the most economical design and construction possible.

Storm water sewer systems within this proposed development have been designed to convey the 2-yr rainfall event. Calculations have also been performed to check the design during the 100-yr event. A sub-division grading plan has been prepared in conjunction with the storm water sewer design. This grading plan allows for emergency outflow points during major rainfall events.

A Letter of Map Amendment (LOMA) has also affected this property. The LOMA (case# 01-07-115A, effective March 23, 2001) was prepared by Moehring & Associates and submitted to FEMA by Sedgwick County Public Works. The determination was that the property has been removed from the Special Flood Hazard Area (SFHA) except that portion as described in a metes and bounds description. This description, on file with the Sedgwick County Register of Deeds (film 2039, page 1026) isolates the area that remains in the SFHA, and has been contained within Reserve "A" of the proposed development.

Minimum Pads (for Lowest Openings), have been established according to the Base Flood Elevations (B.F.E.'s) reported in the above mentioned LOMA. The Minimum Pads for all lots abutting Reserve "A" have been established at an elevation of one foot greater than the highest B.F.E. identified in the LOMA.



Federal Emergency Management Agency

Washington, D.C. 20472

March 23, 2001

Mr. James Catron
6545 Bella Road
Wichita, KS 67204

Case No.: 01-07-115A
Community: Sedgwick County, Kansas
(Unincorporated Areas)
Community No.: 200321

Dear Mr. Catron:

This is in reference to a request that the Federal Emergency Management Agency (FEMA) determine if property is located within an identified Special Flood Hazard Area, the area that would be inundated by the flood having a 1-percent chance of being equaled or exceeded in any given year (base flood), on the effective National Flood Insurance Program (NFIP) map. Using the information submitted and the effective NFIP map, our determination is shown on the attached Letter of Map Amendment (LOMA) Determination Document. This determination document provides additional information regarding the effective NFIP map, the legal description of the property, and our determination.

Additional documents are enclosed which provide information regarding the subject property and LOMAs. Please see the List of Enclosures below to determine which documents are enclosed. If you have any questions about this letter or any of the enclosures, please contact the FEMA Map Assistance Center toll free at 1-877-FEMA MAP (1-877-336-2627) or by letter addressed to the FEMA LOMA DEPOT, PBS&J, 12101 Indian Creek Court, Beltsville, Maryland 20705.

Sincerely,

Matthew B. Miller

Matthew B. Miller, P.E., Chief
Hazards Study Branch
Mitigation Directorate

List of Enclosures

- LOMA Determination Document, Pages 1 & 2

cc: Community Map Repository



Federal Emergency Management Agency

Washington, D.C. 20472

LETTER OF MAP AMENDMENT DETERMINATION DOCUMENT (REMOVAL)

COMMUNITY AND MAP PANEL INFORMATION		LEGAL PROPERTY DESCRIPTION
COMMUNITY	Sedgwick County, Kansas (Unincorporated Areas)	A portion of Section 12, Township 26 South, Range 1 West of the 6 th Principal Meridian, as described in Warranty Deed, Document No. 1881109, recorded on Film 2039, Page 1026, filed on April 24, 2000, by the Register of Deeds, Sedgwick County, Kansas; the portion of land to remain in the SFHA is more particularly described by the following metes and bounds: COMMENCING at the Southeast corner of the Southeast quarter of Section 12, Township 26 South, Range 1 West of the 6 th Principal Meridian, Sedgwick County, Kansas; thence North along the East line of said Section 12, and with an assumed bearing of N00°59'04"W, a distance of 1650.14 feet to the Northeast corner of the East 40.0 acres of the South 100 acres of the Southeast quarter of said Section 12; thence West along the North line of
	COMMUNITY NO: 200321	
MAP PANEL AFFECTED	NUMBER: 2003210125A	
	NAME: Sedgwick County, Kansas (Unincorporated Areas)	
	DATE: June 3, 1986	
FLOODING SOURCE: Little Arkansas River		APPROXIMATE LATITUDE & LONGITUDE: 37.797, -97.373 SOURCE OF LATITUDE & LONGITUDE: MAPBLAST! DATUM: NAD83

DETERMINATION

LOT	BLOCK/SECTION	SUBDIVISION	STREET ADDRESS	OUTCOME WHAT IS REMOVED FROM THE SFHA	NEW FLOOD ZONE	1% ANNUAL CHANCE FLOOD ELEVATION (NGVD29)	LOWEST ADJACENT GRADE ELEVATION (NGVD29)	LOWEST FLOOR ELEVATION (NGVD29)	LOWEST LOT ELEVATION (NGVD29)
-	-	-	-	Portion of Property	C	-	-	-	-

Special Flood Hazard Area (SFHA) - The SFHA is an area that would be inundated by the flood having a 1-percent chance of being equaled or exceeded in any given year (base flood).

ADDITIONAL CONSIDERATIONS (if the appropriate box is checked, please refer to the appropriate section an Attachment 1)

- | | |
|---|--|
| <input checked="" type="checkbox"/> 1. PROPERTY DESCRIPTION (CONTINUED) | <input checked="" type="checkbox"/> 6. STUDY UNDERWAY |
| <input type="checkbox"/> 2. DETERMINATION TABLE (CONTINUED) | <input type="checkbox"/> 7. FILL RECOMMENDATION |
| <input type="checkbox"/> 3. PORTIONS REMAIN IN THE FLOODWAY | <input checked="" type="checkbox"/> 8. PORTIONS REMAIN IN THE SFHA |
| <input type="checkbox"/> 4. INADVERTENT INCLUSION IN THE FLOODWAY | <input checked="" type="checkbox"/> 9. VARIABLE BASE FLOOD ELEVATION |
| <input checked="" type="checkbox"/> 5. ZONE A | |

This document provides the Federal Emergency Management Agency's determination regarding a request for a Letter of Map Amendment for the property described above. Using the information submitted and the effective National Flood Insurance Program (NFIP) map, we determined that a portion of the property is not located in the SFHA, an area inundated by the flood having a 1-percent chance of being equaled or exceeded in any given year (base flood). This document amends the effective NFIP map to remove a portion of the property from the SFHA; therefore, the federal mandatory flood insurance requirement does not apply. However, the lender has the option to continue the flood insurance requirement to protect its financial risk on the loan. A Preferred Risk Policy (PRP) is available for buildings located outside the SFHA. Information about the PRP and how one can apply is enclosed.

This determination is based on the flood data presently available. The enclosed documents provide additional information regarding this determination. If you have any questions about this document, please contact the FEMA Map Assistance Center toll free at 1-877-FEMA MAP (1-877-336-2627) or by letter addressed to the FEMA LOMA DEPOT, 12101 Indian Creek Court, Beltsville, MD 20705.

Matthew B. Miller

Matthew B. Miller, P.E., Chief
Hazards Study Branch
Mitigation Directorate



Federal Emergency Management Agency

Washington, D.C. 20472

LETTER OF MAP AMENDMENT DETERMINATION DOCUMENT (REMOVAL) ATTACHMENT 1 (ADDITIONAL CONSIDERATIONS)

1. PROPERTY DESCRIPTION (CONTINUED)

said South 100 acres, N90°00'00"W, a distance of 316.87 feet to the POINT OF BEGINNING, said point being on the centerline of the Little Arkansas River; thence S08°54'34"E, along said centerline a distance of 480.04 feet; thence S24°45'35"E, along said centerline, a distance of 363.87 feet; thence S66°16'08"E, along said centerline, a distance of 4.35 feet; to a point in the West line of Meridian Avenue right-of-way; thence S00°59'04"E, along said right-of-way, a distance of 233.58 feet; thence S76°57'52"W, a distance of 48.97 feet; thence N77°42'44"W, a distance of 123.00 feet; thence N63°28'08"W, a distance of 67.27 feet; thence N26°20'10"W, a distance of 44.78 feet; thence N03°35'47"E, a distance of 89.50 feet; thence N17°29'55"W, a distance of 485.84 feet; thence N09°19'09"W, a distance of 215.21 feet; thence N42°07'19"W, a distance of 255.63 feet to a point on the North line of said South 100 acres; thence S90°00'00"E, a distance of 360.00 feet to the POINT OF BEGINNING.

5. ZONE A

The NFIP map affecting this property depicts the SFHA (Zone A) determined using the flood data available, but without performing a detailed engineering analysis or establishing base flood elevations. Determinations based on these flood data are approximate and subject to change.

6. STUDY UNDERWAY

This determination is based on the flood data presently available. However, the Federal Emergency Management Agency is currently revising the National Flood Insurance Program (NFIP) map for Sedgwick County. New flood data could be generated that may affect this property. When the new NFIP map is issued it will supersede this determination. The Federal requirement for the purchase of flood insurance will then be based on the new effective NFIP map.

8. PORTIONS OF THE PROPERTY REMAIN IN THE SFHA

The Determination Document has removed the subject of the determination from the Special Flood Hazard Area (SFHA). However, portions of the property may remain in the SFHA. Therefore, any future construction or substantial improvement on the property remains subject to Federal, State, and local regulations for floodplain management.

9. VARIABLE BASE FLOOD ELEVATION

The BFE ranges from 1332.6 feet at the upstream edge of the lot, where the ground elevation is 1332.6 feet, to 3331.1 feet at the downstream edge of the lot, where the ground elevation is 1332.0 feet.

This attachment provides additional information regarding this request. If you have any questions about this attachment, please contact the Federal Emergency Management Agency Map Assistance Center toll free at 1-877-FEMA MAP (1-877-338-2627) or by letter addressed to the FEMA LOMA DEPOT, PBS&J, 12101 Indian Creek Court, Beltsville, MD 20705.

Matthew B. Miller

Matthew B. Miller, P.E., Chief
Hazards Study Branch
Mitigation Directorate

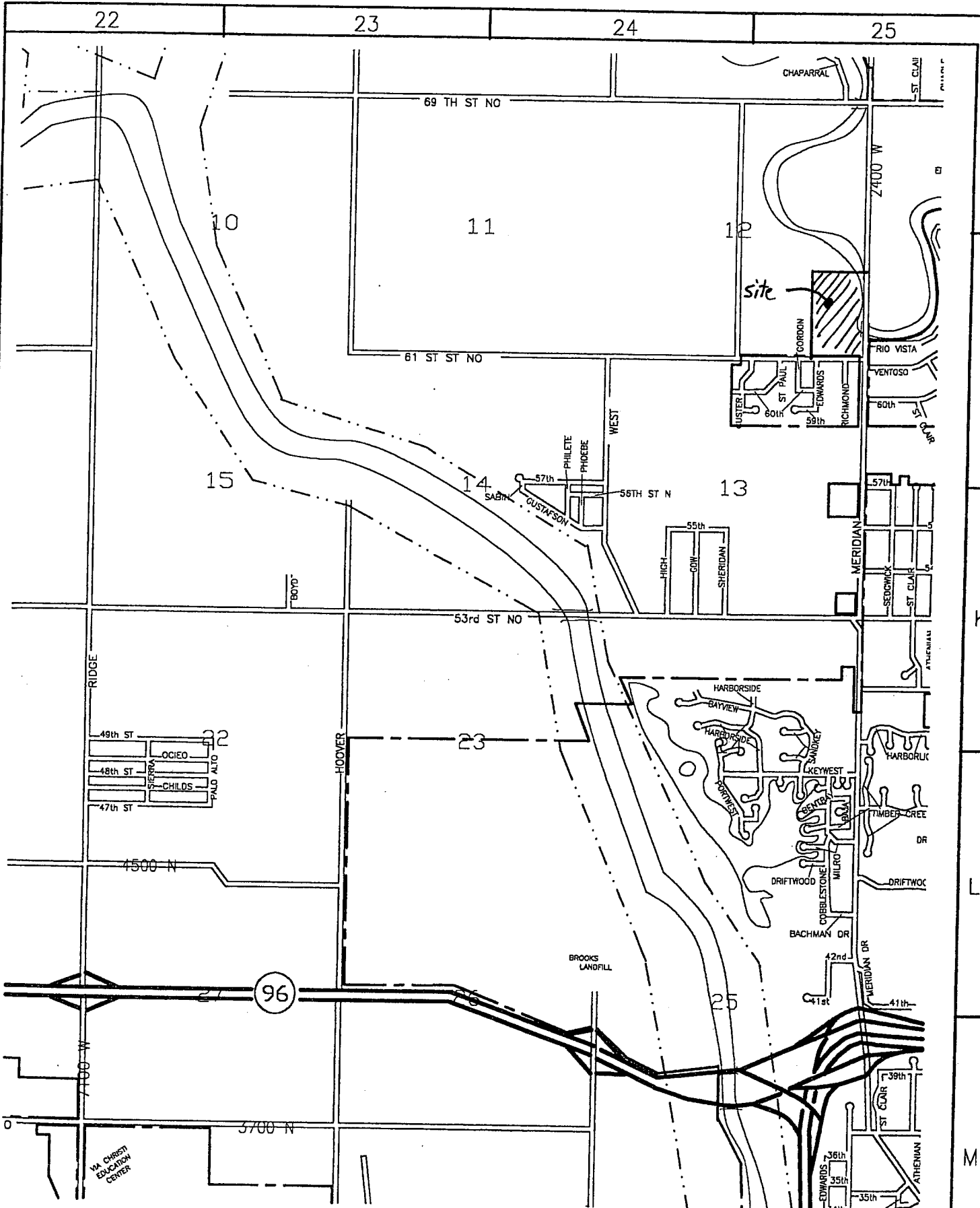

(See Page 21)

© Kansas Blue Print Co., Inc.

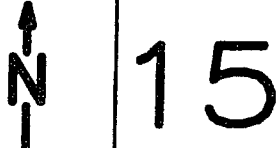

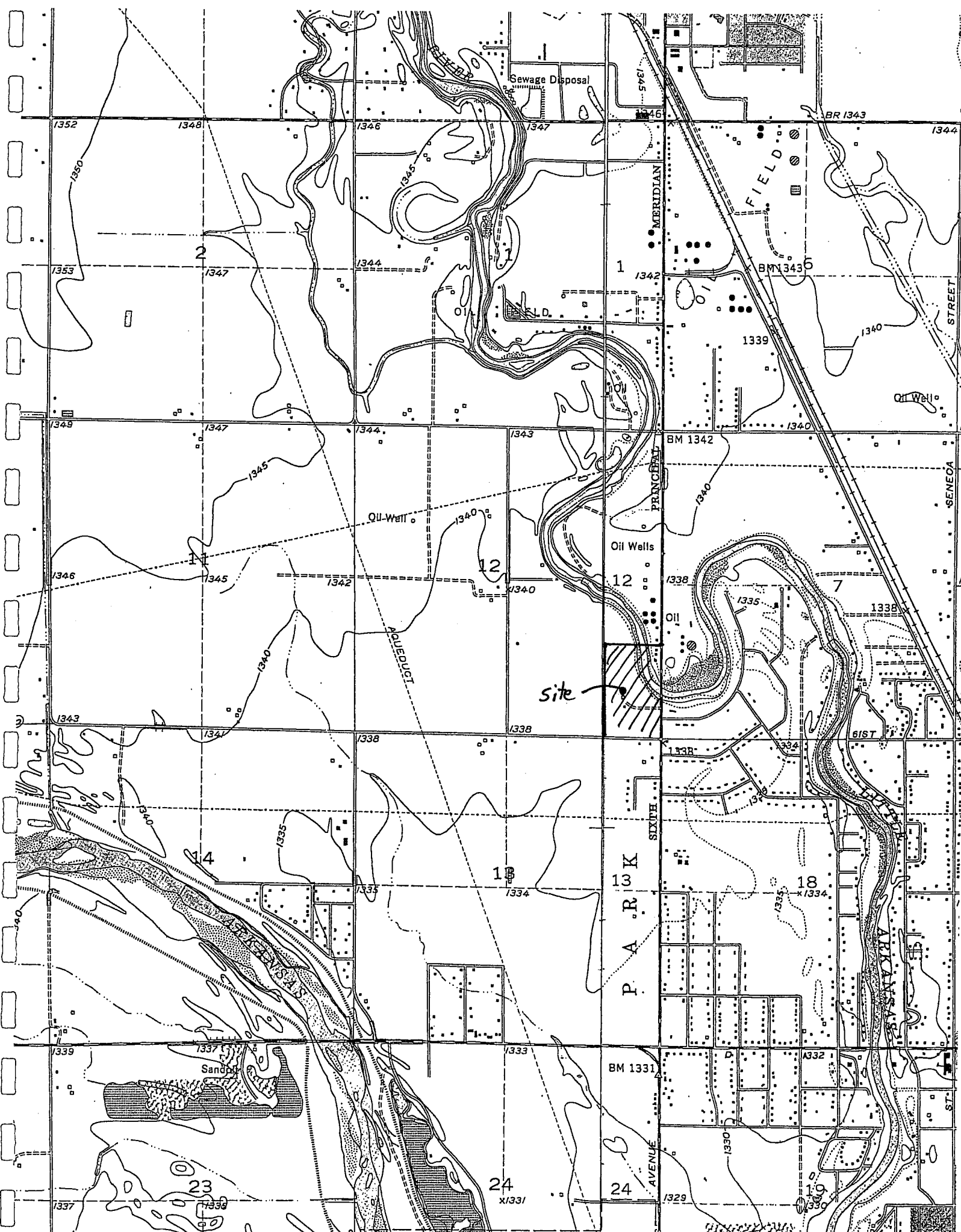

Sewage Disposal

MERIDIAN

FIELD

PRINCIPAL

PARK

ARIZONA

SANDPIT

site

2

1

12

7

14

13

18

23

24

19

1352

1348

1346

1347

1344

1353

1347

1344

1342

BM 1343

1349

1347

1344

1343

BM 1342

1346

1345

1342

1340

1343

1341

1338

1338

1340

1340

1335

1334

1339

1337

1333

1333

BM 1331

1331

1337

1333

1331

1329

1330

STREET

SENECA

SIXTH

AVENUE

ST.

BR 1343

61ST

X1331

2 320 000 FEET

1 R. 1 W. | R. 1 E.

420 000 FEET

T. 26 S.

(Joins sheet 18)

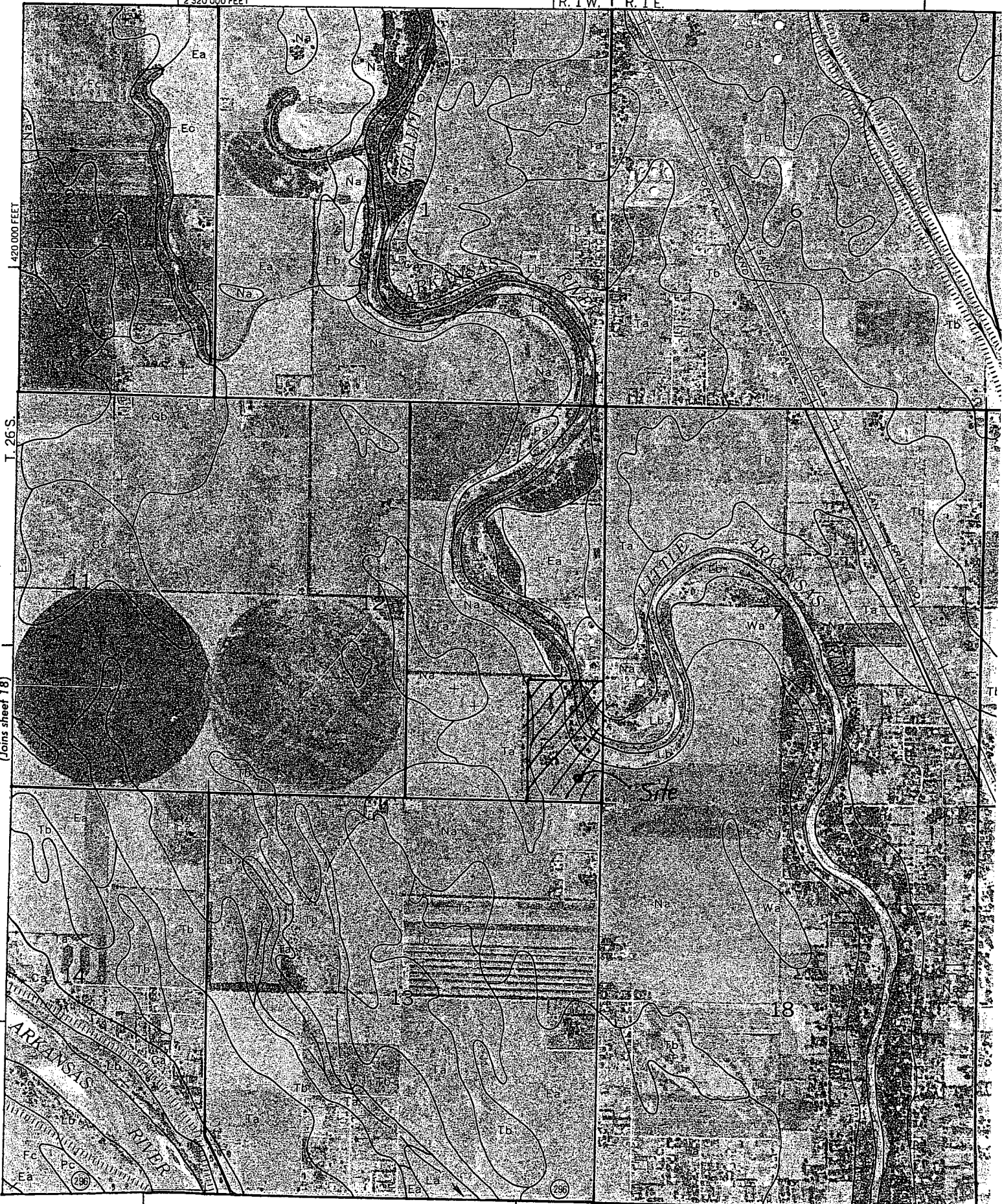

StormCad Hydraulic Calculations

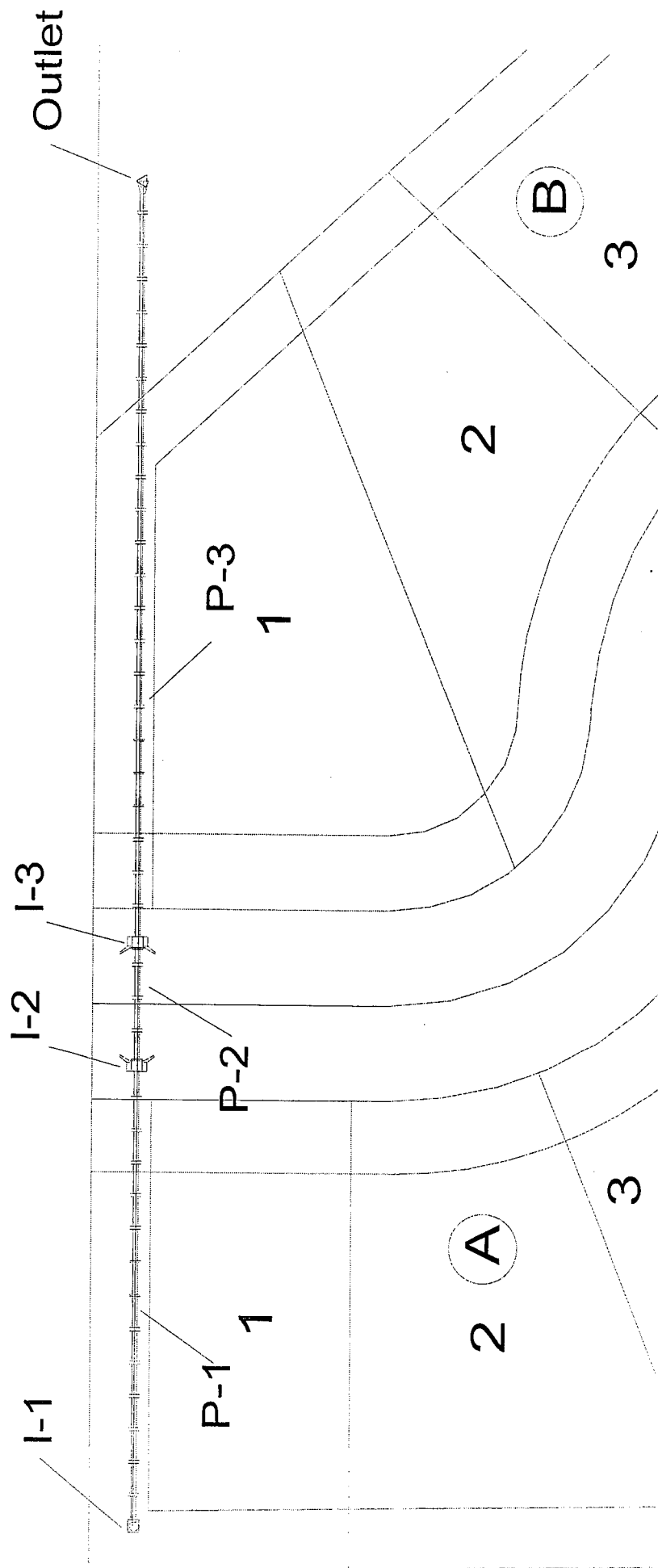

System Report

Pipe	Additional Flow (cfs)	Total Upstream Added (cfs)	Structure Discharge (cfs)	-Node- Upstream Downstream	-Section- Shape Size	Upstream Invert Elevation (ft)	Downstream Invert Elevation (ft)	-Ground- Upstream Downstream (ft)	-HGL- Upstream Downstream (ft)	-Slope- Energy Constructed (ft/ft)	-Section- Discharge Capacity (cfs)	Length (ft)	Average Velocity (ft/s)	Description
P-1	2.20	0.00	2.20	I-1	Circular	143.90	143.30	147.60	146.81	0.001160	2.20	154.00	1.79	
P-2	2.70	2.20	4.90	I-2 I-3	15 inch Circular	142.90	142.70	147.40	146.58	0.003896 0.002176	4.03 4.90	41.00	2.77	
P-3	2.20	4.90	7.10	I-3 Outlet	18 inch Circular	142.60	141.60	147.40	146.49	0.004878 0.004569	7.34 7.10	254.00	4.02	

Inlet: I-2
 Rim: 147.40 ft
 Sump: 142.90 ft

Inlet: I-1
 Rim: 147.60 ft
 Sump: 143.90 ft

Inlet: I-3
 Rim: 147.40 ft
 Sump: 142.60 ft

Outlet: Outlet
 Rim: 144.00 ft
 Sump: 141.60 ft

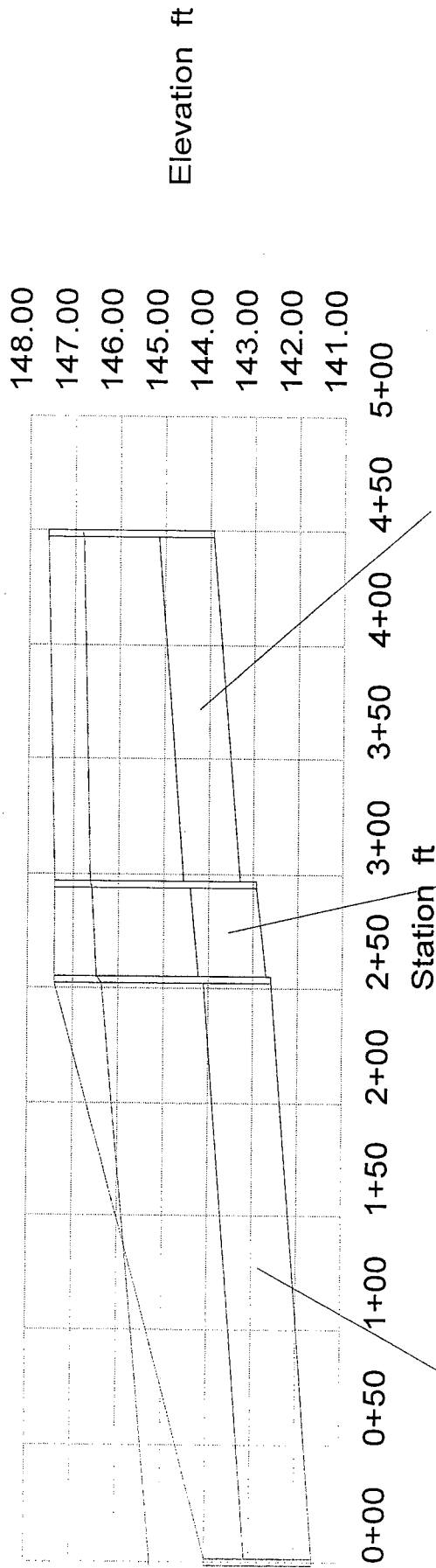

Pipe: P-3
 Up Invert: 142.60 ft
 Dn Invert: 141.60 ft
 Length: 254.00 ft
 Size: 18 inch

Pipe: P-2
 Up Invert: 142.90 ft
 Dn Invert: 142.70 ft
 Length: 41.00 ft
 Size: 18 inch

Pipe: P-1
 Up Invert: 143.90 ft
 Dn Invert: 143.30 ft
 Length: 154.00 ft
 Size: 15 inch

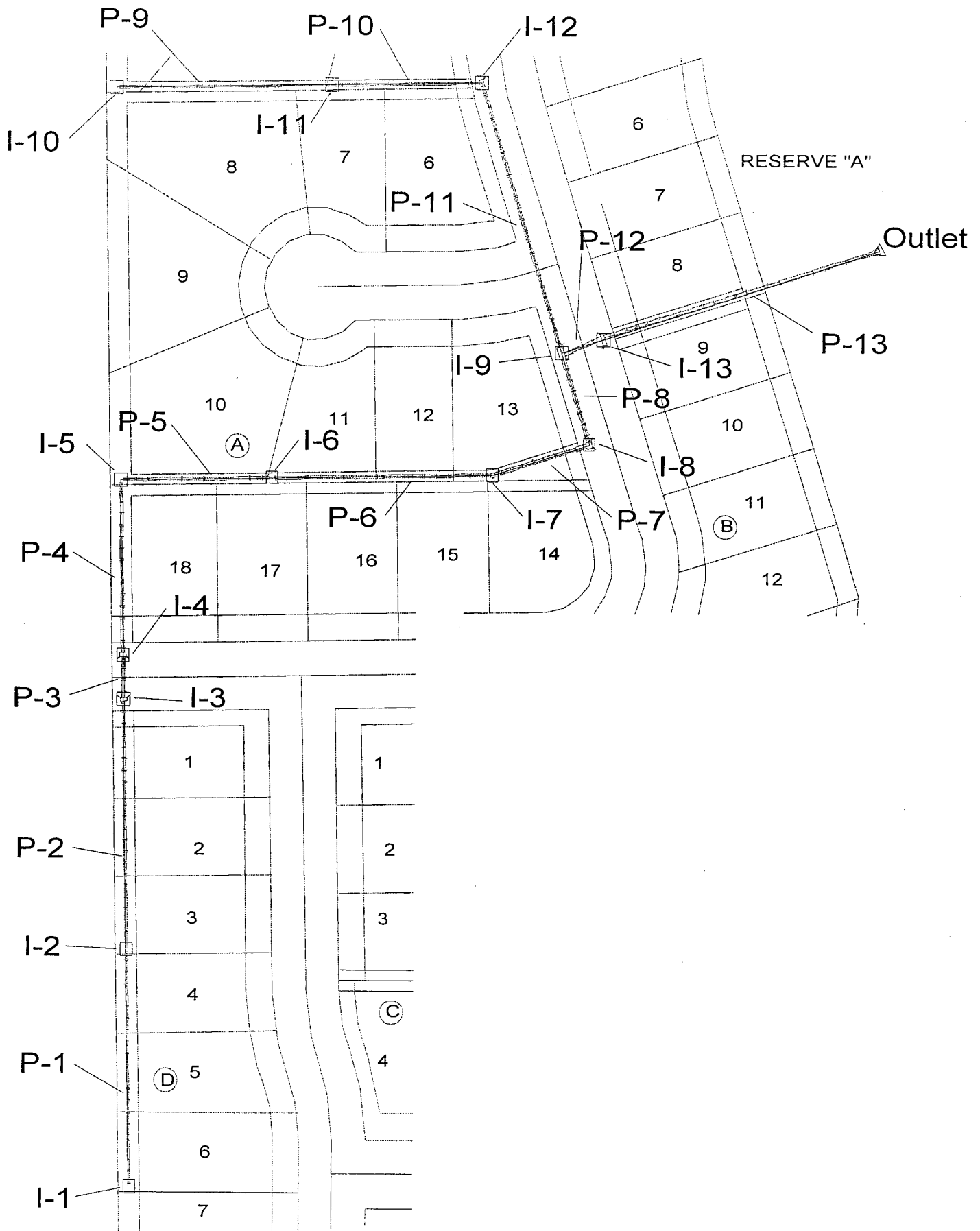

Rio Vista Estates 4th Addition
 SWS No.2, Inlet I-8

Drainage area, acres	0.5
Li = Inlet Length	5
So = street grade, ft/ft	0.008684
Sx = 'cross slope, ft/ft	0.03125
Manning's n	0.022
Z in Izzard's Eq. = 1/Sx	32

	2-yr	5-yr	100-yr
Rainfall Intensity, in/hr	3.83	4.56	7.37
Rational "C"	0.44	0.46	0.61
Flowrate, cfs	0.8	1.0	2.2
Additional Flow, cfs	0.0	0.0	0.0
Total Flowrate, cfs	0.8	1.0	2.2
depth of flow, ft	0.18	0.20	0.27
Flow width, ft	5.92	6.42	8.55
Froude Number	0.83767	0.84921	0.89065
Length 1, ft	4.36	4.80	6.70
Length 2, ft	2.87	3.15	4.40
Length 3, ft	8.18	9.00	12.56
case 1, Li < L2 intercepted flow bypassed flow	NO GOOD 1.0 0.0	NO GOOD 1.1 0.0	NO GOOD 1.7 0.6
case 2, Li > L2 intercepted flow bypassed flow	VALID 0.7 0.2	VALID 0.8 0.2	VALID 1.6 0.7

Rio Vista Estates 4th Addition
 SWS No.2, Inlet I-12

Drainage area, acres	0.2
Li = Inlet Length	5
So = street grade, ft/ft	0.005203
Sx = 'cross slope, ft/ft	0.03125
Manning's n	0.022
Z in Izzard's Eq. = 1/Sx	32

	2-yr	5-yr	100-yr
Rainfall Intensity, in/hr	3.83	4.56	7.37
Rational "C"	0.44	0.46	0.61
Flowrate, cfs	0.3	0.4	0.9
Additional Flow, cfs	0.0	0.0	0.0
Total Flowrate, cfs	0.3	0.4	0.9
depth of flow, ft	0.14	0.16	0.21
Flow width, ft	4.62	5.02	6.67
Froude Number	0.62219	0.63076	0.66154
Length 1, ft	2.53	2.78	3.89
Length 2, ft	1.66	1.83	2.55
Length 3, ft	4.74	5.22	7.29
case 1, Li < L2 intercepted flow bypassed flow	NO GOOD 0.7 0.0	NO GOOD 0.8 0.0	NO GOOD 1.2 0.0
case 2, Li > L2 intercepted flow bypassed flow	VALID 0.3 0.0	VALID 0.4 0.0	VALID 0.8 0.1

System Report

Pipe	Additional Flow (cfs)	Total Upstream Added (cfs)	Structure Discharge (cfs)	-Node- Upstream Downstream	-Section- Shape Size	Upstream Invert Elevation (ft)	Downstream Invert Elevation (ft)	-Ground- Upstream Downstream (ft)	-HGL- Upstream Downstream (ft)	-Slope- Energy Constructed (ft/ft)	-Section- Discharge Capacity (cfs)	Length (ft)	Average Velocity (ft/s)	Description
P-9	5.80	0.00	5.80	I-10	Circular 18 inch	144.80	143.80	148.30	148.23	0.003049	5.80	208.00	3.28	
P-10	4.90	5.80	10.70	I-11	Circular 24 inch	143.30	143.00	147.60	147.76	0.002237	10.70	144.00	3.41	
P-11	0.80	10.70	11.50	I-12	Circular 30 inch	142.50	141.50	149.20	147.44	0.002083	11.50	266.00	2.34	
P-1	1.80	0.00	1.80	I-9	Circular 18 inch	145.70	144.80	147.70	147.19	0.003759	25.15	223.00	1.02	
P-2	4.00	1.80	5.80	I-2	Circular 24 inch	144.30	143.80	148.40	148.96	0.004036	6.67	238.00	1.85	
P-3	6.30	5.80	12.10	I-3	Circular 30 inch	143.30	143.20	150.00	148.96	0.002101	10.37	41.00	2.46	
P-4	2.20	12.10	14.30	I-4	Circular 30 inch	143.10	142.80	150.00	148.88	0.002439	20.26	166.00	2.91	
P-5	2.70	14.30	17.00	I-5	Circular 30 inch	142.70	142.40	149.70	148.52	0.001718	17.00	145.00	3.46	
P-6	3.10	17.00	20.10	I-6	Circular 30 inch	142.30	141.90	148.40	148.27	0.002069	18.66	212.00	4.09	
P-7	3.60	20.10	23.70	I-7	Circular 36 inch	141.40	141.20	148.30	147.63	0.001887	17.82	98.00	3.35	
P-8	1.60	23.70	25.30	I-8	Circular 36 inch	141.10	140.90	148.50	147.42	0.002041	30.13	91.00	3.58	
P-12	7.10	36.80	43.90	I-9	Circular 36 inch	140.80	140.70	147.70	147.19	0.002198	31.27	42.00	6.21	
P-13	8.10	43.90	52.00	I-13	Circular 36 inch	140.60	139.00	147.70	146.70	0.002381	32.54	277.00	7.36	
				Outlet	Circular 36 inch			142.00	144.60	0.005776	50.69			

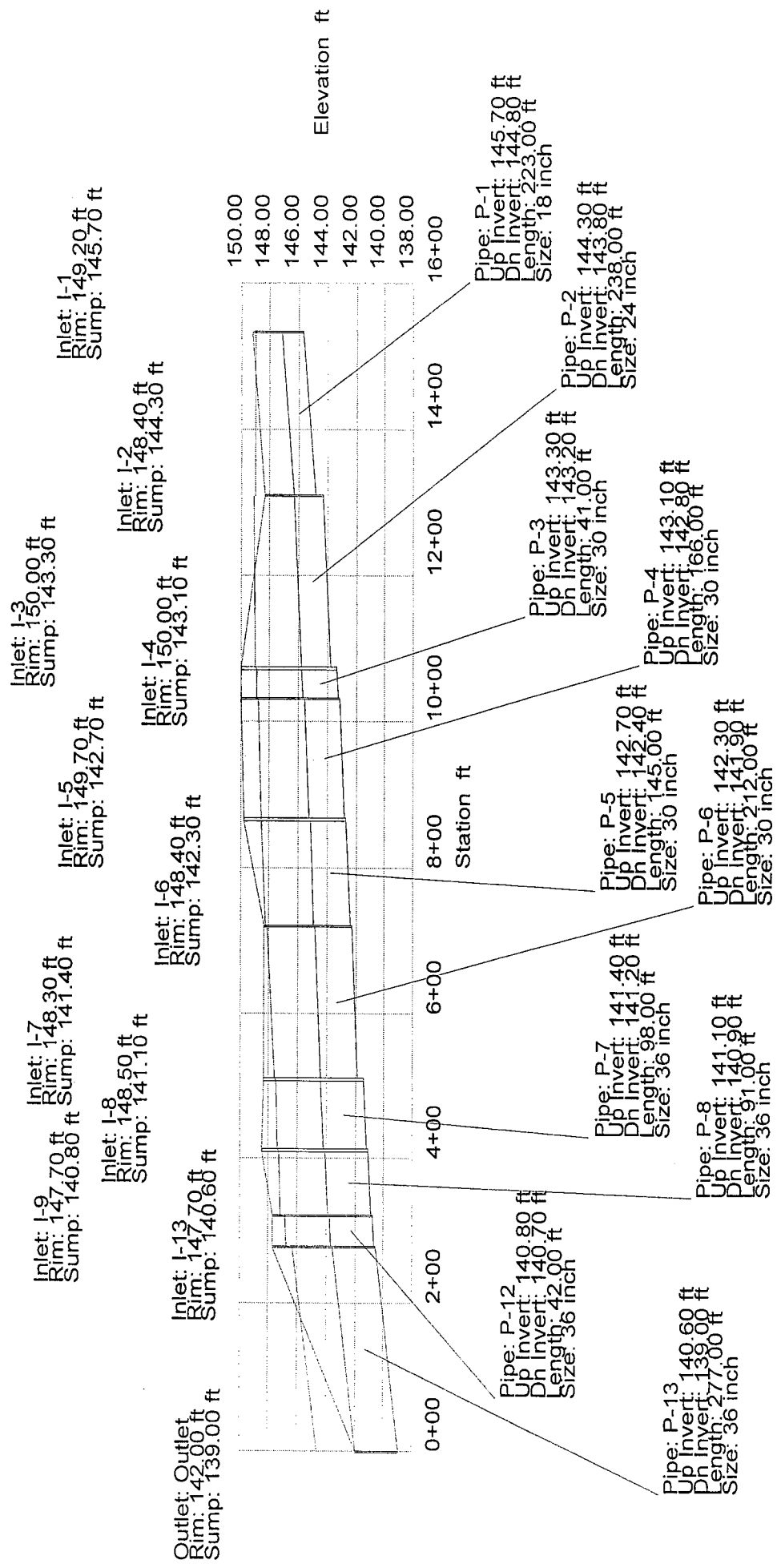

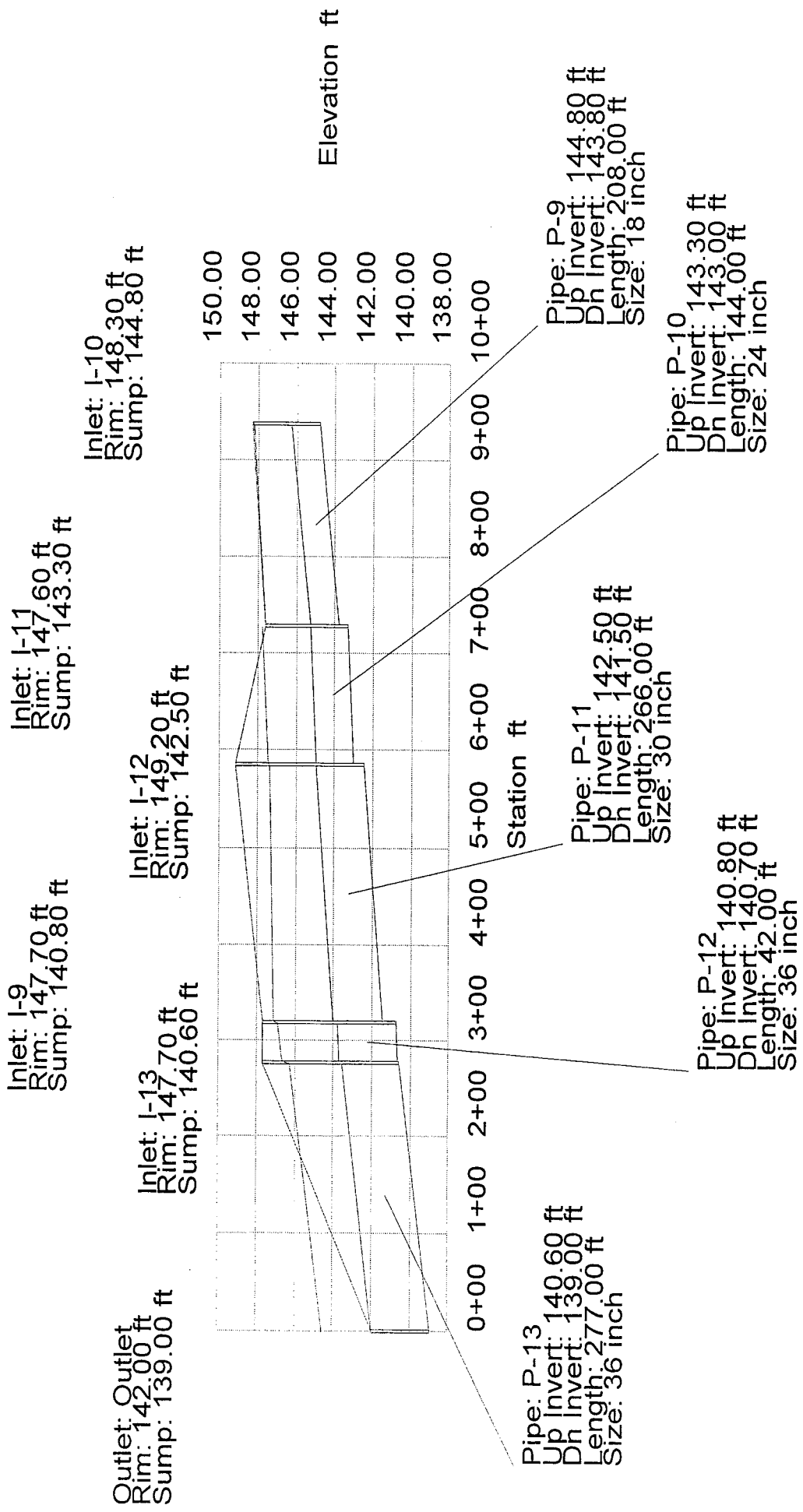

System Report

Pipe	Additional Flow (cfs)	Total Upstream Added (cfs)	Structure Discharge (cfs)	-Node- Upstream Downstream	-Section- Shape Size	Upstream Invert Elevation (ft)	Downstream Invert Elevation (ft)	-Ground- Upstream Downstream (ft)	-HGL- Upstream Downstream (ft)	-Slope- Energy Constructed (ft/ft)	-Section- Discharge Capacity (cfs)	Length (ft)	Average Velocity (ft/s)	Description
P-9	2.20	0.00	2.20	I-10	Circular 18 inch	144.80	143.80	148.30	145.37	0.002296	2.20	208.00	2.50	
P-10	1.90	2.20	4.10	I-11	Circular 24 inch	143.30	143.00	147.60	145.04	0.000309	4.10	144.00	1.36	
P-11	0.30	4.10	4.40	I-12	Circular 30 inch	142.50	141.50	149.20	145.00	0.002083	4.40	266.00	0.90	
P-1	0.70	0.00	0.70	I-9	Circular 18 inch	145.70	144.80	147.70	144.97	0.003759	25.15	223.00	1.96	
P-2	1.50	0.70	2.20	I-2	Circular 24 inch	144.30	143.80	148.40	145.27	0.004036	6.67	238.00	1.20	
P-3	2.40	2.20	4.60	I-3	Circular 30 inch	143.30	143.20	150.00	145.22	0.002101	10.37	41.00	1.12	
P-4	0.80	4.60	5.40	I-4	Circular 30 inch	143.10	142.80	150.00	145.20	0.002439	20.26	166.00	1.18	
P-5	1.00	5.40	6.40	I-5	Circular 30 inch	142.70	142.40	149.70	145.17	0.001807	17.44	145.00	1.31	
P-6	1.20	6.40	7.60	I-6	Circular 30 inch	142.30	141.90	148.40	145.12	0.002069	18.66	212.00	1.55	
P-7	1.30	7.60	8.90	I-7	Circular 36 inch	141.40	141.20	148.30	145.03	0.001887	17.82	98.00	1.26	
P-8	0.70	8.90	9.60	I-8	Circular 36 inch	141.10	140.90	148.50	145.02	0.000178	8.90	91.00	1.36	
P-12	2.60	14.00	16.60	I-9	Circular 36 inch	140.80	140.70	147.70	144.97	0.002198	31.27	42.00	2.35	
P-13	3.00	16.60	19.60	I-13	Circular 36 inch	140.60	139.00	147.70	144.90	0.002381	32.54	277.00	2.77	
				Outlet	Circular 36 inch			142.00	144.60	0.005776	50.69			

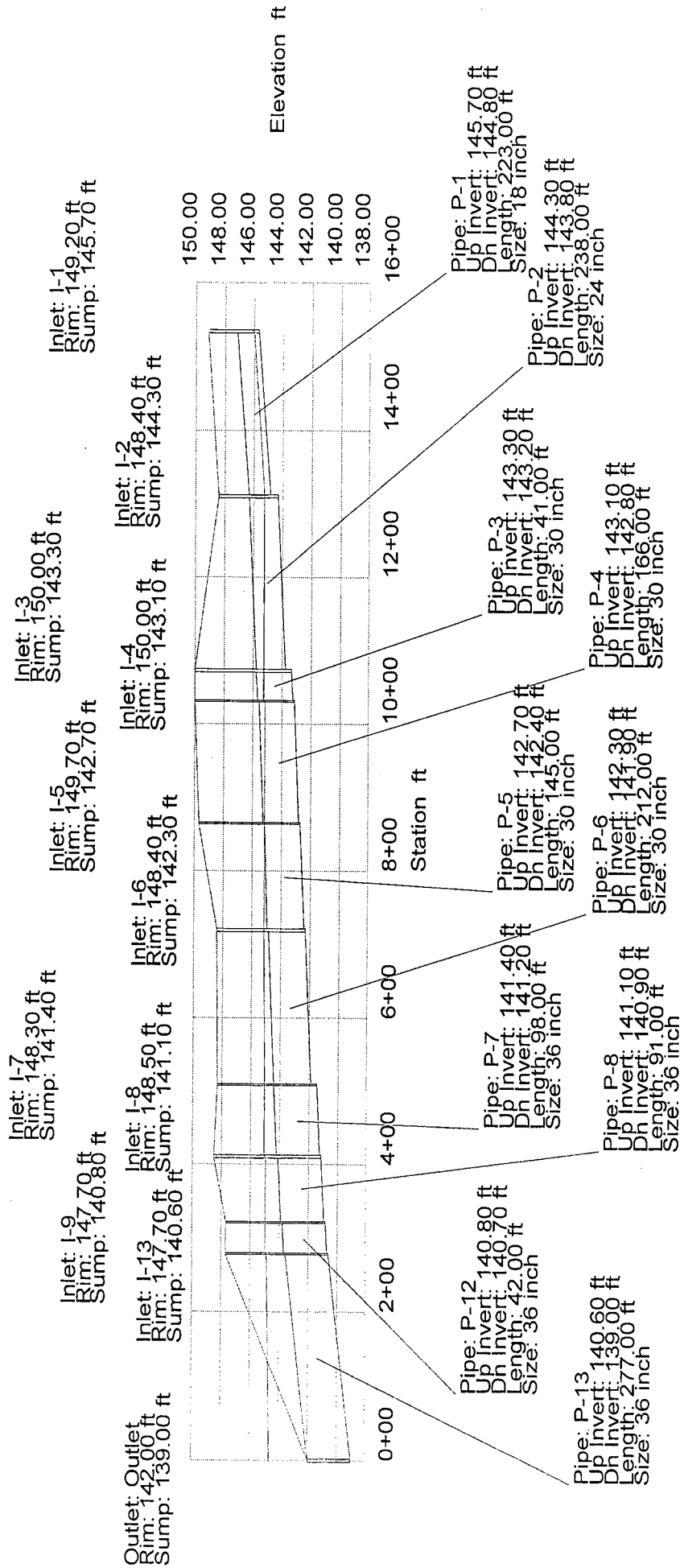

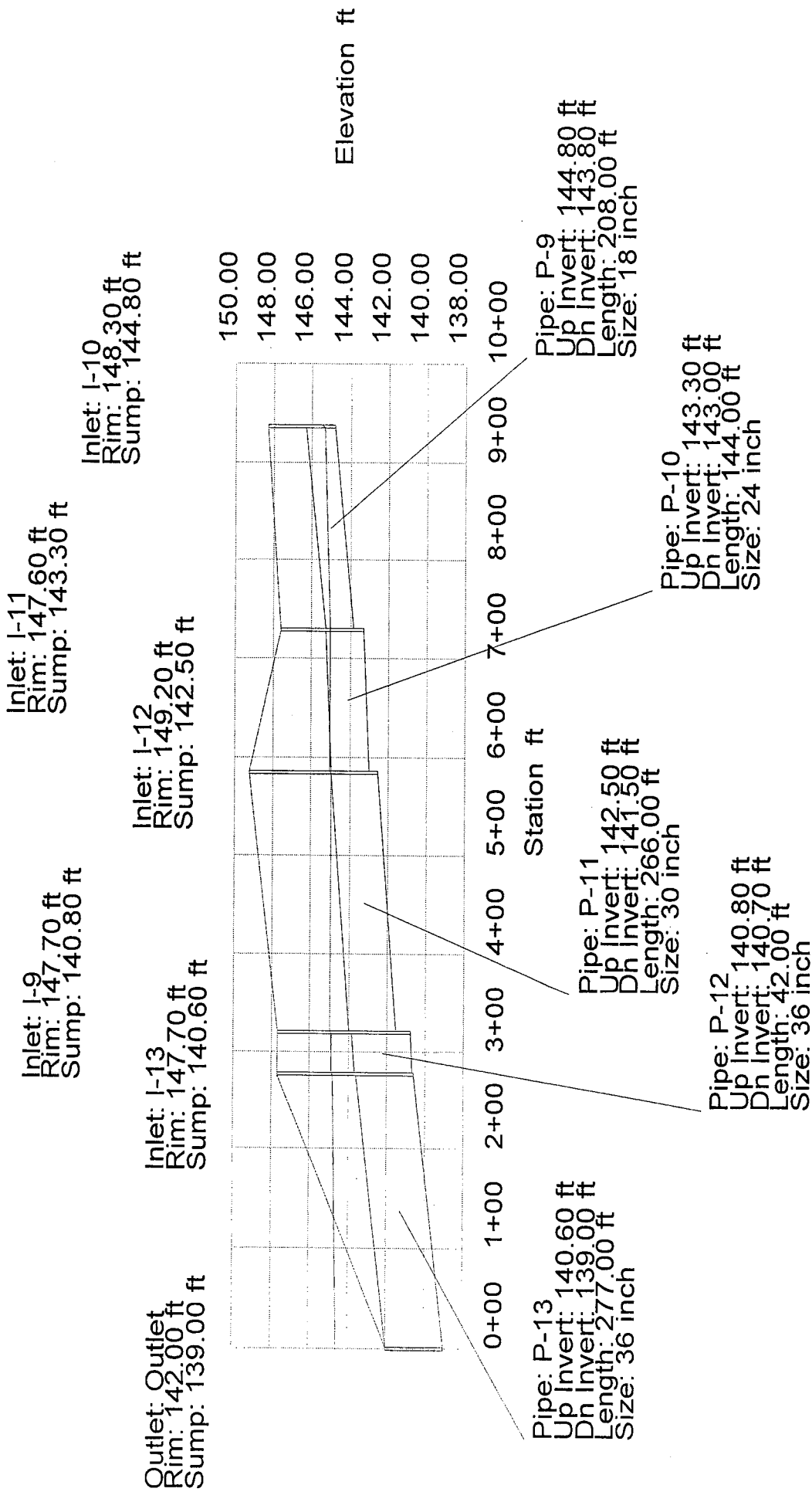

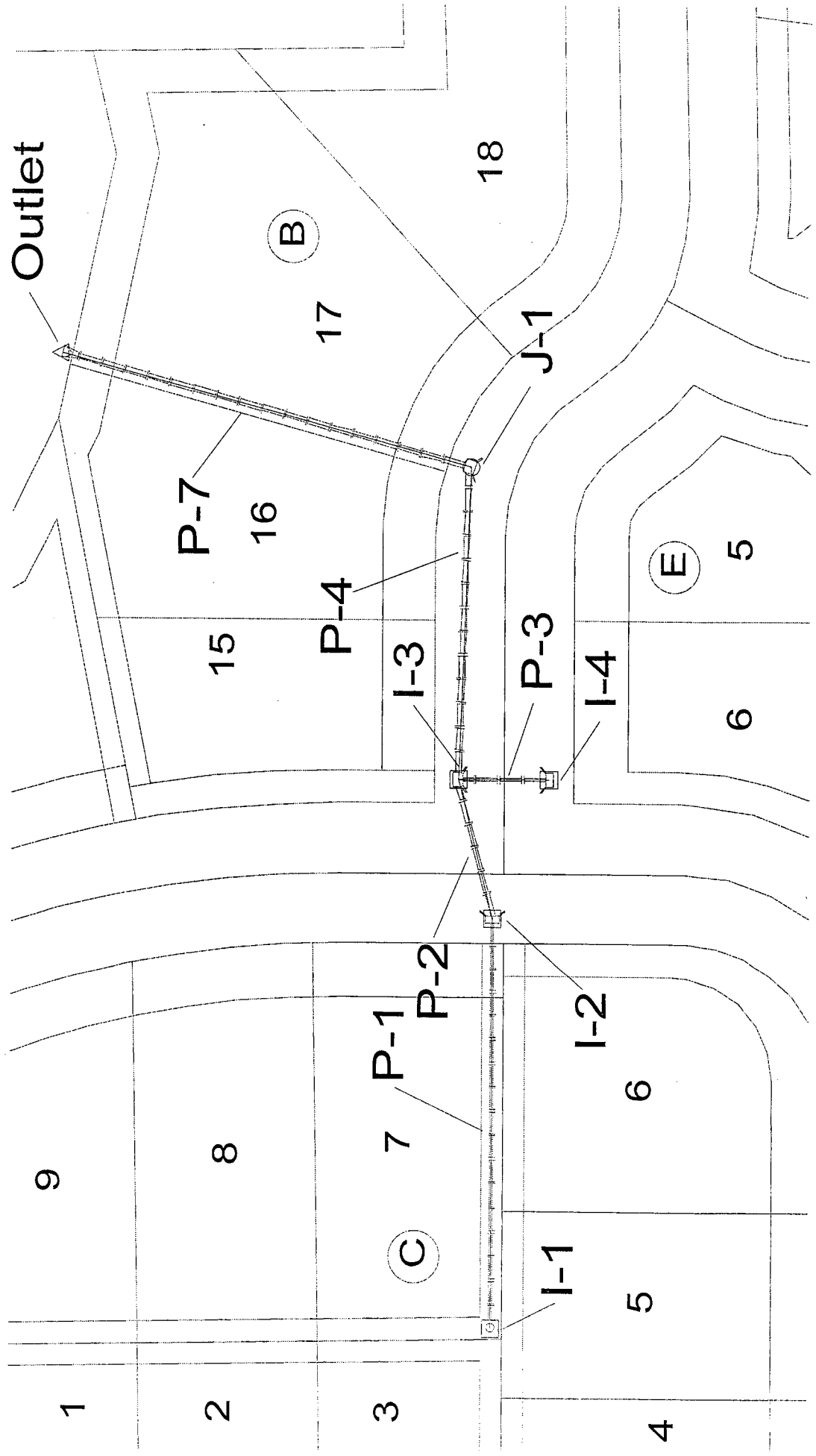

System Report

Pipe	Additional Flow (cfs)	Total Upstream Added (cfs)	Structure Discharge (cfs)	-Node- Upstream Downstream	-Section- Shape Size	Upstream Invert Elevation (ft)	Downstream Invert Elevation (ft)	-Ground- Upstream Downstream (ft)	-HGL- Upstream Downstream (ft)	-Slope- Energy Constructed (ft/ft)	-Section- Discharge Capacity (cfs)	Length (ft)	Average Velocity (ft/s)	Description
P-3	10.00	0.00	10.00	I-4	Circular 18 inch	143.60	143.40	148.40	146.79	0.009064	10.00	41.00	5.66	
P-1	9.40	0.00	9.40	I-1	Circular 18 inch	144.20	143.60	147.70	146.42	0.004878	7.34	188.00	5.32	
P-2	5.40	9.40	14.80	I-2	Circular 24 inch	143.10	142.90	148.70	146.87	0.003191	5.93	66.00	4.71	
P-4	4.00	24.80	28.80	I-3	Circular 30 inch	142.40	142.10	148.40	146.42	0.003030	12.45	143.00	5.87	
P-7	N/A	28.80	28.80	J-1	Circular 30 inch	142.00	140.50	149.10	145.44	0.002098	18.79	198.00	5.87	
				Outlet				145.00	144.20	0.007576	35.70			

Inlet: I-3
 Rim: 148.40 ft
 Sump: 141.80 ft

Inlet: I-1
 Rim: 147.70 ft
 Sump: 144.20 ft

Inlet: I-2
 Rim: 148.70 ft
 Sump: 143.10 ft

Junction: J-1
 Rim: 149.10 ft
 Sump: 142.00 ft

Outlet: Outlet
 Rim: 145.00 ft
 Sump: 140.50 ft

150.00
 149.00
 148.00
 147.00
 146.00
 145.00
 144.00
 143.00
 142.00
 141.00
 140.00

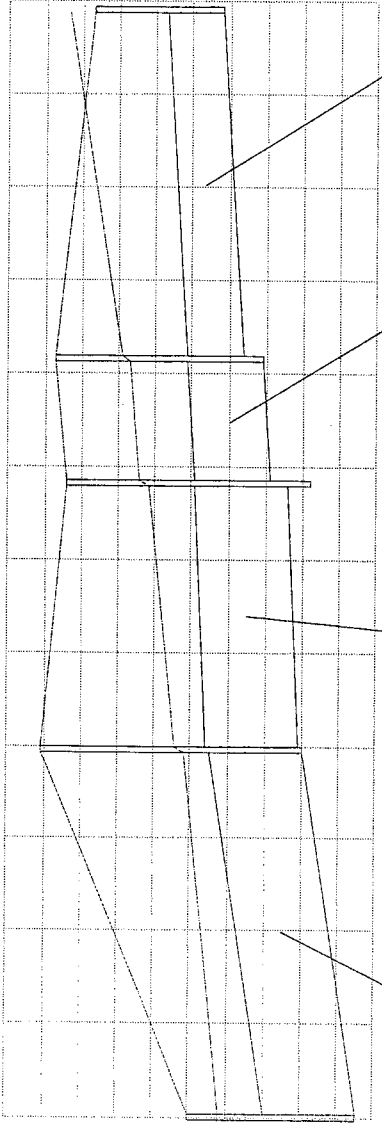

Elevation ft

0+00+501+002+503+003+504+004+505+005+506+00

Station ft

Pipe: P-1
 Up Invert: 144.20 ft
 Dn Invert: 143.60 ft
 Length: 188.00 ft
 Size: 18 inch

Pipe: P-4
 Up Invert: 142.40 ft
 Dn Invert: 142.10 ft
 Length: 143.00 ft
 Size: 30 inch

Pipe: P-7
 Up Invert: 142.00 ft
 Dn Invert: 140.50 ft
 Length: 198.00 ft
 Size: 30 inch

Pipe: P-2
 Up Invert: 143.10 ft
 Dn Invert: 142.90 ft
 Length: 66.00 ft
 Size: 24 inch

Inlet: I-4
 Rim: 148.40 ft
 Sump: 143.60 ft

Junction: J-1
 Rim: 149.10 ft
 Sump: 142.00 ft

Outlet: Outlet
 Rim: 145.00 ft
 Sump: 140.50 ft

Inlet: I-3
 Rim: 148.40 ft
 Sump: 141.80 ft

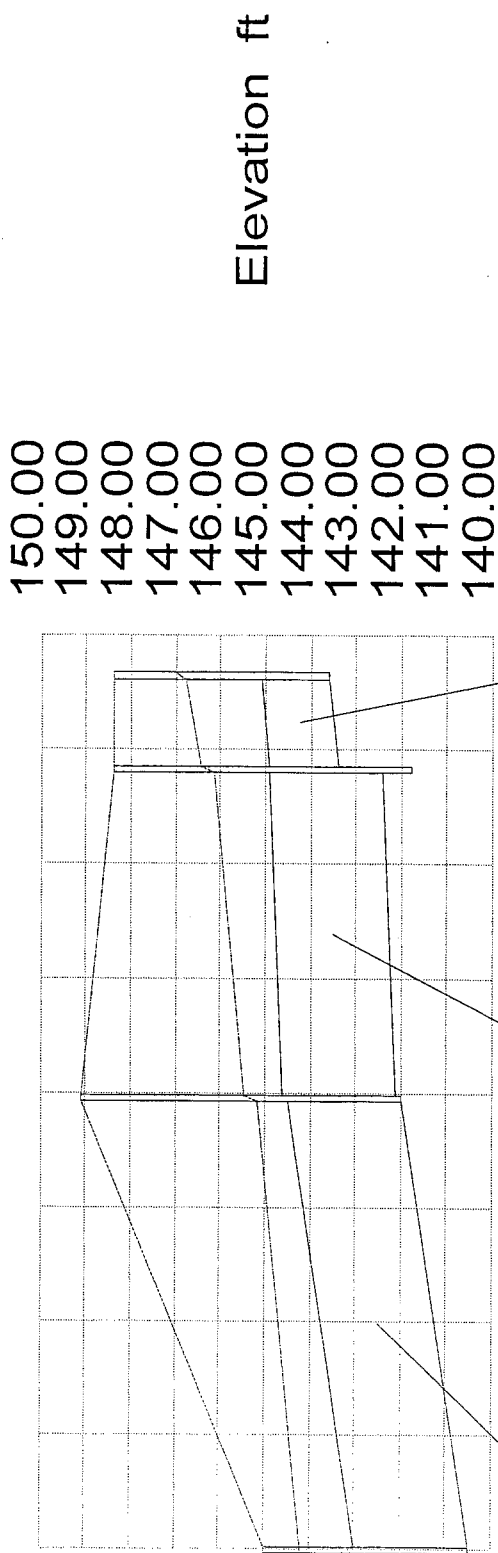

0+000+501+001+502+002+503+003+504+00

Station ft

Elevation ft

Pipe: P-7
 Up Invert: 142.00 ft
 Dn Invert: 140.50 ft
 Length: 198.00 ft
 Size: 30 inch

Pipe: P-4
 Up Invert: 142.40 ft
 Dn Invert: 142.10 ft
 Length: 143.00 ft
 Size: 30 inch

Pipe: P-3
 Up Invert: 143.60 ft
 Dn Invert: 143.40 ft
 Length: 41.00 ft
 Size: 18 inch

System Report

Pipe	Additional Flow (cfs)	Total Upstream Added (cfs)	Structure Discharge (cfs)	-Node- Upstream Downstream	-Section- Shape Size	Upstream Invert Elevation (ft)	Downstream Invert Elevation (ft)	-Ground- Upstream Downstream (ft)	-HGL- Upstream Downstream (ft)	-Slope- Energy Constructed (ft/ft)	-Section- Discharge Capacity (cfs)	Length (ft)	Average Velocity (ft/s)	Description
P-3	3.90	0.00	3.90	I-4	Circular 18 inch	143.60	143.40	148.40	144.54	0.002162	3.90	41.00	3.08	
P-1	3.50	0.00	3.50	I-1	Circular 18 inch	144.20	143.60	147.70	145.03	0.002745	3.50	188.00	3.19	
P-2	2.00	3.50	5.50	I-2	Circular 24 inch	143.10	142.90	148.70	144.57	0.003191	5.50	66.00	2.16	
P-4	1.50	9.40	10.90	I-3	Circular 30 inch	142.40	142.10	148.40	144.45	0.000657	10.90	143.00	2.43	
P-7	N/A	10.90	10.90	J-1	Circular 30 inch	142.00	140.50	149.10	144.37	0.002098	10.90	198.00	2.25	
				Outlet				145.00	144.20	0.007576	35.70			

Inlet: I-3
 Rim: 148.40 ft
 Sump: 141.80 ft

Inlet: I-1
 Rim: 147.70 ft
 Sump: 144.20 ft

Inlet: I-2
 Rim: 148.70 ft
 Sump: 143.10 ft

Junction: J-1
 Rim: 149.10 ft
 Sump: 142.00 ft

Outlet: Outlet
 Rim: 145.00 ft
 Sump: 140.50 ft

150.00
 149.00
 148.00
 147.00
 146.00
 145.00
 144.00
 143.00
 142.00
 141.00
 140.00

Elevation ft

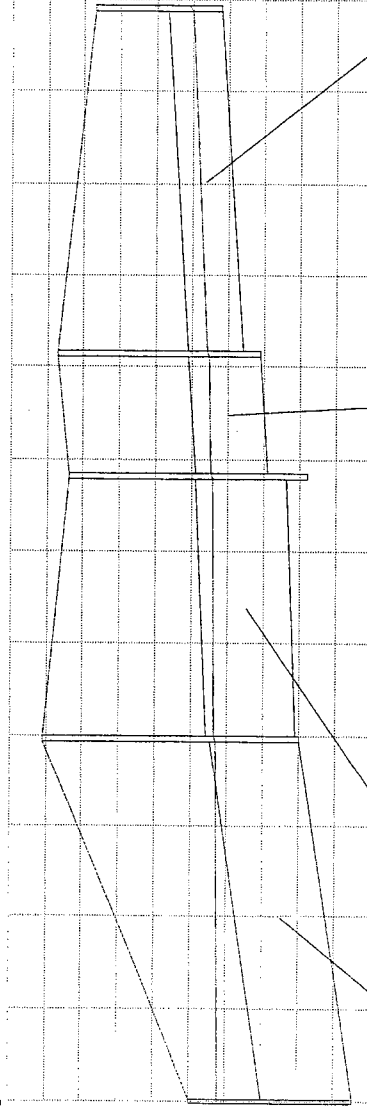

0+00+501+001+502+002+503+003+504+004+505+005+506+00

Station ft

Pipe: P-4
 Up Invert: 142.40 ft
 Dn Invert: 142.10 ft
 Length: 143.00 ft
 Size: 30 inch

Pipe: P-7
 Up Invert: 142.00 ft
 Dn Invert: 140.50 ft
 Length: 198.00 ft
 Size: 30 inch

Pipe: P-2
 Up Invert: 143.10 ft
 Dn Invert: 142.90 ft
 Length: 66.00 ft
 Size: 24 inch

Pipe: P-1
 Up Invert: 144.20 ft
 Dn Invert: 143.60 ft
 Length: 188.00 ft
 Size: 18 inch

Inlet: I-3
 Rim: 148.40 ft
 Sump: 141.80 ft

Inlet: I-4
 Rim: 148.40 ft
 Sump: 143.60 ft

Junction: J-1
 Rim: 149.10 ft
 Sump: 142.00 ft

Outlet: Outlet
 Rim: 145.00 ft
 Sump: 140.50 ft

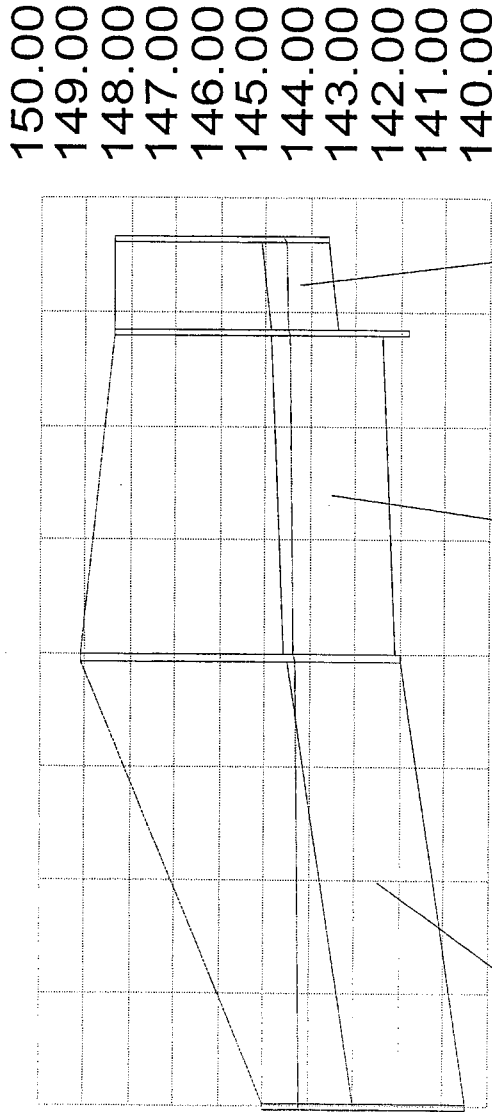

0+00+501+001+502+002+503+003+504+00

Station ft

Elevation ft

Pipe: P-7
 Up Invert: 142.00 ft
 Dn Invert: 140.50 ft
 Length: 198.00 ft
 Size: 30 inch

Pipe: P-4
 Up Invert: 142.40 ft
 Dn Invert: 142.10 ft
 Length: 143.00 ft
 Size: 30 inch

Pipe: P-3
 Up Invert: 143.60 ft
 Dn Invert: 143.40 ft
 Length: 41.00 ft
 Size: 18 inch

Drainage Plan Sheet

Sub-Division Grading Plan

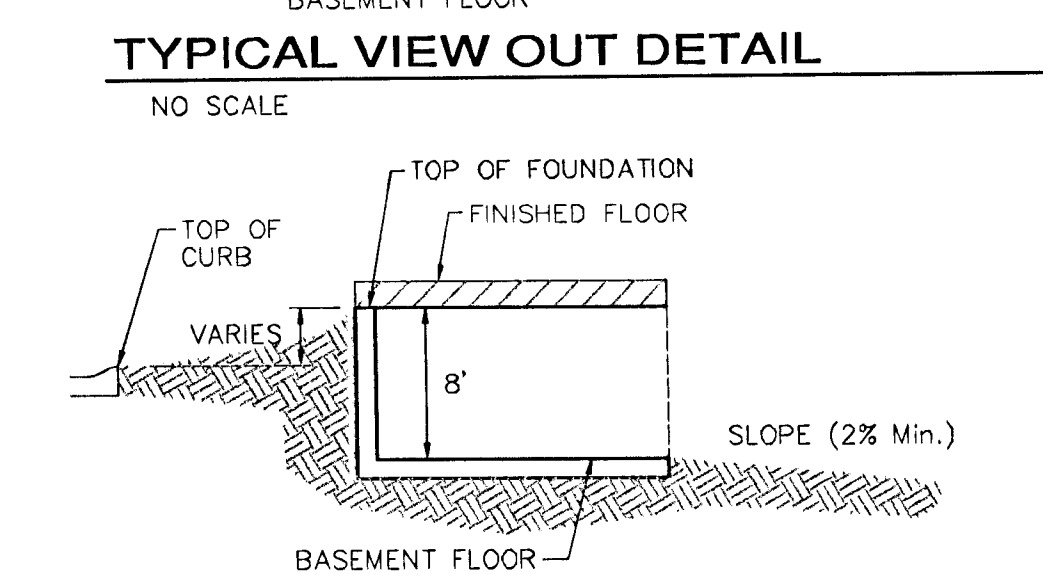
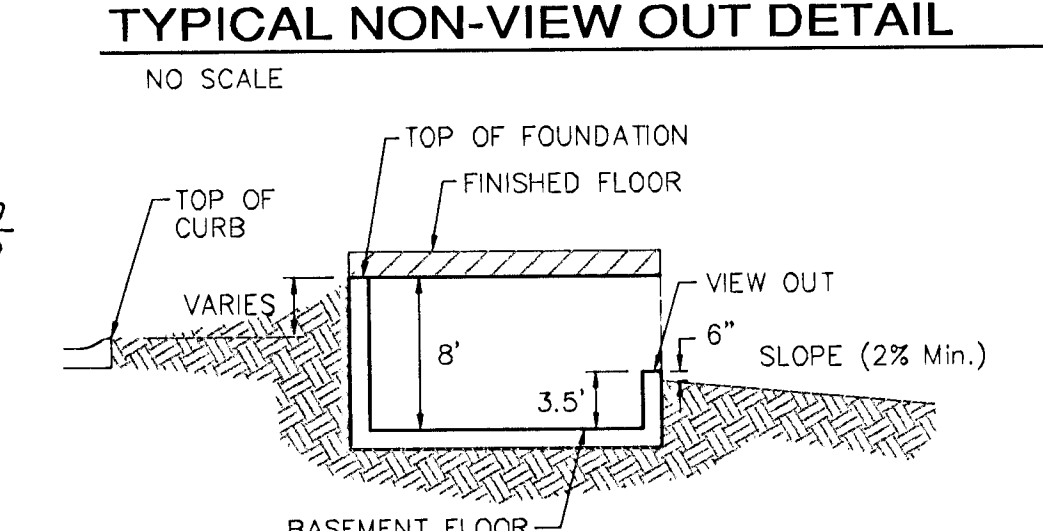
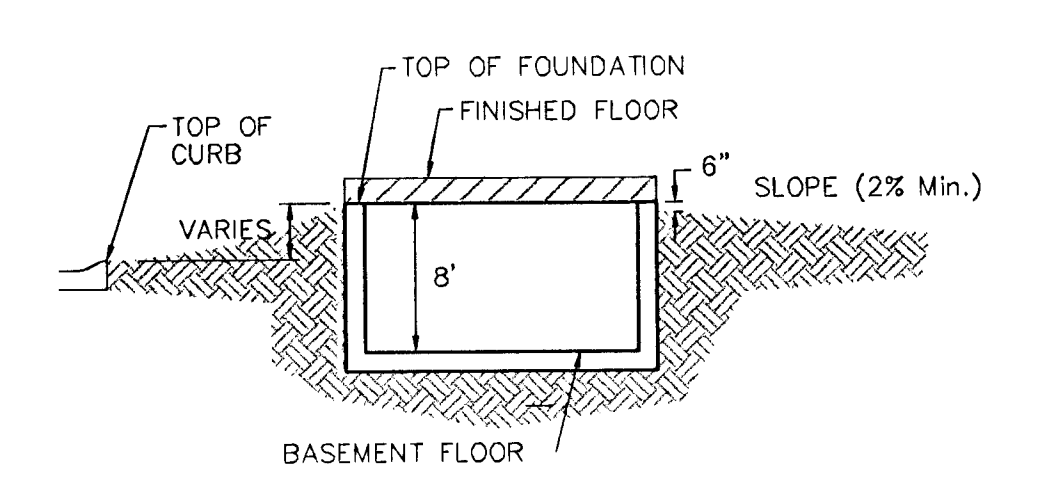
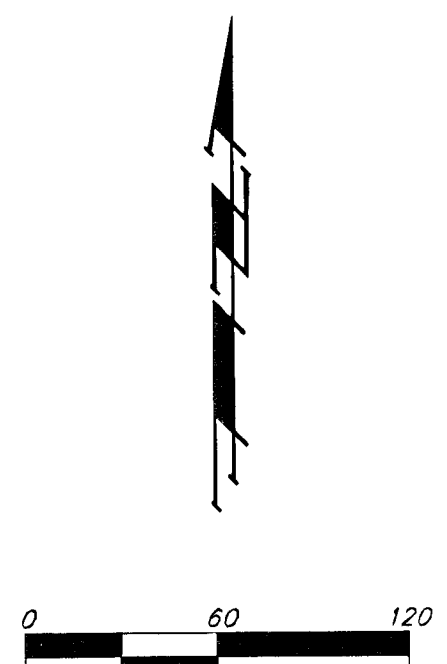
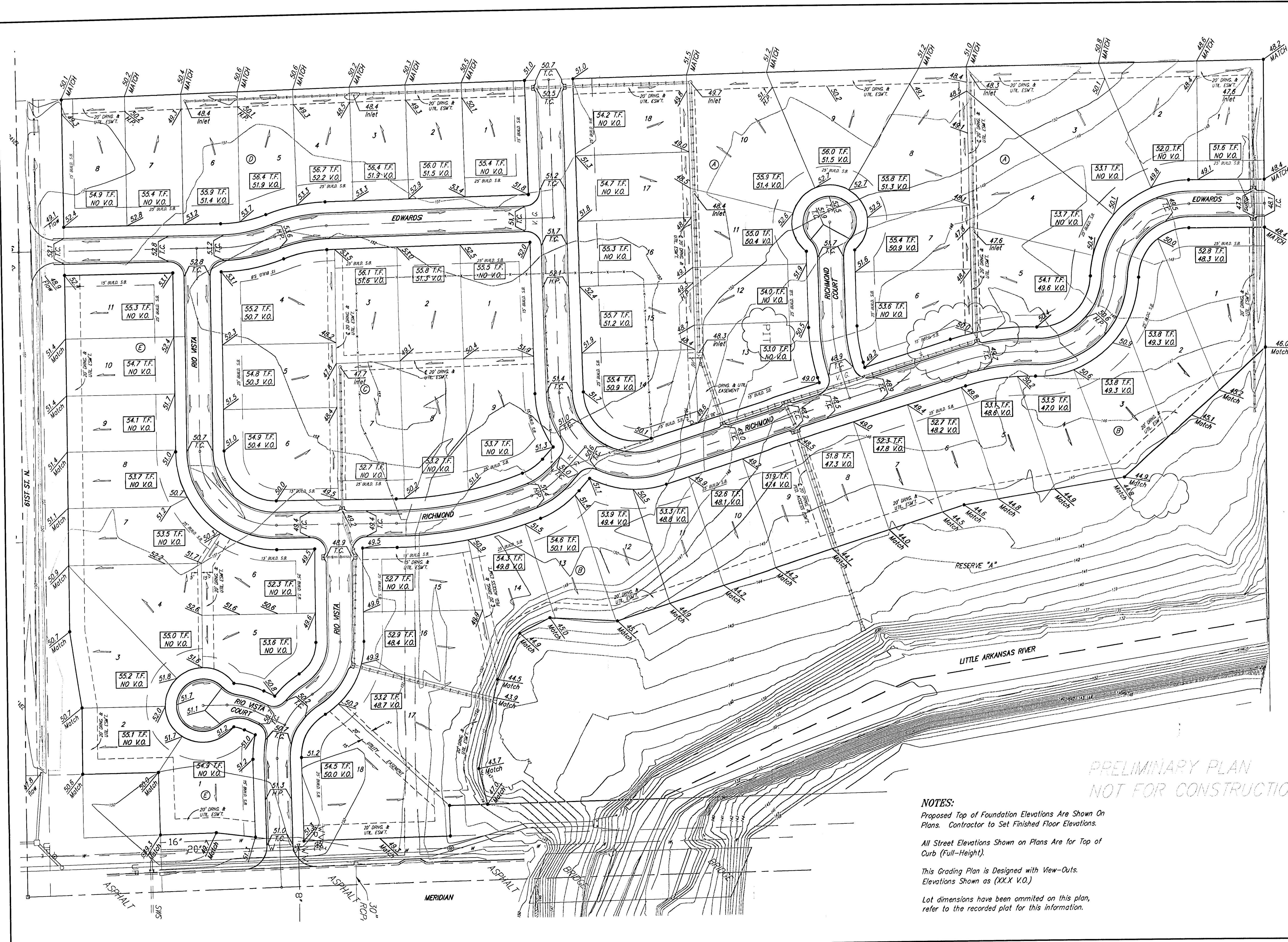

MINIMUM BUILDING PAD ELEVATIONS FOR LOWEST OPENING TO THE STRUCTURES			
LOT	BLOCK	ELEVATION	
		MSL	CITY DATUM
1-18	B	1333.6	146.2

BENCHMARK:
R.R. SPIKE IN HLP, 150' E. & 30' S. OF THE S.W. COR., S.E. 1/4, SEC. 12-26-1W.
ELEV. = 1338.96 M.S.L.
ELEV. = 151.56 City Datum

"O" IN OPEN, TOP FLANGE OF FIRE HYDRANT AT THE S.W. CORNER OF 61ST. ST. N. & MERIDIAN AVE.
ELEV. = 1339.16 M.S.L.
ELEV. = 151.76 City Datum

PRELIMINARY PLAN
NOT FOR CONSTRUCTION

NOTES:
Proposed Top of Foundation Elevations Are Shown on Plans. Contractor to Set Finished Floor Elevations.
All Street Elevations Shown on Plans Are for Top of Curb (Full-Height).
This Grading Plan is Designed with View-Outs. Elevations Shown as (X.X' V.O.)
Lot dimensions have been omitted on this plan, refer to the recorded plat for this information.

RIO VISTA ESTATES 4TH ADDITION
GRADING PLAN
WICHITA, KANSAS

BAUGHMAN COMPANY P.A.
ENGINEERING, SURVEYING, & PLANNING
316-282-7271 • 315 ELLIS • WICHITA, KANSAS 67211

PROJECT NUMBER: _____ SHEET **1** OF **1**

DESIGN: BLG	DRAWN: BLG	APPROVED:	DATE: 23DEC2002	SCALE: NOTED
-------------	------------	-----------	-----------------	--------------