

BENCHMARK:  
CITY OF WICHITA BENCHMARK DISC -  
SE COR. OF THE INTERSECTION OF TYLER RD. &  
29TH STREET NORTH.  
32.30' S. OF &  
30.00' E. OF &  
55.50' E. OF P.P.  
9.20' SE. OF P.P.  
43.20' SE. OF SEC. COR. IRON  
ELEV. = 178.04 CITY DATUM  
1365.44 NAD83

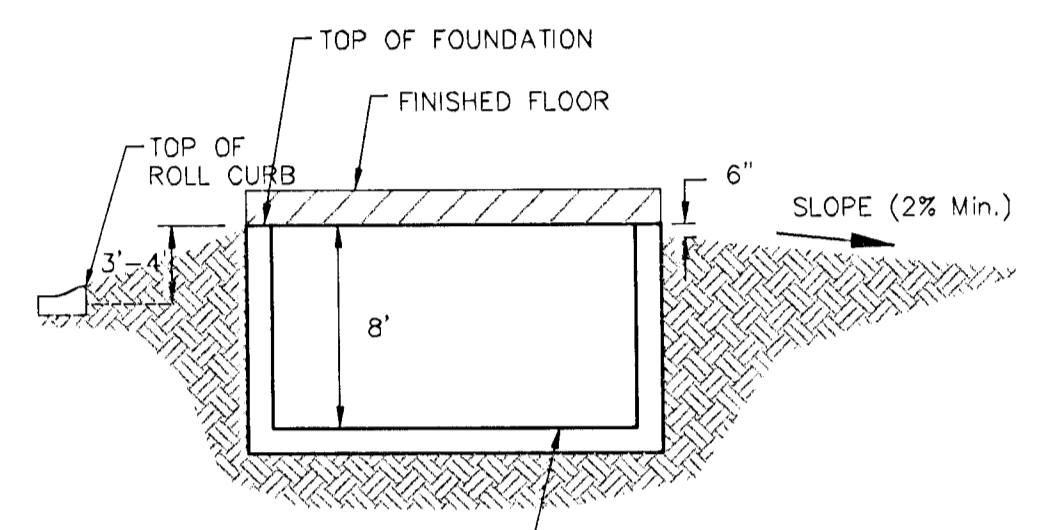

TYPICAL NON-VIEW OUT  
NO SCALE

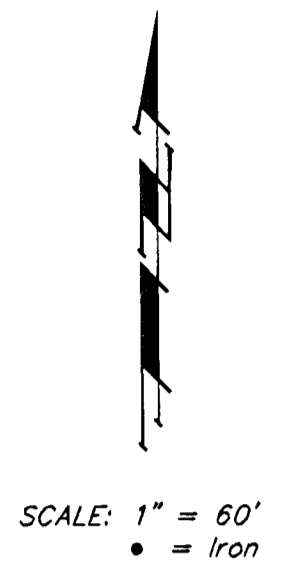
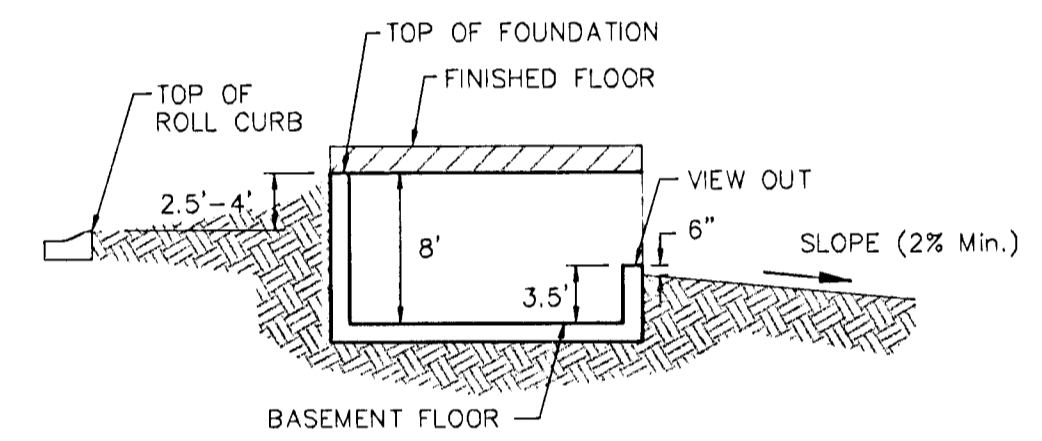

TYPICAL VIEW OUT  
NO SCALE

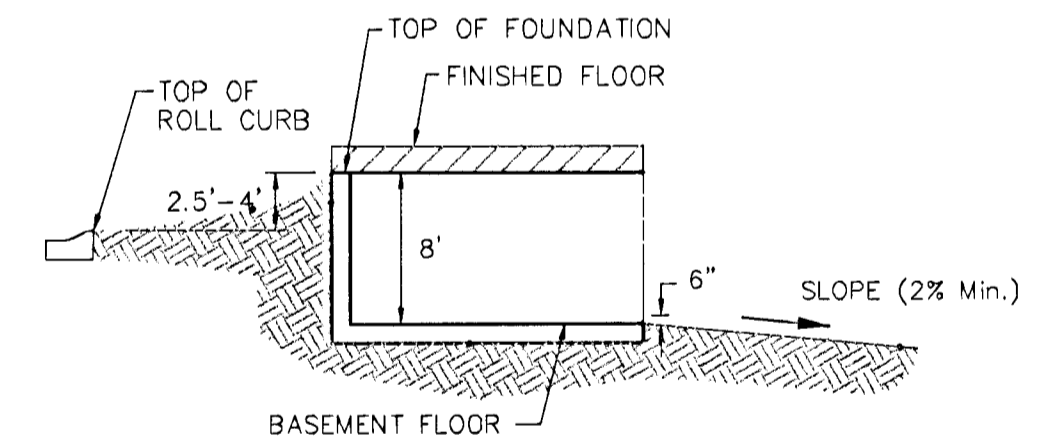

TYPICAL WALK OUT  
NO SCALE

Notes:  
Proposed Top of Foundation Elevations Are Shown On Plans.  
Contractor to Set Finished Floor Elevations.  
All Street Elevations Shown on Plans Are for Top of Curb.  
This Grading Plan is Designed with View-Outs.  
Elevations Shown at Rear of House (XX.X V.O.)  
Lot dimensions have been omitted on this plan, refer to the recorded plat for this information.

TYLER'S LANDING ADDITION  
**MASTER GRADING PLAN**  
CITY OF WICHITA, KANSAS  
**BAUGHMAN COMPANY P.A.**  
ENGINEERING, SURVEYING, & PLANNING  
316-262-7271 • 315 ELLIS • WICHITA, KANSAS 67211

DESIGN SCL	DRAWN SCL	APPROVED NBW	DATE 11/04/02	SCALE 1"=60'	SHEET 2
PROJECT NUMBER					OF 2

GRADE DWG