



Department of Public Works

August 16, 2005

Mr. Greg Allison, P.E.
MKEC Engineering Consultants, Inc.
411 N. Webb Road
Wichita, KS 67206

SUBJECT: Drainage Plan
Auburn Hills Commercial 4th Addition
Wichita, Kansas

Greg:

We have completed our first review of the submittal for the subject site with regards to the City of Wichita's stormwater and floodplain policies. The items submitted for our review were as follows:

1. Bound Report entitled "Drainage Plan, Auburn Hills Commercial 4th Addition, Wichita, Sedgwick County, Kansas" prepared by Baughman Company and submitted on August 3, 2005.

Based upon the above item, we offer the following comments:

1. The plan sheets and report should be stamped and signed by a Kansas Licensed Professional Engineer, including the P.E. expiration date.
2. The proposed stormwater pipe system should be either sized to have the capacity for the 100-year storm event or the plan sheet should be noted to have final site grades established that will be tributary to the proposed detention facility.
3. The existing and proposed contours should be clearly labeled and coincide with the areas used in the stage-storage-discharge relationship found in the calculations. This relationship should be included on the plan sheet for future reference.
4. The detention facilities shall provide an overflow structure and overflow path that can safely pass excess flows through the development site. The location of the proposed overflow from the detention facility should be shown on the plan set. The capacity of the overflow channel structure/channel should have a minimum of 1 cfs/acre.

Engineering Division

City Hall • 7th Floor • 455 North Main • Wichita, Kansas 67202-1620

T 316.268.4501 **F** 316.268.4114

www.wichitagov.org

5. A detail of the overflow weir or emergency flow path should be included on the plan set including all relevant dimensions and elevations.
6. The City of Wichita requires a minimum of one-foot free board to be provided on all detention facilities. There is not enough information on the plan to verify the freeboard requirements.
7. As a reminder, Drainage Easements need to be provided over/about the on-site storm sewer system, and the over land drainage swales, which are necessary to convey the 100-year storm event to the detention facility.
8. As a reminder, An electronic copy of the drainage plan, grading plan, supporting documentation, and input files for the modeling should be included on a CD and enclosed in the bound report.

We are requesting a comment and response letter to be bound behind the cover of the resubmitted drainage report. If you have any questions or concerns regarding this review, please contact me by phone at 268-4624 or email at slindebak@wichita.gov.

Sincerely,

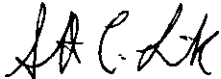

Scott C. Lindebak, P.E.
Civil Engineer

cc: file
Vicky Huang, Subdivision Engineer

MKEC ENGINEERING CONSULTANTS, INC.

Kansas City Oklahoma City Wichita

September 23, 2005

Mr. Scott C. Lindebak, P.E.
City of Wichita
Department of Public Works
455 N. Main – 7th Floor
Wichita, Kansas 67202

Reference: Auburn Hills Commercial 4th Addition - Drainage Plan
Wichita, Kansas
MKEC Project Number 05403

Dear Scott:

We have completed the revisions to the Auburn Hills Commercial 4th Drainage Plan in response to your letter dated August 16, 2005. The following items correspond to the comments in our letter and explain how these comments have been addressed.

1. The plan sheets and report have been stamped and signed by a Kansas Licensed Professional Engineer.
2. The stormwater pipe systems draining to the proposed pond have been sized for the 5-year storm. All areas serviced by these systems will be graded so events in excess of the 5-year storm will drain into the proposed pond.
3. The existing and proposed contours have been clearly labeled and coincide with the areas used in the stage-storage-discharge relationship found in the calculations. A table showing the stage-storage-discharge relationship is shown in the drainage & utility plan.
4. An overflow channel has been designed to safely pass excess flows through the development site. This channel will have a capacity of approximately 24 cfs for the 17 acres tributary to the pond and the 7 cfs flowing into the channel from the property to the east.
5. A call out showing all relevant dimensions of the overflow channel is included on the drainage & utility plan.
6. Contours have been included around the pond showing the required freeboard surrounding the pond.
7. Drainage Easements by separate instrument will be determined once a final site layout is determined.
8. An electronic copy of the drainage report has been included for the City of Wichita's use.

Providing Professional Service Since 1982

411 NORTH WEBB ROAD WICHITA, KS 67206 T 316.684.9600 F 316.684.5100

Mr. Scott Lindebak
September 23, 2005

Page 2

Thank you for your review of this drainage plan. Please let me know if there are any other issues that need to be resolved.

Sincerely,

MKEC ENGINEERING CONSULTANTS, INC.

A handwritten signature in cursive script that reads "Adam Koster".

Adam Koster, E.I.T.

Cc: Gary Oborny, Occidental Mgmt

Drainage Report

Auburn Hills Commercial 4th Addition

Wichita, Sedgwick County, Kansas

Location

The subject property is in the city of Wichita, Sedgwick County, Kansas. The proposed development is located south of Maple Street and east of 135th Street West, in the NW ¼ of Section 25, Township 27 South, Range 2 West. The site is approximately 4.6 acres and was previously platted in Auburn Hills Commercial 3rd Addition. The entry for the site will be located on Maple Street. The site is shown on the Sedgwick County, Kansas Quadrangle, located in Appendix A.

Soils

According to the NRCS (SCS) Sedgwick County Soil Survey (Appendix B) soils on the site are Vanoss silt loam, 1 to 3 percent slopes, (Vb – HSG “B”). The Hydrologic Soil Group used to select runoff coefficients for the site is “B”.

Pre-Project Conditions

Pre-Project Development

The site is currently vacant, but was previously platted for commercial use.

Pre-Project Landform and Slope

Slopes across the site range from 0.5-2.0%.

Pre-Project Drainage Conditions

The site is entirely in Zone C, areas of minimal flooding. The nearest Zone B, area 500-year flood, is located approximately 1000 feet east of the site. The nearest Zone A1, area within the 100-year flood plain, is located approximately 1080 feet east of the site (FIRM Panel 200, Sedgwick County, Kansas, June 3, 1986) (Appendix C).

Pre-Project Runoff Characteristics

The site drains from south to north into an existing detention pond on the north side of the property. The pond was designed to provide detention for the site as well as approximately 12.7 acres of commercial land west of the property, and approximately 1.4 acres of residential land east of the property. Two-15” CERTA LOK PVC pipes act as the pond’s outlet structure. This system routes water from the pond to an existing concrete flume on the north side of Maple Street. The flume then routes the runoff east into an existing pond. The existing conditions were modeled in Hydraflow Hydrographs by Intelisolve (Appendix D), using the information provided by the Auburn Hills

Commercial 3rd Drainage Plan, in order to determine the existing flow offsite. Table 1 summarizes the calculated flows under Auburn Hills Commercial 3rd Conditions.

Table 1. Pre-Project Flow Summary

	2-yr	5-yr	10-yr	100-yr
Flow to Pond	64.1	75.7	86.9	122.6
Flow out of Pond (2-15" PVC)	14.1	15.8	17.2	21.1
Flow Onto Maple St.	0.0	0.0	0.0	0.0
Total Flow Offsite	14.1	15.8	17.2	21.1

Post-Project Conditions

Post-Project Development

The site will be developed as a single commercial lot, with access to Maple Street and the existing commercial parking lot to the west.

Post-Project Landform and Slope

The existing pond will be filled and a new pond will be constructed in the southern portion of the site. The site will be graded so that the water flows from north to south. Post-Project slopes will range from 0.5% to 2.0%. The Lot Grading Plan is in Appendix E. Stormwater sewer (SWS) will route runoff from the site into the proposed detention pond. The Drainage and Utility Plan, Appendix F, shows proposed utilities and the detention pond location.

Post-Project Runoff Characteristics

An 18" RCP will act as the outlet structure for the proposed pond. This RCP will route runoff from the proposed pond to the existing 2-15" pipes crossing under Maple Street. An inlet will be constructed to connect the two systems. Approximately 0.5 acres will be allowed to exit the site without detention via the proposed inlet. A ditch will be constructed along the east property line of the site and serve as an emergency spillway. This ditch will route the runoff from the residential development east of the site directly to Maple Street. Once on Maple Street the runoff will flow to a nearby inlet draining into the existing pond northeast of the site. The ditch was designed to handle the flow for 1 cfs/acre of land tributary to the pond and the 100-yr flow from the residential property to the east. Calculations for the ditch were completed using Flowmaster, Appendix G. Post-project conditions were modeled using Hydraflow Hydrographs by Intelisolve, Appendix H. The site was divided into sub-watersheds to size the SWS. The sub-watersheds are shown in the Drainage and Utility Plan, Appendix F. The SWS was sized using the Rational Method, the time of concentration to each inlet was determined using the FAA Method, Appendix I. A summary of the post-project flows is located in Table 1.

Table 2. Post-Project runoff.

	2-Year	5-Year	10-Year	100-Year
Flow to Pond	58.9	69.6	79.9	112.7
Flow out of Pond (18" RCP)	7.5	8.7	9.6	12.1
Sheet Flow to 2-15" PVC	1.8	2.2	2.5	3.5
Total Flow to 2-15" PVC	8.0	9.2	10.3	13.2
To Maple from Residential	3.4	4.0	4.6	6.5
Total Flow Offsite	9.7	11.5	13.1	17.9

Runoff flowing onto Maple Street under Post-Project conditions increases by 6.5 cfs during a 100-year event. The total runoff rate leaving the site is decreased during all storm events. Since all runoff leaving the site flows to the same offsite detention pond, the changes in routing will have minor impacts on the watershed.

Summary

The Auburn Hills Commercial 4th Addition is approximately 4.6 acres located east of 135th Street West and south of Maple Street. This site was previously platted as Auburn Hills Commercial 3rd Addition. An existing pond on-site provides detention for Auburn Hills Commercial Addition and a portion of Auburn Hills Residential Addition. When the site develops, the pond will be replaced with a new pond in reserve on the south side of the property. An emergency spillway for the pond will be located along the east property line. This spillway will divert the runoff from the residential property east of the site directly into Maple Street without detention. Runoff from the pond will be routed via 18" RCP into an inlet on the north side of the property encasing the existing 2-15" PVC. The total runoff leaving the site decreases when compared to the Auburn Hills Commercial 3rd Drainage Plan.

Appendix A

Quadrangle

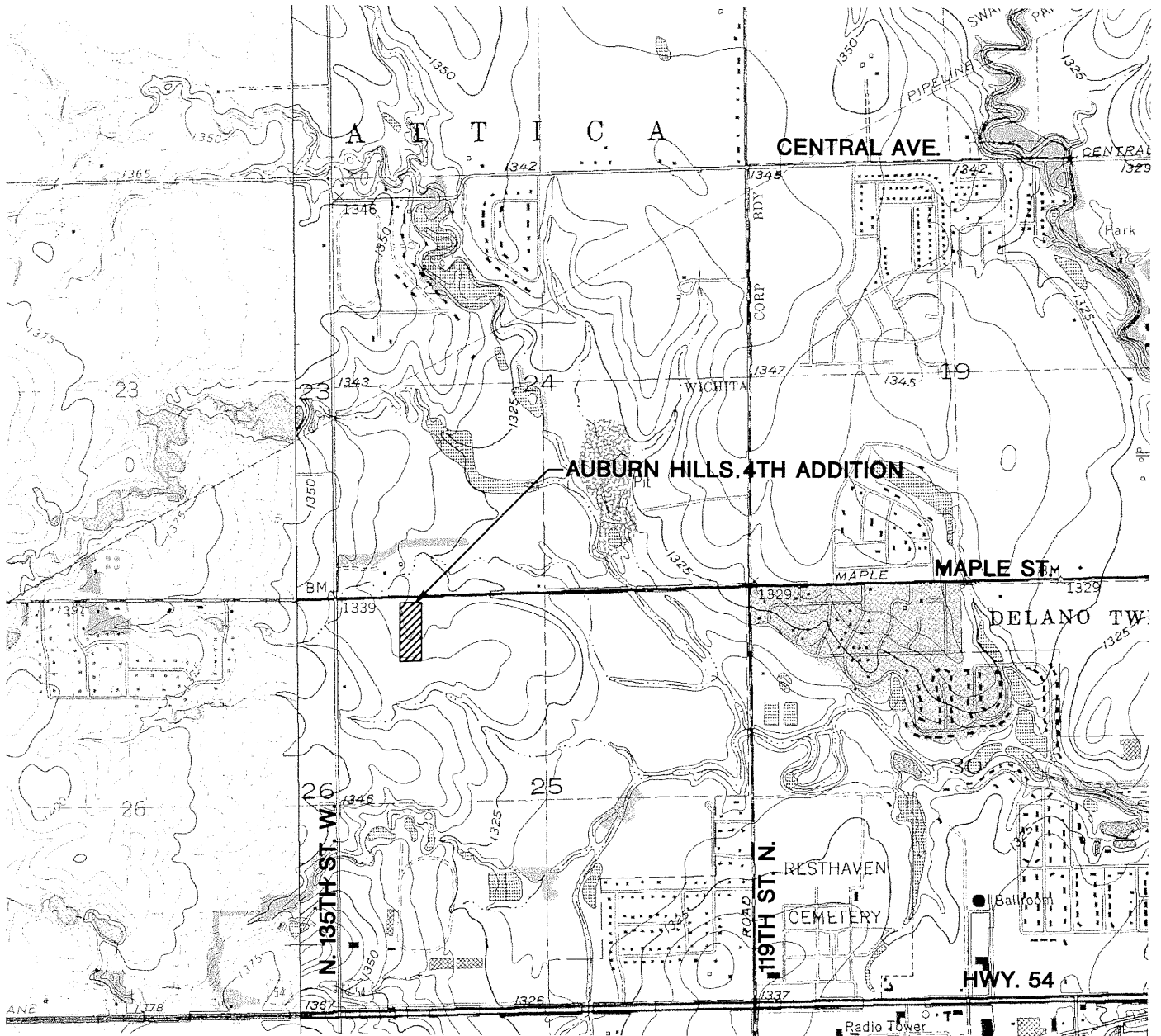

SCALE 1:24 000

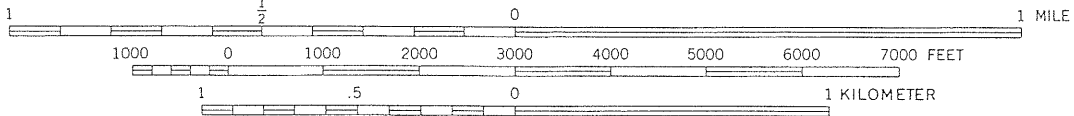

CONTOUR INTERVAL 5 FEET
NATIONAL GEODETIC VERTICAL DATUM OF 1929



J:\CIVIL\05403\DWG\DRNG\USGS.DWG

MKEC
ENGINEERING
CONSULTANTS
411 N. WEBB ROAD
WICHITA, KS. 67206
316 - 684 - 9600

AUBURN HILLS 4TH ADDITION
PROJECT NAME
USGS GEOLOGICAL SURVEY
WICHITA WEST, KANSAS QUANRANGLE
SHEET TITLE

AJK DESIGN BY:	KWS DRAWN BY:	GJA CHECKED BY:
AUGUST 2005 DATE	05403 JOB NO.	1 / 1 SHEET/OF

Appendix B

Soil Survey

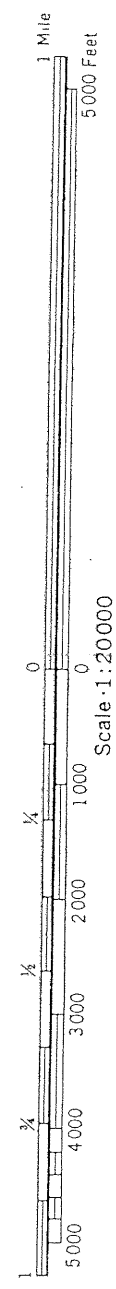
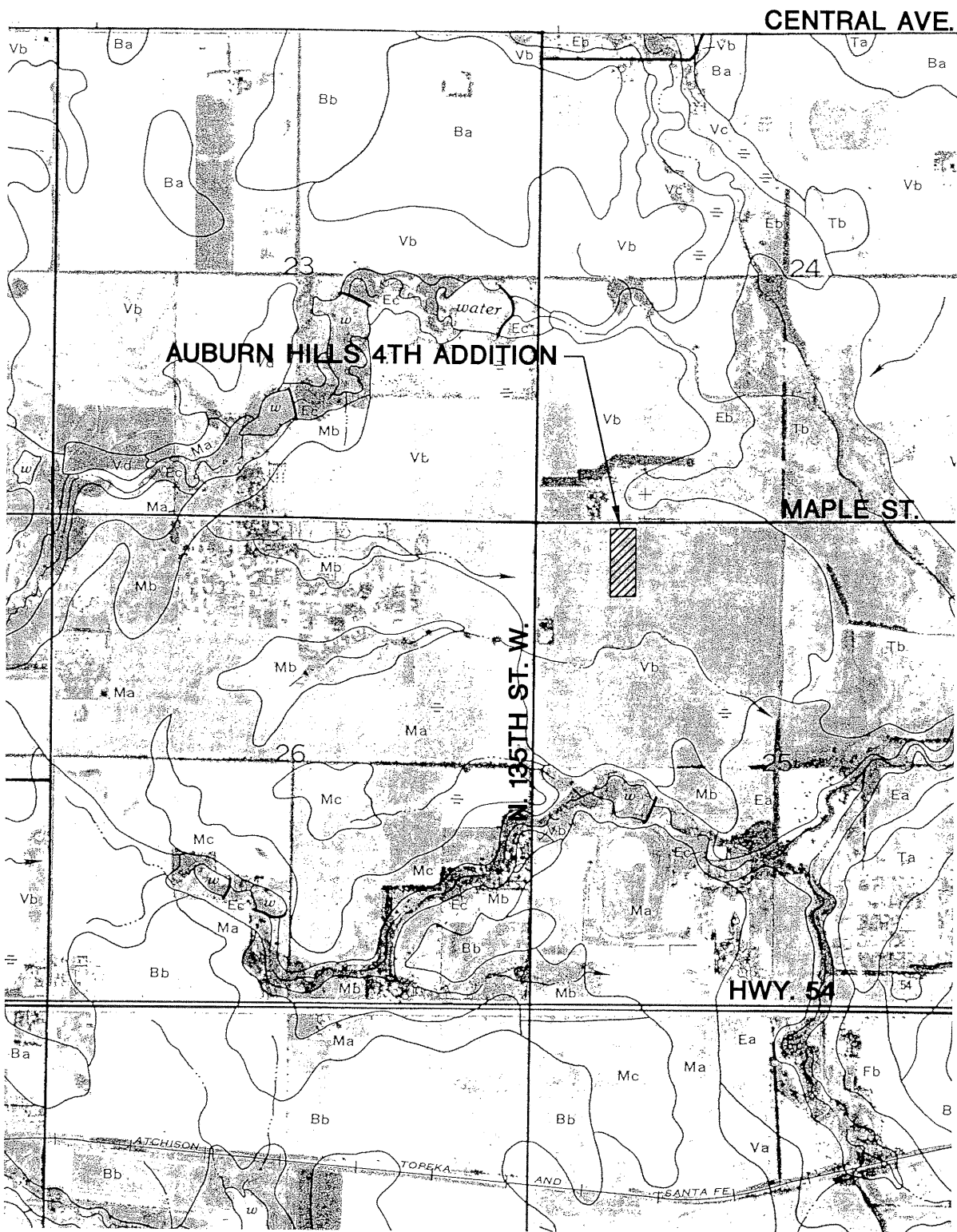

J:\CIVIL\05403\DWG\DRWG\SOLL.DWG



AUBURN HILL 4TH ADDITION
 PROJECT NAME
SOIL SURVEY
SEDGWICK COUNTY, KANSAS
 SHEET TITLE

AJK	KWS	GJA
DESIGN BY:	DRAWN BY:	CHECKED BY:
AUGUST 2005	05403	1 / 1
DATE	JOB NO.	SHEET/OF

Appendix C
FIRM & FBFM

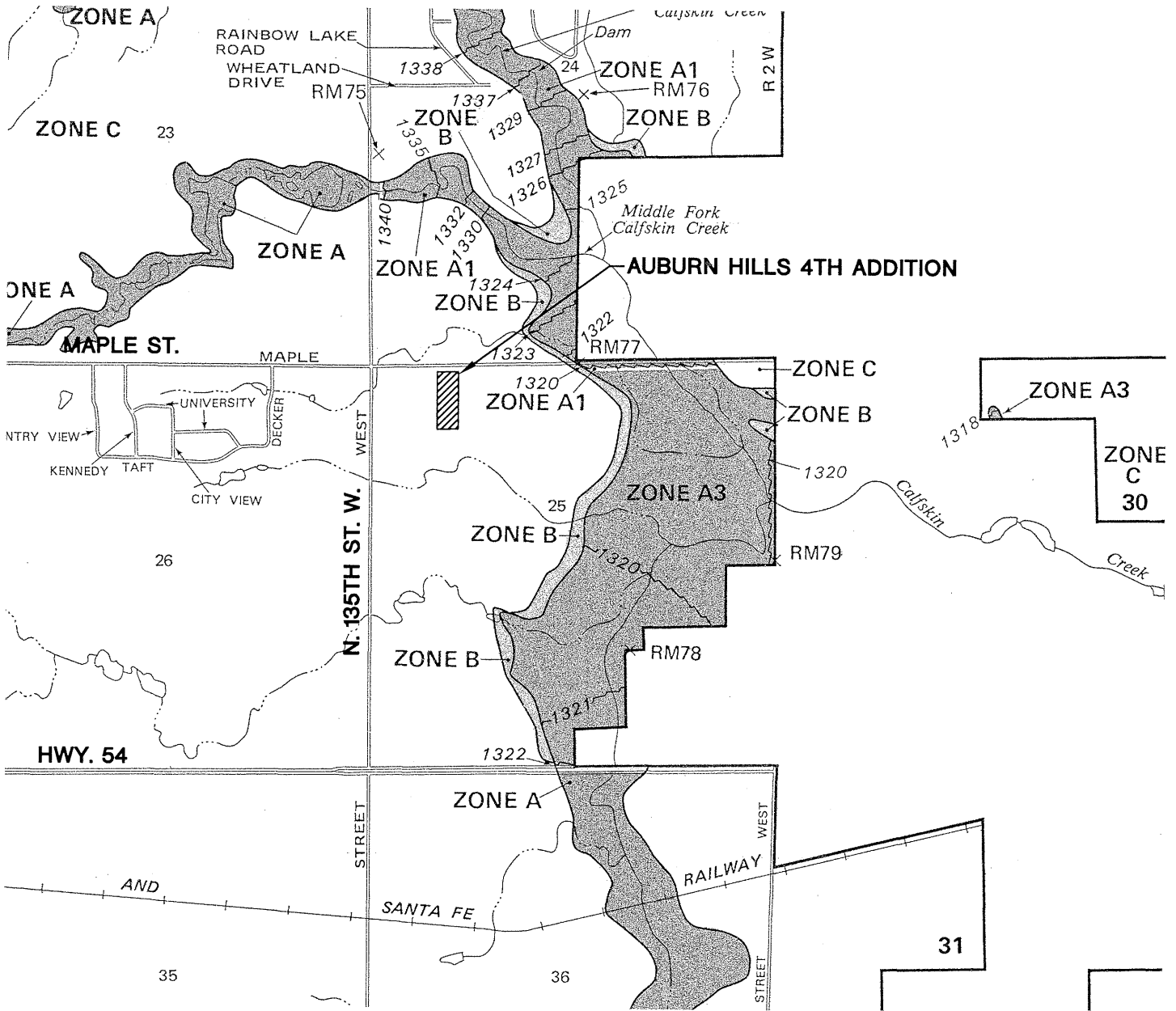

NATIONAL FLOOD INSURANCE PROGRAM

FIRM
FLOOD INSURANCE RATE MAP

SEDGWICK COUNTY,
KANSAS
(UNINCORPORATED AREAS)

PANEL 200 OF 300

COMMUNITY-PANEL NUMBER
200321 0200 A

EFFECTIVE DATE:
JUNE 3, 1986



Federal Emergency Management Agency

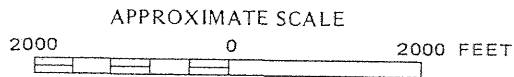

MKEC
ENGINEERING CONSULTANTS
411 N. WEBB ROAD
WICHITA, KS. 67206
316 - 684 - 9600

AUBURN HILL 4TH ADDITION

PROJECT NAME

**FLOOD INSURANCE RATE MAP
SEDGWICK COUNTY, KANSAS**

SHEET TITLE

AJK

DESIGN BY:

KWS

DRAWN BY:

GJA

CHECKED BY:

AUGUST 2005

DATE

104094

JOB NO.

1 / 1

SHEET/OF

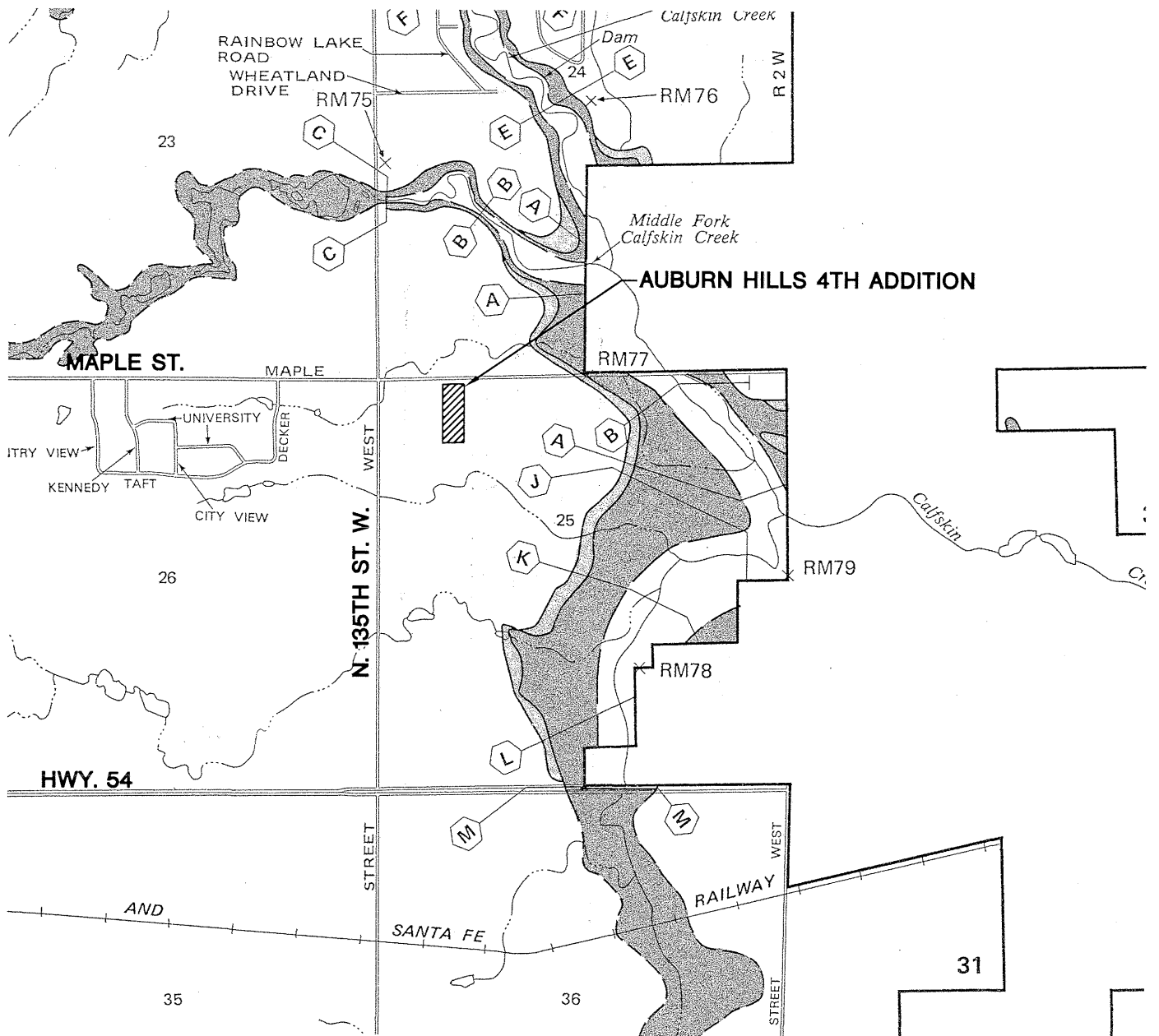

NATIONAL FLOOD INSURANCE PROGRAM

FLOODWAY
FLOOD BOUNDARY AND
FLOODWAY MAP

SEDGWICK
COUNTY,
KANSAS
(UNINCORPORATED AREAS)

PANEL 200 OF 300
(SEE MAP INDEX FOR PANELS NOT PRINTED)

COMMUNITY-PANEL NUMBER
200321 0200

EFFECTIVE DATE:
JUNE 3, 1986



Federal Emergency Management Agency

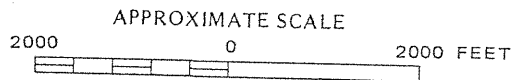

J:\CIVIL\05403\DWG\DRNG\FBFM.DWG

MKEC
ENGINEERING
CONSULTANTS
411 N. WEBB ROAD
WICHITA, KS. 67206
316 - 684 - 9600

AUBURN HILL 4TH ADDITION
PROJECT NAME

FLOOD BOUNDARY AND FLOODWAY MAP
SHEET TITLE

AJK DESIGN BY:	KWS DRAWN BY:	GJA CHECKED BY:
AUGUST 2005 DATE	04503 JOB NO.	1 / 1 SHEET/OF

Appendix D
Existing Hydraflow Hydrographs
By Intelisolve
Output

Hydrograph Return Period Recap

Hyd. No.	Hydrograph type (origin)	Inflow Hyd(s)	Peak Outflow (cfs)								Hydrograph description
			1-Yr	2-Yr	3-Yr	5-Yr	10-Yr	25-Yr	50-Yr	100-Yr	
1	Rational	-----	-----	44.44	-----	52.53	60.29	-----	-----	85.05	West
2	Rational	-----	-----	16.25	-----	19.21	22.04	-----	-----	31.10	Mid
3	Rational	-----	-----	3.38	-----	3.99	4.58	-----	-----	6.46	East
4	Combine	1, 2, 3	-----	64.07	-----	75.73	86.92	-----	-----	122.61	Into Pond
5	Reservoir	4	-----	14.11	-----	15.78	17.21	-----	-----	21.05	Existing Pond

Proj. file: Exist. Pond Calcs.gpw

Run date: 09-22-2005

Hydrograph Summary Report

Hyd. No.	Hydrograph type (origin)	Peak flow (cfs)	Time interval (min)	Time to peak (min)	Volume (acft)	Inflow hyd(s)	Maximum elevation (ft)	Maximum storage (acft)	Hydrograph description	
1	Rational	44.44	1	15	0.918	---	----	----	West	
2	Rational	16.25	1	15	0.336	---	----	----	Mid	
3	Rational	3.38	1	15	0.070	---	----	----	East	
4	Combine	64.07	1	15	1.324	1, 2, 3	----	----	Into Pond	
5	Reservoir	14.11	1	27	1.315	4	139.75	1.034	Existing Pond	
Proj. file: Exist. Pond Calcs.gpw				Return Period: 2 yr				Run date: 09-22-2005		

Hydrograph Summary Report

Hyd. No.	Hydrograph type (origin)	Peak flow (cfs)	Time interval (min)	Time to peak (min)	Volume (acft)	Inflow hyd(s)	Maximum elevation (ft)	Maximum storage (acft)	Hydrograph description	
1	Rational	52.53	1	15	1.085	---	----	----	West	
2	Rational	19.21	1	15	0.397	---	----	----	Mid	
3	Rational	3.99	1	15	0.082	---	----	----	East	
4	Combine	75.73	1	15	1.565	1, 2, 3	----	----	Into Pond	
5	Reservoir	15.78	1	27	1.556	4	140.11	1.232	Existing Pond	
Proj. file: Exist. Pond Calcs.gpw				Return Period: 5 yr				Run date: 09-22-2005		

Hydrograph Summary Report

Hyd. No.	Hydrograph type (origin)	Peak flow (cfs)	Time interval (min)	Time to peak (min)	Volume (acft)	Inflow hyd(s)	Maximum elevation (ft)	Maximum storage (acft)	Hydrograph description	
1	Rational	60.29	1	15	1.246	---	----	----	West	
2	Rational	22.04	1	15	0.455	---	----	----	Mid	
3	Rational	4.58	1	15	0.095	---	----	----	East	
4	Combine	86.92	1	15	1.796	1, 2, 3	----	----	Into Pond	
5	Reservoir	17.21	1	27	1.787	4	140.45	1.424	Existing Pond	
Proj. file: Exist. Pond Calcs.gpw				Return Period: 10 yr				Run date: 09-22-2005		

Hydrograph Summary Report

Hyd. No.	Hydrograph type (origin)	Peak flow (cfs)	Time interval (min)	Time to peak (min)	Volume (acft)	Inflow hyd(s)	Maximum elevation (ft)	Maximum storage (acft)	Hydrograph description	
1	Rational	85.05	1	15	1.757	---	----	----	West	
2	Rational	31.10	1	15	0.643	---	----	----	Mid	
3	Rational	6.46	1	15	0.134	---	----	----	East	
4	Combine	122.61	1	15	2.533	1, 2, 3	----	----	Into Pond	
5	Reservoir	21.05	1	27	2.524	4	141.50	2.055	Existing Pond	
Proj. file: Exist. Pond Calcs.gpw				Return Period: 100 yr				Run date: 09-22-2005		

Hydrograph Report

Hyd. No. 1

West

Hydrograph type	= Rational	Peak discharge	= 85.05 cfs
Storm frequency	= 100 yrs	Time interval	= 1 min
Drainage area	= 12.7 ac	Runoff coeff.	= 0.91
Intensity	= 7.365 in/hr	Time of conc. (Tc)	= 15 min
IDF Curve	= SedgwickCoKS.IDF	Asc/Rec limb fact	= 1/1

Hydrograph Volume = 1.757 acft

Hydrograph Discharge Table

Time -- Outflow
(hrs cfs)

0.05	17.01
0.07	22.68
0.08	28.35
0.10	34.02
0.12	39.69
0.13	45.36
0.15	51.03
0.17	56.70
0.18	62.37
0.20	68.04
0.22	73.71
0.23	79.38
0.25	85.05 <<
0.27	79.38
0.28	73.71
0.30	68.04
0.32	62.37
0.33	56.70
0.35	51.03
0.37	45.36
0.38	39.69
0.40	34.02
0.42	28.35
0.43	22.68

...End

Hydrograph Report

Hyd. No. 2

Mid

Hydrograph type	= Rational	Peak discharge	= 31.10 cfs
Storm frequency	= 100 yrs	Time interval	= 1 min
Drainage area	= 4.6 ac	Runoff coeff.	= 0.91
Intensity	= 7.365 in/hr	Time of conc. (Tc)	= 15 min
IDF Curve	= SedgwickCoKS.IDF	Asc/Rec limb fact	= 1/1

Hydrograph Volume = 0.643 acft

Hydrograph Discharge Table

Time -- Outflow
(hrs cfs)

0.05	6.22
0.07	8.29
0.08	10.37
0.10	12.44
0.12	14.51
0.13	16.59
0.15	18.66
0.17	20.73
0.18	22.81
0.20	24.88
0.22	26.95
0.23	29.03
0.25	31.10 <<
0.27	29.03
0.28	26.95
0.30	24.88
0.32	22.81
0.33	20.73
0.35	18.66
0.37	16.59
0.38	14.51
0.40	12.44
0.42	10.37
0.43	8.29
0.45	6.22

...End

Hydrograph Report

Hyd. No. 3

East

Hydrograph type	= Rational	Peak discharge	= 6.46 cfs
Storm frequency	= 100 yrs	Time interval	= 1 min
Drainage area	= 1.4 ac	Runoff coeff.	= 0.65
Intensity	= 7.365 in/hr	Time of conc. (Tc)	= 15 min
IDF Curve	= SedgwickCoKS.IDF	Asc/Rec limb fact	= 1/1

Hydrograph Volume = 0.134 acft

Hydrograph Discharge Table

Time -- Outflow
(hrs cfs)

0.05	1.29
0.07	1.72
0.08	2.15
0.10	2.59
0.12	3.02
0.13	3.45
0.15	3.88
0.17	4.31
0.18	4.74
0.20	5.17
0.22	5.60
0.23	6.03
0.25	6.46 <<
0.27	6.03
0.28	5.60
0.30	5.17
0.32	4.74
0.33	4.31
0.35	3.88
0.37	3.45
0.38	3.02
0.40	2.59
0.42	2.15
0.43	1.72

...End

Hydrograph Report

Hyd. No. 4

Into Pond

Hydrograph type = Combine
Storm frequency = 100 yrs
Inflow hyds. = 1, 2, 3

Peak discharge = 122.61 cfs
Time interval = 1 min

Hydrograph Volume = 2.533 acft

Hydrograph Discharge Table

Time (hrs)	Hyd. 1 + (cfs)	Hyd. 2 + (cfs)	Hyd. 3 = (cfs)	Outflow (cfs)
0.05	17.01	6.22	1.29	24.52
0.07	22.68	8.29	1.72	32.70
0.08	28.35	10.37	2.15	40.87
0.10	34.02	12.44	2.59	49.04
0.12	39.69	14.51	3.02	57.22
0.13	45.36	16.59	3.45	65.39
0.15	51.03	18.66	3.88	73.57
0.17	56.70	20.73	4.31	81.74
0.18	62.37	22.81	4.74	89.92
0.20	68.04	24.88	5.17	98.09
0.22	73.71	26.95	5.60	106.26
0.23	79.38	29.03	6.03	114.44
0.25	85.05 <<	31.10 <<	6.46 <<	122.61 <<
0.27	79.38	29.03	6.03	114.44
0.28	73.71	26.95	5.60	106.26
0.30	68.04	24.88	5.17	98.09
0.32	62.37	22.81	4.74	89.92
0.33	56.70	20.73	4.31	81.74
0.35	51.03	18.66	3.88	73.57
0.37	45.36	16.59	3.45	65.39
0.38	39.69	14.51	3.02	57.22
0.40	34.02	12.44	2.59	49.04
0.42	28.35	10.37	2.15	40.87
0.43	22.68	8.29	1.72	32.70

...End

Hydrograph Report

Hyd. No. 5

Existing Pond

Hydrograph type = Reservoir
 Storm frequency = 100 yrs
 Inflow hyd. No. = 4
 Max. Elevation = 141.50 ft

Peak discharge = 21.05 cfs
 Time interval = 1 min
 Reservoir name = Existing Pond
 Max. Storage = 2.055 acft

Storage Indication method used.

Outflow hydrograph volume = 2.524 acft

Hydrograph Discharge Table

Time (hrs)	Inflow cfs	Elevation ft	Clv A cfs	Clv B cfs	Clv C cfs	Clv D cfs	Wr A cfs	Wr B cfs	Wr C cfs	Wr D cfs	Exfil cfs	Outflow cfs
0.13	65.39	138.43	4.37	----	----	----	----	----	----	----	----	4.37
0.15	73.57	138.61	6.27	----	----	----	----	----	----	----	----	6.27
0.17	81.74	138.80	8.19	----	----	----	----	----	----	----	----	8.19
0.18	89.92	139.01	9.77	----	----	----	----	----	----	----	----	9.77
0.20	98.09	139.23	11.24	----	----	----	----	----	----	----	----	11.24
0.22	106.26	139.46	12.62	----	----	----	----	----	----	----	----	12.62
0.23	114.44	139.71	13.92	----	----	----	----	----	----	----	----	13.92
0.25	122.61 <<	139.97	15.17	----	----	----	----	----	----	----	----	15.17
0.27	114.44	140.22	16.29	----	----	----	----	----	----	----	----	16.29
0.28	106.26	140.45	17.23	----	----	----	----	----	----	----	----	17.23
0.30	98.09	140.65	18.02	----	----	----	----	----	----	----	----	18.02
0.32	89.92	140.83	18.69	----	----	----	----	----	----	----	----	18.69
0.33	81.74	140.98	19.26	----	----	----	----	----	----	----	----	19.26
0.35	73.57	141.11	19.74	----	----	----	----	----	----	----	----	19.74
0.37	65.39	141.23	20.13	----	----	----	----	----	----	----	----	20.13
0.38	57.22	141.32	20.45	----	----	----	----	----	----	----	----	20.45
0.40	49.04	141.39	20.69	----	----	----	----	----	----	----	----	20.69
0.42	40.87	141.45	20.87	----	----	----	----	----	----	----	----	20.87
0.43	32.70	141.48	20.99	----	----	----	----	----	----	----	----	20.99
0.45	24.52	141.50 <<	21.05	----	----	----	----	----	----	----	----	21.05 <<
0.47	16.35	141.50	21.04	----	----	----	----	----	----	----	----	21.04
0.48	8.17	141.48	20.98	----	----	----	----	----	----	----	----	20.98
0.50	0.00	141.44	20.85	----	----	----	----	----	----	----	----	20.85
0.52	0.00	141.39	20.70	----	----	----	----	----	----	----	----	20.70
0.53	0.00	141.35	20.54	----	----	----	----	----	----	----	----	20.54
0.55	0.00	141.30	20.39	----	----	----	----	----	----	----	----	20.39
0.57	0.00	141.26	20.23	----	----	----	----	----	----	----	----	20.23
0.58	0.00	141.21	20.07	----	----	----	----	----	----	----	----	20.07
0.60	0.00	141.17	19.91	----	----	----	----	----	----	----	----	19.91
0.62	0.00	141.12	19.76	----	----	----	----	----	----	----	----	19.76
0.63	0.00	141.08	19.60	----	----	----	----	----	----	----	----	19.60
0.65	0.00	141.03	19.44	----	----	----	----	----	----	----	----	19.44
0.67	0.00	140.99	19.28	----	----	----	----	----	----	----	----	19.28
0.68	0.00	140.94	19.12	----	----	----	----	----	----	----	----	19.12
0.70	0.00	140.90	18.96	----	----	----	----	----	----	----	----	18.96
0.72	0.00	140.85	18.79	----	----	----	----	----	----	----	----	18.79
0.73	0.00	140.81	18.63	----	----	----	----	----	----	----	----	18.63
0.75	0.00	140.77	18.47	----	----	----	----	----	----	----	----	18.47

Continues on next page...

Hydrograph Discharge Table

Time (hrs)	Inflow cfs	Elevation ft	Clv A cfs	Clv B cfs	Clv C cfs	Clv D cfs	Wr A cfs	Wr B cfs	Wr C cfs	Wr D cfs	Exfil cfs	Outflow cfs
0.77	0.00	140.73	18.31	----	----	----	----	----	----	----	----	18.31
0.78	0.00	140.68	18.14	----	----	----	----	----	----	----	----	18.14
0.80	0.00	140.64	17.98	----	----	----	----	----	----	----	----	17.98
0.82	0.00	140.60	17.81	----	----	----	----	----	----	----	----	17.81
0.83	0.00	140.56	17.65	----	----	----	----	----	----	----	----	17.65
0.85	0.00	140.51	17.48	----	----	----	----	----	----	----	----	17.48
0.87	0.00	140.47	17.32	----	----	----	----	----	----	----	----	17.32
0.88	0.00	140.43	17.15	----	----	----	----	----	----	----	----	17.15
0.90	0.00	140.39	16.98	----	----	----	----	----	----	----	----	16.98
0.92	0.00	140.35	16.82	----	----	----	----	----	----	----	----	16.82
0.93	0.00	140.31	16.65	----	----	----	----	----	----	----	----	16.65
0.95	0.00	140.27	16.48	----	----	----	----	----	----	----	----	16.48
0.97	0.00	140.23	16.31	----	----	----	----	----	----	----	----	16.31
0.98	0.00	140.19	16.14	----	----	----	----	----	----	----	----	16.14
1.00	0.00	140.15	15.97	----	----	----	----	----	----	----	----	15.97
1.02	0.00	140.11	15.80	----	----	----	----	----	----	----	----	15.80
1.03	0.00	140.07	15.63	----	----	----	----	----	----	----	----	15.63
1.05	0.00	140.04	15.46	----	----	----	----	----	----	----	----	15.46
1.07	0.00	140.00	15.28	----	----	----	----	----	----	----	----	15.28
1.08	0.00	139.96	15.11	----	----	----	----	----	----	----	----	15.11
1.10	0.00	139.92	14.94	----	----	----	----	----	----	----	----	14.94
1.12	0.00	139.89	14.76	----	----	----	----	----	----	----	----	14.76
1.13	0.00	139.85	14.59	----	----	----	----	----	----	----	----	14.59
1.15	0.00	139.81	14.41	----	----	----	----	----	----	----	----	14.41
1.17	0.00	139.78	14.24	----	----	----	----	----	----	----	----	14.24
1.18	0.00	139.74	14.06	----	----	----	----	----	----	----	----	14.06
1.20	0.00	139.71	13.89	----	----	----	----	----	----	----	----	13.89
1.22	0.00	139.67	13.71	----	----	----	----	----	----	----	----	13.71
1.23	0.00	139.64	13.53	----	----	----	----	----	----	----	----	13.53
1.25	0.00	139.60	13.35	----	----	----	----	----	----	----	----	13.35
1.27	0.00	139.57	13.18	----	----	----	----	----	----	----	----	13.18
1.28	0.00	139.54	13.00	----	----	----	----	----	----	----	----	13.00
1.30	0.00	139.50	12.82	----	----	----	----	----	----	----	----	12.82
1.32	0.00	139.47	12.64	----	----	----	----	----	----	----	----	12.64
1.33	0.00	139.44	12.46	----	----	----	----	----	----	----	----	12.46
1.35	0.00	139.40	12.28	----	----	----	----	----	----	----	----	12.28
1.37	0.00	139.37	12.10	----	----	----	----	----	----	----	----	12.10
1.38	0.00	139.34	11.92	----	----	----	----	----	----	----	----	11.92
1.40	0.00	139.31	11.74	----	----	----	----	----	----	----	----	11.74
1.42	0.00	139.28	11.55	----	----	----	----	----	----	----	----	11.55
1.43	0.00	139.25	11.37	----	----	----	----	----	----	----	----	11.37
1.45	0.00	139.22	11.19	----	----	----	----	----	----	----	----	11.19
1.47	0.00	139.19	11.00	----	----	----	----	----	----	----	----	11.00
1.48	0.00	139.16	10.82	----	----	----	----	----	----	----	----	10.82
1.50	0.00	139.13	10.63	----	----	----	----	----	----	----	----	10.63
1.52	0.00	139.11	10.45	----	----	----	----	----	----	----	----	10.45
1.53	0.00	139.08	10.26	----	----	----	----	----	----	----	----	10.26
1.55	0.00	139.05	10.08	----	----	----	----	----	----	----	----	10.08
1.57	0.00	139.03	9.89	----	----	----	----	----	----	----	----	9.89
1.58	0.00	139.00	9.70	----	----	----	----	----	----	----	----	9.70
1.60	0.00	138.97	9.52	----	----	----	----	----	----	----	----	9.52

Continues on next page...

Hydrograph Discharge Table

Time (hrs)	Inflow cfs	Elevation ft	Clv A cfs	Clv B cfs	Clv C cfs	Clv D cfs	Wr A cfs	Wr B cfs	Wr C cfs	Wr D cfs	Exfil cfs	Outflow cfs
1.62	0.00	138.95	9.35	----	----	----	----	----	----	----	----	9.35
1.63	0.00	138.92	9.21	----	----	----	----	----	----	----	----	9.21
1.65	0.00	138.90	9.04	----	----	----	----	----	----	----	----	9.04
1.67	0.00	138.88	8.85	----	----	----	----	----	----	----	----	8.85
1.68	0.00	138.85	8.67	----	----	----	----	----	----	----	----	8.67
1.70	0.00	138.83	8.47	----	----	----	----	----	----	----	----	8.47
1.72	0.00	138.81	8.23	----	----	----	----	----	----	----	----	8.23
1.73	0.00	138.78	8.03	----	----	----	----	----	----	----	----	8.03
1.75	0.00	138.76	7.84	----	----	----	----	----	----	----	----	7.84
1.77	0.00	138.74	7.64	----	----	----	----	----	----	----	----	7.64
1.78	0.00	138.72	7.45	----	----	----	----	----	----	----	----	7.45
1.80	0.00	138.70	7.25	----	----	----	----	----	----	----	----	7.25
1.82	0.00	138.68	7.05	----	----	----	----	----	----	----	----	7.05
1.83	0.00	138.66	6.85	----	----	----	----	----	----	----	----	6.85
1.85	0.00	138.64	6.65	----	----	----	----	----	----	----	----	6.65
1.87	0.00	138.62	6.45	----	----	----	----	----	----	----	----	6.45
1.88	0.00	138.61	6.25	----	----	----	----	----	----	----	----	6.25
1.90	0.00	138.59	6.06	----	----	----	----	----	----	----	----	6.06
1.92	0.00	138.57	5.87	----	----	----	----	----	----	----	----	5.87
1.93	0.00	138.56	5.69	----	----	----	----	----	----	----	----	5.69
1.95	0.00	138.54	5.51	----	----	----	----	----	----	----	----	5.51
1.97	0.00	138.53	5.44	----	----	----	----	----	----	----	----	5.44
1.98	0.00	138.51	5.32	----	----	----	----	----	----	----	----	5.32
2.00	0.00	138.50	5.16	----	----	----	----	----	----	----	----	5.16
2.02	0.00	138.48	4.99	----	----	----	----	----	----	----	----	4.99
2.03	0.00	138.47	4.83	----	----	----	----	----	----	----	----	4.83
2.05	0.00	138.46	4.67	----	----	----	----	----	----	----	----	4.67
2.07	0.00	138.44	4.52	----	----	----	----	----	----	----	----	4.52
2.08	0.00	138.43	4.38	----	----	----	----	----	----	----	----	4.38
2.10	0.00	138.42	4.25	----	----	----	----	----	----	----	----	4.25
2.12	0.00	138.41	4.21	----	----	----	----	----	----	----	----	4.21

...End

Reservoir Report

Reservoir No. 1 - Existing Pond

Hydraflow Hydrographs by Intelisolve

Pond Data

Bottom LxW = 142.0 x 142.0 ft Side slope = 3.0:1 Bottom elev. = 137.70 ft Depth = 4.00 ft

Stage / Storage Table

Stage (ft)	Elevation (ft)	Contour area (sqft)	Incr. Storage (acft)	Total storage (acft)
0.00	137.70	20,164	0.000	0.000
0.20	137.90	20,506	0.093	0.093
0.40	138.10	20,851	0.095	0.188
0.60	138.30	21,199	0.097	0.285
0.80	138.50	21,550	0.098	0.383
1.00	138.70	21,904	0.100	0.483
1.20	138.90	22,261	0.101	0.584
1.40	139.10	22,620	0.103	0.687
1.60	139.30	22,983	0.105	0.792
1.80	139.50	23,348	0.106	0.898
2.00	139.70	23,716	0.108	1.006
2.20	139.90	24,087	0.110	1.116
2.40	140.10	24,461	0.111	1.227
2.60	140.30	24,838	0.113	1.341
2.80	140.50	25,217	0.115	1.456
3.00	140.70	25,600	0.117	1.572
3.20	140.90	25,985	0.118	1.691
3.40	141.10	26,374	0.120	1.811
3.60	141.30	26,765	0.122	1.933
3.80	141.50	27,159	0.124	2.057
4.00	141.70	27,556	0.126	2.182

Culvert / Orifice Structures

	[A]	[B]	[C]	[D]
Rise in	= 15.0	0.0	0.0	0.0
Span in	= 15.0	0.0	0.0	0.0
No. Barrels	= 2	0	0	0
Invert El. ft	= 137.70	0.00	0.00	0.00
Length ft	= 0.0	0.0	0.0	0.0
Slope %	= 0.00	0.00	0.00	0.00
N-Value	= .011	.000	.000	.000
Orif. Coeff.	= 0.60	0.00	0.00	0.00
Multi-Stage	= n/a	No	No	No

Weir Structures

	[A]	[B]	[C]	[D]
Crest Len ft	= 0.00	0.00	0.00	0.00
Crest El. ft	= 0.00	0.00	0.00	0.00
Weir Coeff.	= 0.00	0.00	0.00	0.00
Weir Type	= ---	---	---	---
Multi-Stage	= No	No	No	No

Exfiltration Rate = 0.00 in/hr/sqft Tailwater Elev. = 0.00 ft

Note: All outflows have been analyzed under inlet and outlet control.

Stage / Storage / Discharge Table

Stage ft	Storage acft	Elevation ft	Civ A cfs	Civ B cfs	Civ C cfs	Civ D cfs	Wr A cfs	Wr B cfs	Wr C cfs	Wr D cfs	Exfil cfs	Total cfs
0.00	0.000	137.70	0.00	---	---	---	---	---	---	---	---	0.00
0.02	0.009	137.72	0.01	---	---	---	---	---	---	---	---	0.01
0.04	0.019	137.74	0.02	---	---	---	---	---	---	---	---	0.02
0.06	0.028	137.76	0.04	---	---	---	---	---	---	---	---	0.04
0.08	0.037	137.78	0.08	---	---	---	---	---	---	---	---	0.08
0.10	0.047	137.80	0.11	---	---	---	---	---	---	---	---	0.11
0.12	0.056	137.82	0.17	---	---	---	---	---	---	---	---	0.17
0.14	0.065	137.84	0.21	---	---	---	---	---	---	---	---	0.21
0.16	0.075	137.86	0.26	---	---	---	---	---	---	---	---	0.26
0.18	0.084	137.88	0.32	---	---	---	---	---	---	---	---	0.32
0.20	0.093	137.90	0.39	---	---	---	---	---	---	---	---	0.39
0.22	0.103	137.92	0.52	---	---	---	---	---	---	---	---	0.52
0.24	0.112	137.94	0.61	---	---	---	---	---	---	---	---	0.61
0.26	0.122	137.96	0.71	---	---	---	---	---	---	---	---	0.71
0.28	0.131	137.98	0.81	---	---	---	---	---	---	---	---	0.81
0.30	0.141	138.00	0.92	---	---	---	---	---	---	---	---	0.92
0.32	0.150	138.02	1.05	---	---	---	---	---	---	---	---	1.05

Continues on next page...

1.72

0.856

139.42

12.36

12.36

Continues on next page...

3.12 1.643 140.82 18.66 --- --- --- --- --- --- --- --- 18.66

Continues on next page...

Stage / Storage / Discharge Table

Stage ft	Storage acft	Elevation ft	Clv A cfs	Clv B cfs	Clv C cfs	Clv D cfs	Wr A cfs	Wr B cfs	Wr C cfs	Wr D cfs	Exfil cfs	Total cfs
3.14	1.655	140.84	18.74	---	---	---	---	---	---	---	---	18.74
3.16	1.667	140.86	18.81	---	---	---	---	---	---	---	---	18.81
3.18	1.679	140.88	18.89	---	---	---	---	---	---	---	---	18.89
3.20	1.691	140.90	18.96	---	---	---	---	---	---	---	---	18.96
3.22	1.703	140.92	19.03	---	---	---	---	---	---	---	---	19.03
3.24	1.715	140.94	19.11	---	---	---	---	---	---	---	---	19.11
3.26	1.727	140.96	19.18	---	---	---	---	---	---	---	---	19.18
3.28	1.739	140.98	19.25	---	---	---	---	---	---	---	---	19.25
3.30	1.751	141.00	19.33	---	---	---	---	---	---	---	---	19.33
3.32	1.763	141.02	19.40	---	---	---	---	---	---	---	---	19.40
3.34	1.775	141.04	19.47	---	---	---	---	---	---	---	---	19.47
3.36	1.787	141.06	19.54	---	---	---	---	---	---	---	---	19.54
3.38	1.799	141.08	19.61	---	---	---	---	---	---	---	---	19.61
3.40	1.811	141.10	19.68	---	---	---	---	---	---	---	---	19.68
3.42	1.823	141.12	19.75	---	---	---	---	---	---	---	---	19.75
3.44	1.835	141.14	19.83	---	---	---	---	---	---	---	---	19.83
3.46	1.847	141.16	19.90	---	---	---	---	---	---	---	---	19.90
3.48	1.860	141.18	19.97	---	---	---	---	---	---	---	---	19.97
3.50	1.872	141.20	20.04	---	---	---	---	---	---	---	---	20.04
3.52	1.884	141.22	20.11	---	---	---	---	---	---	---	---	20.11
3.54	1.896	141.24	20.17	---	---	---	---	---	---	---	---	20.17
3.56	1.908	141.26	20.24	---	---	---	---	---	---	---	---	20.24
3.58	1.921	141.28	20.31	---	---	---	---	---	---	---	---	20.31
3.60	1.933	141.30	20.38	---	---	---	---	---	---	---	---	20.38
3.62	1.945	141.32	20.45	---	---	---	---	---	---	---	---	20.45
3.64	1.958	141.34	20.52	---	---	---	---	---	---	---	---	20.52
3.66	1.970	141.36	20.59	---	---	---	---	---	---	---	---	20.59
3.68	1.982	141.38	20.65	---	---	---	---	---	---	---	---	20.65
3.70	1.995	141.40	20.72	---	---	---	---	---	---	---	---	20.72
3.72	2.007	141.42	20.79	---	---	---	---	---	---	---	---	20.79
3.74	2.019	141.44	20.86	---	---	---	---	---	---	---	---	20.86
3.76	2.032	141.46	20.92	---	---	---	---	---	---	---	---	20.92
3.78	2.044	141.48	20.99	---	---	---	---	---	---	---	---	20.99
3.80	2.057	141.50	21.05	---	---	---	---	---	---	---	---	21.05
3.82	2.069	141.52	21.12	---	---	---	---	---	---	---	---	21.12
3.84	2.082	141.54	21.19	---	---	---	---	---	---	---	---	21.19
3.86	2.094	141.56	21.25	---	---	---	---	---	---	---	---	21.25
3.88	2.107	141.58	21.32	---	---	---	---	---	---	---	---	21.32
3.90	2.119	141.60	21.38	---	---	---	---	---	---	---	---	21.38
3.92	2.132	141.62	21.45	---	---	---	---	---	---	---	---	21.45
3.94	2.145	141.64	21.51	---	---	---	---	---	---	---	---	21.51
3.96	2.157	141.66	21.58	---	---	---	---	---	---	---	---	21.58
3.98	2.170	141.68	21.64	---	---	---	---	---	---	---	---	21.64
4.00	2.182	141.70	21.71	---	---	---	---	---	---	---	---	21.71

...End

Appendix E
Lot Grading Plan

NW Cor., NW 1/4, Sec. 25, T27S, R2W, 6th P.M.

NE Cor., NW 1/4, Sec. 25, T27S, R2W, 6th P.M.

135TH ST. W.

MAPLE ST.

LIMUEL CT. 8

AUBURN HILLS COMMERCIAL ADDITION
VACANT LOT

POND
TO BE RELOCATED
TO RESERVE "A"

10

A

18
VO=45.1

AUBURN HILLS SRD ADDITION
ZONED SF-5'

PROF. OVERFLOW CHANNEL
WIDTH=5.0 ft.
SIDE SLOPE= 3:1
SLOPE=0.25%

19
VO=45.5

20
VO=46.0

21
VO=46.2

22
VO=46.8

23
VO=48.2

24

LIMUEL CT.

AUBURN HILLS 7TH ADDITION

RESERVE "A"

PROPOSED POOL
Storage=2.1 acre-ft.
Surface Area=0.64 acres
NP=139.5
100-YR.=142.3

LEGEND

- BT - CONIFEROUS TREE & DIAMETER
- DN - DECIDUOUS TREE & DIAMETER
- SN - SIGN
- B - BUSH
- ET - EDGE OF TREES
- F - FENCE
- SSMH - SANITARY SEWER MANHOLE
- GM - GAS METER
- P - POLE
- HLP - HIGH LINE POLE
- G - GATE
- LP - LIGHT POLE
- FH - FIRE HYDRANT
- WV - WATER VALVE
- WM - WATER METER
- PP - POWER POLE AND GUY ANCHOR
- TR - TELEPHONE RISER
- I - INLET
- SS - STORM SEWER PIPE
- W - WATER LINE
- SSS - SANITARY SEWER LINE
- G - GAS LINE
- UT - UNDERGROUND TELEPHONE LINE
- OE - OVERHEAD TELEPHONE
- OE - OVERHEAD ELECTRIC
- UF - UNDERGROUND FIBER OPTIC CABLE
- SC - SECTION CORNER
- PCF - PROPERTY CORNER FOUND
- BM - BENCHMARK
- E - ELEVATIONS
- 7.71 - EXISTING CONTOURS
- 141.5 - PROPOSED CONTOURS

BENCH MARK

BM " " Cut on East Side of Light Pole Base
Elev. = 147.63 City Datum

MINIMUM PAD ELEVATIONS (LOWEST OPENINGS)		ELEVATION	
LOTS	BLOCK	(CITY DATUM)	(NGVD)
1	1	145.2	1332.6

NOTES

- ZONING: Existing - NR & SF-5 & P.O.-130
Proposed - ALL NR & P.O.-130 as per the terms and provisions contained in the document entitled "Notice of Protective Overlay" recorded as Doc/Fm-Pg: 28591454 of official records.
- EXISTING USE: Vacant Land
- PLAT AREA: 4.64 AC
- SURVEY DATE: May 10th, 2005 (Baughman, Co., P.A.)
- MINIMUM PADS: As shown on the Final Drainage Plan
- LOT TOTAL: 1
- RESERVE "A": Drainage, opens pace, landscaping, irrigation.
- Per FEMA FIRM 200321 0200 A, effective date of June 3rd, 1986, subject property lies w/in Zone C.

PLAT LOCATION

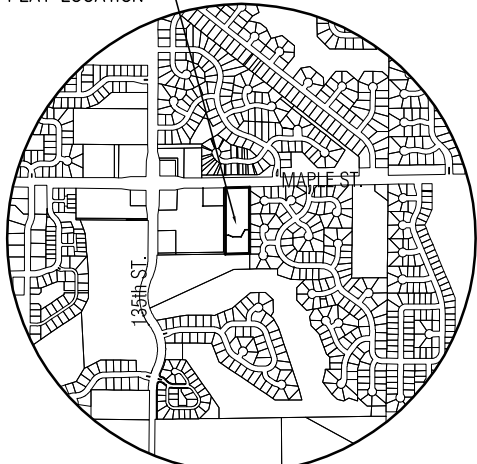

VICINITY MAP

LOT GRADING PLAN

AUBURN HILLS COMMERCIAL 4th ADDITION

OWNER / DEVELOPER: Occidental Management, Inc.

300 N. Main St.

Wichita, KS 67202

Date: August 8th, 2005



MKEC
ENGINEERING
CONSULTANTS
411 N. WEBB ROAD
WICHITA, KS. 67204
316-694-9000

8/1/2005 10:27:30 AM CDT C:\m\05\03\Drainage\05403DU.dwg

Appendix F
Drainage and Utility Plan

NW Cor., NW 1/4, Sec. 25,
T27S, R2W, 6th P.M.

NE Cor., NW 1/4, Sec. 25,
T27S, R2W, 6th P.M.

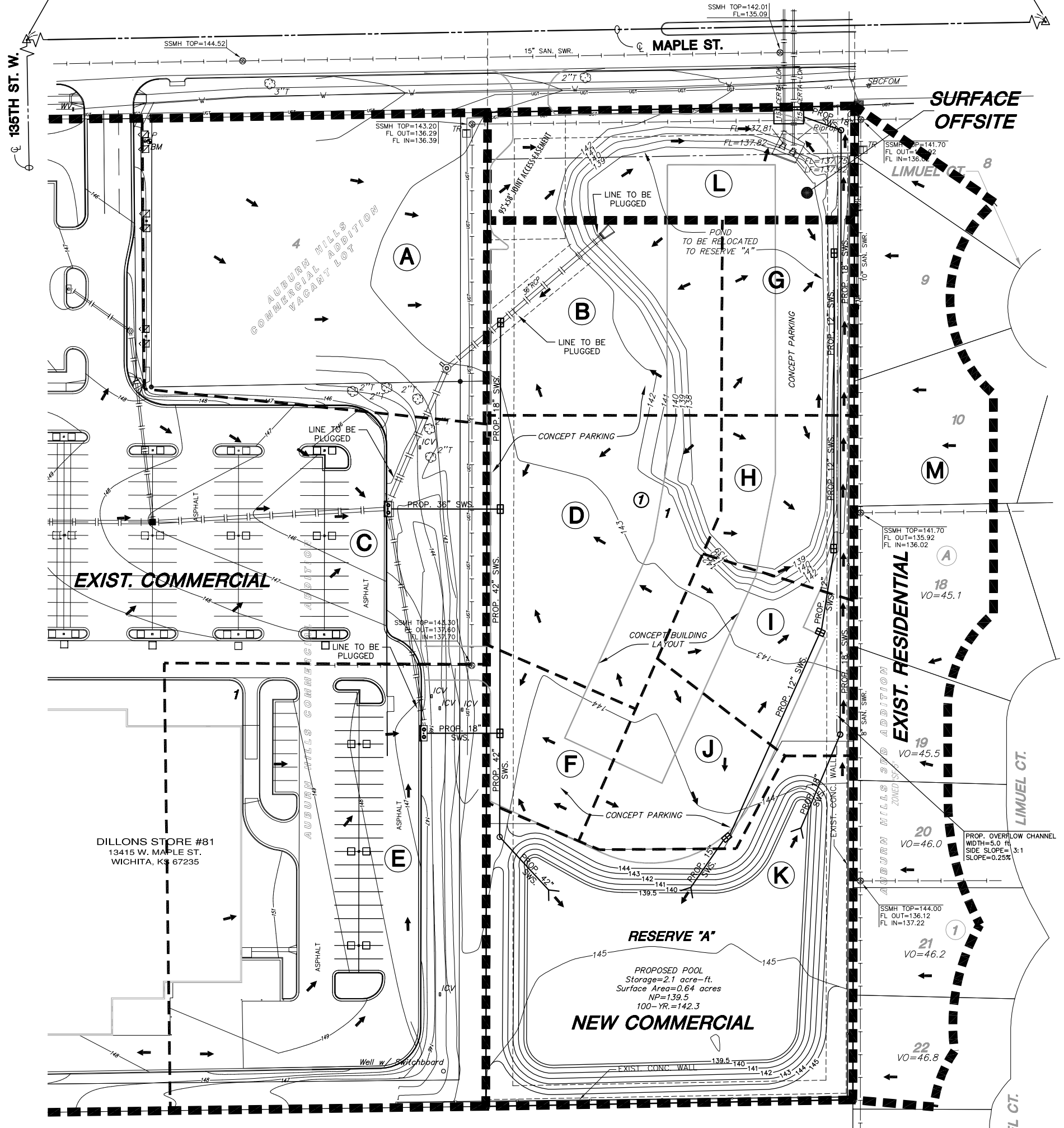

STAGE	ELEV.	STORAGE (acre-ft.)	DISCHARGE (cfs)
0.0	139.5	0.0	0.0
1.0	140.0	0.3	1.3
2.0	141.0	1.0	7.4
3.0	142.0	1.8	11.3
4.0	143.0	2.7	14.1

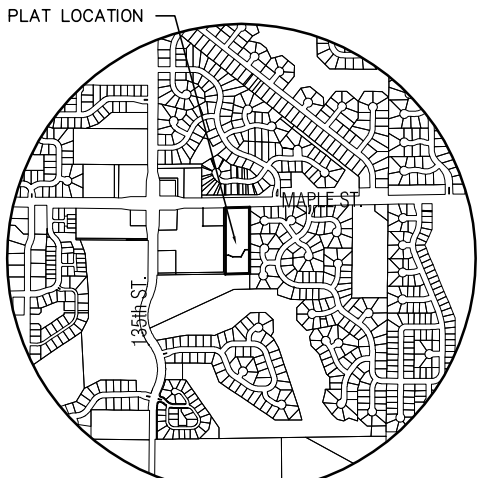

VICINITY MAP

LEGEND

- BIN - CONIFEROUS TREE & DIAMETER
- DN - DECIDUOUS TREE & DIAMETER
- SN - SIGN
- BUSH
- EDGE OF TREES
- - - FENCE
- SSMH - SANITARY SEWER MANHOLE
- GM - GAS METER
- POLE - POLE
- HLP - HIGH LINE POLE
- GATE
- WALL
- LP - LIGHT POLE
- TH - FIRE HYDRANT
- WV - WATER VALVE
- WM - WATER METER
- AW - SUB-WATER DRNG. LABELS
- FLOW ARROW
- PR - POWER POLE AND GUY ANCHOR
- TR - TELEPHONE RISER
- INLET
- STORM SEWER PIPE
- WATER LINE
- SANITARY SEWER LINE
- GAS LINE
- TELEPHONE LINE
- UNDERGROUND ELECTRIC LINE
- OVERHEAD TELEPHONE
- OVERHEAD ELECTRIC
- UNDERGROUND FIBER OPTIC CABLE
- SECTION CORNER
- PROPERTY CORNER FOUND
- BM - BENCHMARK
- HYDRFLOW BOUNDARIES
- INLET DRNG. AREAS
- EXISTING CONTOURS
- PROPOSED CONTOURS

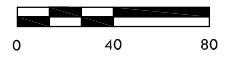

BENCH MARK

BM " " Cut on East Side of Light Pole Base
Elev. = 147.63 City Datum

DRAINAGE AND UTILITY PLAN

AUBURN HILLS COMMERCIAL 4th ADDITION

OWNER / DEVELOPER: Occidental Management, Inc.

300 N. Main St.

Wichita, KS 67202

Date: August 8th, 2005



8/1/2005 10:27:30 AM CDT C:\M\054031.dwg Drainage\054030U.dwg

Appendix G

Flowmaster Output

Cross Section
Cross Section for Trapezoidal Channel

Project Description	
Project File	k:\wp\project\2005\05403 - auburn hills commercial 4th add\drng\emergenc.fm2
Worksheet	Emergency Ditch
Flow Element	Trapezoidal Channel
Method	Manning's Formula
Solve For	Channel Depth

Section Data	
Mannings Coefficient	0.030
Channel Slope	0.002500 ft/ft
Depth	1.24 ft
Left Side Slope	3.000000 H : V
Right Side Slope	3.000000 H : V
Bottom Width	5.00 ft
Discharge	24.00 cfs

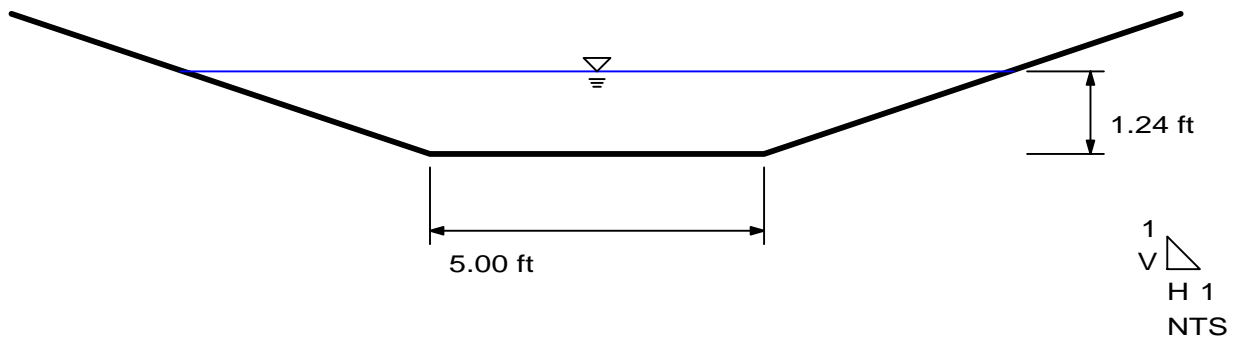

Conc. Emergency Ditch
Worksheet for Trapezoidal Channel

Project Description	
Project File	k:\wp\project\2005\05403 - auburn hills commercial 4th add\drng\emergenc.fm2
Worksheet	Emergency Ditch
Flow Element	Trapezoidal Channel
Method	Manning's Formula
Solve For	Channel Depth

Input Data	
Mannings Coefficient	0.030
Channel Slope	0.002500 ft/ft
Left Side Slope	3.000000 H : V
Right Side Slope	3.000000 H : V
Bottom Width	5.00 ft
Discharge	24.00 cfs

Results	
Depth	1.24 ft
Flow Area	10.85 ft ²
Wetted Perimeter	12.86 ft
Top Width	12.46 ft
Critical Depth	0.76 ft
Critical Slope	0.016268 ft/ft
Velocity	2.21 ft/s
Velocity Head	0.08 ft
Specific Energy	1.32 ft
Froude Number	0.42
Flow is subcritical.	

Appendix H
Proposed Hydraflow Hydrographs
By Intelisolve
Output

Hydrograph Return Period Recap

Hyd. No.	Hydrograph type (origin)	Inflow Hyd(s)	Peak Outflow (cfs)								Hydrograph description
			1-Yr	2-Yr	3-Yr	5-Yr	10-Yr	25-Yr	50-Yr	100-Yr	
1	Rational	-----	-----	14.43	-----	17.06	19.57	-----	-----	27.61	New Commercial
2	Rational	-----	-----	44.44	-----	52.53	60.29	-----	-----	85.05	Existing Commercial
3	Combine	1, 2	-----	58.87	-----	69.59	79.86	-----	-----	112.66	Flow Into Pond
4	Reservoir	3	-----	7.55	-----	8.65	9.59	-----	-----	12.08	Prop. Pond
5	Rational	-----	-----	1.82	-----	2.15	2.47	-----	-----	3.49	Surface offsite
6	Combine	4, 5	-----	8.00	-----	9.21	10.26	-----	-----	13.18	Into 2-15inch SWS
7	Rational	-----	-----	3.38	-----	3.99	4.58	-----	-----	6.46	Res Offsite
8	Combine	6, 7	-----	9.73	-----	11.57	13.14	-----	-----	17.86	Total Offsite

Proj. file: Post 9-05.gpw

Run date: 09-23-2005

Hydrograph Summary Report

Hyd. No.	Hydrograph type (origin)	Peak flow (cfs)	Time interval (min)	Time to peak (min)	Volume (acft)	Inflow hyd(s)	Maximum elevation (ft)	Maximum storage (acft)	Hydrograph description	
1	Rational	14.43	1	15	0.298	---	----	----	New Commercial	
2	Rational	44.44	1	15	0.918	---	----	----	Existing Commercial	
3	Combine	58.87	1	15	1.216	1, 2	----	----	Flow Into Pond	
4	Reservoir	7.55	1	28	1.182	3	141.04	1.076	Prop. Pond	
5	Rational	1.82	1	15	0.038	---	----	----	Surface offsite	
6	Combine	8.00	1	24	1.219	4, 5	----	----	Into 2-15inch SWS	
7	Rational	3.38	1	15	0.070	---	----	----	Res Offsite	
8	Combine	9.73	1	21	1.289	6, 7	----	----	Total Offsite	
Proj. file: Post 9-05.gpw				Return Period: 2 yr				Run date: 09-23-2005		

Hydrograph Summary Report

Hyd. No.	Hydrograph type (origin)	Peak flow (cfs)	Time interval (min)	Time to peak (min)	Volume (acft)	Inflow hyd(s)	Maximum elevation (ft)	Maximum storage (acft)	Hydrograph description	
1	Rational	17.06	1	15	0.352	---	----	----	New Commercial	
2	Rational	52.53	1	15	1.085	---	----	----	Existing Commercial	
3	Combine	69.59	1	15	1.438	1, 2	----	----	Flow Into Pond	
4	Reservoir	8.65	1	28	1.402	3	141.28	1.270	Prop. Pond	
5	Rational	2.15	1	15	0.044	---	----	----	Surface offsite	
6	Combine	9.21	1	24	1.447	4, 5	----	----	Into 2-15inch SWS	
7	Rational	3.99	1	15	0.082	---	----	----	Res Offsite	
8	Combine	11.57	1	19	1.529	6, 7	----	----	Total Offsite	
Proj. file: Post 9-05.gpw				Return Period: 5 yr				Run date: 09-23-2005		

Hydrograph Summary Report

Hyd. No.	Hydrograph type (origin)	Peak flow (cfs)	Time interval (min)	Time to peak (min)	Volume (acft)	Inflow hyd(s)	Maximum elevation (ft)	Maximum storage (acft)	Hydrograph description	
1	Rational	19.57	1	15	0.404	---	----	----	New Commercial	
2	Rational	60.29	1	15	1.246	---	----	----	Existing Commercial	
3	Combine	79.86	1	15	1.650	1, 2	----	----	Flow Into Pond	
4	Reservoir	9.59	1	28	1.614	3	141.52	1.459	Prop. Pond	
5	Rational	2.47	1	15	0.051	---	----	----	Surface offsite	
6	Combine	10.26	1	24	1.665	4, 5	----	----	Into 2-15inch SWS	
7	Rational	4.58	1	15	0.095	---	----	----	Res Offsite	
8	Combine	13.14	1	18	1.760	6, 7	----	----	Total Offsite	
Proj. file: Post 9-05.gpw				Return Period: 10 yr				Run date: 09-23-2005		

Hydrograph Summary Report

Hyd. No.	Hydrograph type (origin)	Peak flow (cfs)	Time interval (min)	Time to peak (min)	Volume (acft)	Inflow hyd(s)	Maximum elevation (ft)	Maximum storage (acft)	Hydrograph description	
1	Rational	27.61	1	15	0.571	---	----	----	New Commercial	
2	Rational	85.05	1	15	1.757	---	----	----	Existing Commercial	
3	Combine	112.66	1	15	2.328	1, 2	----	----	Flow Into Pond	
4	Reservoir	12.08	1	28	2.291	3	142.27	2.069	Prop. Pond	
5	Rational	3.49	1	15	0.072	---	----	----	Surface offsite	
6	Combine	13.18	1	22	2.363	4, 5	----	----	Into 2-15inch SWS	
7	Rational	6.46	1	15	0.134	---	----	----	Res Offsite	
8	Combine	17.86	1	16	2.496	6, 7	----	----	Total Offsite	
Proj. file: Post 9-05.gpw				Return Period: 100 yr			Run date: 09-23-2005			

Hydrograph Report

Hyd. No. 1

New Commercial

Hydrograph type	= Rational	Peak discharge	= 27.61 cfs
Storm frequency	= 100 yrs	Time interval	= 1 min
Drainage area	= 4.1 ac	Runoff coeff.	= 0.91
Intensity	= 7.365 in/hr	Time of conc. (Tc)	= 15 min
IDF Curve	= SedgwickCoKS.IDF	Asc/Rec limb fact	= 1/1

Hydrograph Volume = 0.571 acft

Hydrograph Discharge Table

Time -- Outflow
(hrs cfs)

0.07	7.36
0.08	9.20
0.10	11.05
0.12	12.89
0.13	14.73
0.15	16.57
0.17	18.41
0.18	20.25
0.20	22.09
0.22	23.93
0.23	25.77
0.25	27.61 <<
0.27	25.77
0.28	23.93
0.30	22.09
0.32	20.25
0.33	18.41
0.35	16.57
0.37	14.73
0.38	12.89
0.40	11.05
0.42	9.20
0.43	7.36
0.45	5.52

...End

Hydrograph Report

Hyd. No. 2

Existing Commercial

Hydrograph type	= Rational	Peak discharge	= 85.05 cfs
Storm frequency	= 100 yrs	Time interval	= 1 min
Drainage area	= 12.7 ac	Runoff coeff.	= 0.91
Intensity	= 7.365 in/hr	Time of conc. (Tc)	= 15 min
IDF Curve	= SedgwickCoKS.IDF	Asc/Rec limb fact	= 1/1

Hydrograph Volume = 1.757 acft

Hydrograph Discharge Table

Time -- Outflow
(hrs cfs)

0.05	17.01
0.07	22.68
0.08	28.35
0.10	34.02
0.12	39.69
0.13	45.36
0.15	51.03
0.17	56.70
0.18	62.37
0.20	68.04
0.22	73.71
0.23	79.38
0.25	85.05 <<
0.27	79.38
0.28	73.71
0.30	68.04
0.32	62.37
0.33	56.70
0.35	51.03
0.37	45.36
0.38	39.69
0.40	34.02
0.42	28.35
0.43	22.68

...End

Hydrograph Report

Hyd. No. 3

Flow Into Pond

Hydrograph type = Combine
Storm frequency = 100 yrs
Inflow hyds. = 1, 2

Peak discharge = 112.66 cfs
Time interval = 1 min

Hydrograph Volume = 2.328 acft

Hydrograph Discharge Table

Time (hrs)	Hyd. 1 + (cfs)	Hyd. 2 = (cfs)	Outflow (cfs)
0.07	7.36	22.68	30.04
0.08	9.20	28.35	37.55
0.10	11.05	34.02	45.07
0.12	12.89	39.69	52.58
0.13	14.73	45.36	60.09
0.15	16.57	51.03	67.60
0.17	18.41	56.70	75.11
0.18	20.25	62.37	82.62
0.20	22.09	68.04	90.13
0.22	23.93	73.71	97.64
0.23	25.77	79.38	105.15
0.25	27.61 <<	85.05 <<	112.66 <<
0.27	25.77	79.38	105.15
0.28	23.93	73.71	97.64
0.30	22.09	68.04	90.13
0.32	20.25	62.37	82.62
0.33	18.41	56.70	75.11
0.35	16.57	51.03	67.60
0.37	14.73	45.36	60.09
0.38	12.89	39.69	52.58
0.40	11.05	34.02	45.07
0.42	9.20	28.35	37.55
0.43	7.36	22.68	30.04

...End

Hydrograph Report

Hyd. No. 4

Prop. Pond

Hydrograph type = Reservoir
 Storm frequency = 100 yrs
 Inflow hyd. No. = 3
 Max. Elevation = 142.27 ft

Peak discharge = 12.08 cfs
 Time interval = 1 min
 Reservoir name = Proposed Pond
 Max. Storage = 2.069 acft

Storage Indication method used.

Outflow hydrograph volume = 2.291 acft

Hydrograph Discharge Table

Time (hrs)	Inflow cfs	Elevation ft	Clv A cfs	Clv B cfs	Clv C cfs	Clv D cfs	Wr A cfs	Wr B cfs	Wr C cfs	Wr D cfs	Exfil cfs	Outflow cfs
0.17	75.11	140.25	2.67	----	----	----	----	----	----	----	----	2.67
0.18	82.62	140.40	3.66	----	----	----	----	----	----	----	----	3.66
0.20	90.13	140.55	4.70	----	----	----	----	----	----	----	----	4.70
0.22	97.64	140.72	5.86	----	----	----	----	----	----	----	----	5.86
0.23	105.15	140.91	6.96	----	----	----	----	----	----	----	----	6.96
0.25	112.66 <<	141.09	7.81	----	----	----	----	----	----	----	----	7.81
0.27	105.15	141.27	8.58	----	----	----	----	----	----	----	----	8.58
0.28	97.64	141.43	9.23	----	----	----	----	----	----	----	----	9.23
0.30	90.13	141.58	9.79	----	----	----	----	----	----	----	----	9.79
0.32	82.62	141.71	10.27	----	----	----	----	----	----	----	----	10.27
0.33	75.11	141.83	10.68	----	----	----	----	----	----	----	----	10.68
0.35	67.60	141.93	11.04	----	----	----	----	----	----	----	----	11.04
0.37	60.09	142.02	11.33	----	----	----	----	----	----	----	----	11.33
0.38	52.58	142.09	11.55	----	----	----	----	----	----	----	----	11.55
0.40	45.07	142.15	11.73	----	----	----	----	----	----	----	----	11.73
0.42	37.55	142.20	11.88	----	----	----	----	----	----	----	----	11.88
0.43	30.04	142.23	11.98	----	----	----	----	----	----	----	----	11.98
0.45	22.53	142.26	12.05	----	----	----	----	----	----	----	----	12.05
0.47	15.02	142.27 <<	12.08	----	----	----	----	----	----	----	----	12.08 <<
0.48	7.51	142.27	12.08	----	----	----	----	----	----	----	----	12.08
0.50	0.00	142.25	12.04	----	----	----	----	----	----	----	----	12.04
0.52	0.00	142.23	11.98	----	----	----	----	----	----	----	----	11.98
0.53	0.00	142.21	11.93	----	----	----	----	----	----	----	----	11.93
0.55	0.00	142.20	11.87	----	----	----	----	----	----	----	----	11.87
0.57	0.00	142.18	11.81	----	----	----	----	----	----	----	----	11.81
0.58	0.00	142.16	11.75	----	----	----	----	----	----	----	----	11.75
0.60	0.00	142.14	11.69	----	----	----	----	----	----	----	----	11.69
0.62	0.00	142.12	11.64	----	----	----	----	----	----	----	----	11.64
0.63	0.00	142.10	11.58	----	----	----	----	----	----	----	----	11.58
0.65	0.00	142.08	11.52	----	----	----	----	----	----	----	----	11.52
0.67	0.00	142.07	11.47	----	----	----	----	----	----	----	----	11.47
0.68	0.00	142.05	11.41	----	----	----	----	----	----	----	----	11.41
0.70	0.00	142.03	11.35	----	----	----	----	----	----	----	----	11.35
0.72	0.00	142.01	11.29	----	----	----	----	----	----	----	----	11.29
0.73	0.00	141.99	11.23	----	----	----	----	----	----	----	----	11.23
0.75	0.00	141.97	11.17	----	----	----	----	----	----	----	----	11.17
0.77	0.00	141.96	11.11	----	----	----	----	----	----	----	----	11.11
0.78	0.00	141.94	11.04	----	----	----	----	----	----	----	----	11.04

Continues on next page...

Hydrograph Discharge Table

Time (hrs)	Inflow cfs	Elevation ft	Clv A cfs	Clv B cfs	Clv C cfs	Clv D cfs	Wr A cfs	Wr B cfs	Wr C cfs	Wr D cfs	Exfil cfs	Outflow cfs
0.80	0.00	141.92	10.98	----	----	----	----	----	----	----	----	10.98
0.82	0.00	141.90	10.92	----	----	----	----	----	----	----	----	10.92
0.83	0.00	141.88	10.86	----	----	----	----	----	----	----	----	10.86
0.85	0.00	141.86	10.79	----	----	----	----	----	----	----	----	10.79
0.87	0.00	141.84	10.73	----	----	----	----	----	----	----	----	10.73
0.88	0.00	141.82	10.67	----	----	----	----	----	----	----	----	10.67
0.90	0.00	141.80	10.60	----	----	----	----	----	----	----	----	10.60
0.92	0.00	141.79	10.54	----	----	----	----	----	----	----	----	10.54
0.93	0.00	141.77	10.48	----	----	----	----	----	----	----	----	10.48
0.95	0.00	141.75	10.41	----	----	----	----	----	----	----	----	10.41
0.97	0.00	141.73	10.35	----	----	----	----	----	----	----	----	10.35
0.98	0.00	141.71	10.29	----	----	----	----	----	----	----	----	10.29
1.00	0.00	141.69	10.23	----	----	----	----	----	----	----	----	10.23
1.02	0.00	141.68	10.16	----	----	----	----	----	----	----	----	10.16
1.03	0.00	141.66	10.10	----	----	----	----	----	----	----	----	10.10
1.05	0.00	141.64	10.04	----	----	----	----	----	----	----	----	10.04
1.07	0.00	141.62	9.97	----	----	----	----	----	----	----	----	9.97
1.08	0.00	141.61	9.91	----	----	----	----	----	----	----	----	9.91
1.10	0.00	141.59	9.85	----	----	----	----	----	----	----	----	9.85
1.12	0.00	141.57	9.78	----	----	----	----	----	----	----	----	9.78
1.13	0.00	141.56	9.72	----	----	----	----	----	----	----	----	9.72
1.15	0.00	141.54	9.66	----	----	----	----	----	----	----	----	9.66
1.17	0.00	141.52	9.60	----	----	----	----	----	----	----	----	9.60
1.18	0.00	141.51	9.53	----	----	----	----	----	----	----	----	9.53
1.20	0.00	141.49	9.47	----	----	----	----	----	----	----	----	9.47
1.22	0.00	141.47	9.41	----	----	----	----	----	----	----	----	9.41
1.23	0.00	141.46	9.34	----	----	----	----	----	----	----	----	9.34
1.25	0.00	141.44	9.28	----	----	----	----	----	----	----	----	9.28
1.27	0.00	141.42	9.22	----	----	----	----	----	----	----	----	9.22
1.28	0.00	141.41	9.15	----	----	----	----	----	----	----	----	9.15
1.30	0.00	141.39	9.09	----	----	----	----	----	----	----	----	9.09
1.32	0.00	141.38	9.03	----	----	----	----	----	----	----	----	9.03
1.33	0.00	141.36	8.96	----	----	----	----	----	----	----	----	8.96
1.35	0.00	141.35	8.90	----	----	----	----	----	----	----	----	8.90
1.37	0.00	141.33	8.84	----	----	----	----	----	----	----	----	8.84
1.38	0.00	141.31	8.78	----	----	----	----	----	----	----	----	8.78
1.40	0.00	141.30	8.71	----	----	----	----	----	----	----	----	8.71
1.42	0.00	141.28	8.65	----	----	----	----	----	----	----	----	8.65
1.43	0.00	141.27	8.59	----	----	----	----	----	----	----	----	8.59
1.45	0.00	141.25	8.52	----	----	----	----	----	----	----	----	8.52
1.47	0.00	141.24	8.46	----	----	----	----	----	----	----	----	8.46
1.48	0.00	141.22	8.40	----	----	----	----	----	----	----	----	8.40
1.50	0.00	141.21	8.34	----	----	----	----	----	----	----	----	8.34
1.52	0.00	141.20	8.27	----	----	----	----	----	----	----	----	8.27
1.53	0.00	141.18	8.21	----	----	----	----	----	----	----	----	8.21
1.55	0.00	141.17	8.14	----	----	----	----	----	----	----	----	8.14
1.57	0.00	141.15	8.08	----	----	----	----	----	----	----	----	8.08
1.58	0.00	141.14	8.02	----	----	----	----	----	----	----	----	8.02
1.60	0.00	141.13	7.96	----	----	----	----	----	----	----	----	7.96
1.62	0.00	141.11	7.89	----	----	----	----	----	----	----	----	7.89
1.63	0.00	141.10	7.83	----	----	----	----	----	----	----	----	7.83

Continues on next page...

Hydrograph Discharge Table

Time (hrs)	Inflow cfs	Elevation ft	Clv A cfs	Clv B cfs	Clv C cfs	Clv D cfs	Wr A cfs	Wr B cfs	Wr C cfs	Wr D cfs	Exfil cfs	Outflow cfs
1.65	0.00	141.08	7.77	----	----	----	----	----	----	----	----	7.77
1.67	0.00	141.07	7.70	----	----	----	----	----	----	----	----	7.70
1.68	0.00	141.06	7.64	----	----	----	----	----	----	----	----	7.64
1.70	0.00	141.04	7.58	----	----	----	----	----	----	----	----	7.58
1.72	0.00	141.03	7.51	----	----	----	----	----	----	----	----	7.51
1.73	0.00	141.02	7.45	----	----	----	----	----	----	----	----	7.45
1.75	0.00	141.00	7.39	----	----	----	----	----	----	----	----	7.39
1.77	0.00	140.99	7.33	----	----	----	----	----	----	----	----	7.33
1.78	0.00	140.98	7.27	----	----	----	----	----	----	----	----	7.27
1.80	0.00	140.96	7.21	----	----	----	----	----	----	----	----	7.21
1.82	0.00	140.95	7.15	----	----	----	----	----	----	----	----	7.15
1.83	0.00	140.94	7.08	----	----	----	----	----	----	----	----	7.08
1.85	0.00	140.92	7.03	----	----	----	----	----	----	----	----	7.03
1.87	0.00	140.91	6.97	----	----	----	----	----	----	----	----	6.97
1.88	0.00	140.90	6.90	----	----	----	----	----	----	----	----	6.90
1.90	0.00	140.88	6.82	----	----	----	----	----	----	----	----	6.82
1.92	0.00	140.87	6.74	----	----	----	----	----	----	----	----	6.74
1.93	0.00	140.86	6.66	----	----	----	----	----	----	----	----	6.66
1.95	0.00	140.84	6.58	----	----	----	----	----	----	----	----	6.58
1.97	0.00	140.83	6.51	----	----	----	----	----	----	----	----	6.51
1.98	0.00	140.82	6.43	----	----	----	----	----	----	----	----	6.43
2.00	0.00	140.81	6.36	----	----	----	----	----	----	----	----	6.36
2.02	0.00	140.79	6.28	----	----	----	----	----	----	----	----	6.28
2.03	0.00	140.78	6.21	----	----	----	----	----	----	----	----	6.21
2.05	0.00	140.77	6.14	----	----	----	----	----	----	----	----	6.14
2.07	0.00	140.76	6.07	----	----	----	----	----	----	----	----	6.07
2.08	0.00	140.75	6.00	----	----	----	----	----	----	----	----	6.00
2.10	0.00	140.74	5.93	----	----	----	----	----	----	----	----	5.93
2.12	0.00	140.72	5.86	----	----	----	----	----	----	----	----	5.86
2.13	0.00	140.71	5.79	----	----	----	----	----	----	----	----	5.79
2.15	0.00	140.70	5.73	----	----	----	----	----	----	----	----	5.73
2.17	0.00	140.69	5.65	----	----	----	----	----	----	----	----	5.65
2.18	0.00	140.68	5.58	----	----	----	----	----	----	----	----	5.58
2.20	0.00	140.67	5.51	----	----	----	----	----	----	----	----	5.51
2.22	0.00	140.66	5.43	----	----	----	----	----	----	----	----	5.43
2.23	0.00	140.65	5.36	----	----	----	----	----	----	----	----	5.36
2.25	0.00	140.64	5.29	----	----	----	----	----	----	----	----	5.29
2.27	0.00	140.63	5.23	----	----	----	----	----	----	----	----	5.23
2.28	0.00	140.62	5.16	----	----	----	----	----	----	----	----	5.16
2.30	0.00	140.61	5.09	----	----	----	----	----	----	----	----	5.09
2.32	0.00	140.60	5.02	----	----	----	----	----	----	----	----	5.02
2.33	0.00	140.59	4.95	----	----	----	----	----	----	----	----	4.95
2.35	0.00	140.58	4.88	----	----	----	----	----	----	----	----	4.89
2.37	0.00	140.57	4.82	----	----	----	----	----	----	----	----	4.82
2.38	0.00	140.56	4.75	----	----	----	----	----	----	----	----	4.75
2.40	0.00	140.55	4.68	----	----	----	----	----	----	----	----	4.68
2.42	0.00	140.54	4.62	----	----	----	----	----	----	----	----	4.62
2.43	0.00	140.53	4.55	----	----	----	----	----	----	----	----	4.55
2.45	0.00	140.53	4.49	----	----	----	----	----	----	----	----	4.49
2.47	0.00	140.52	4.43	----	----	----	----	----	----	----	----	4.43
2.48	0.00	140.51	4.37	----	----	----	----	----	----	----	----	4.37

Continues on next page...

Hydrograph Discharge Table

Time (hrs)	Inflow cfs	Elevation ft	Clv A cfs	Clv B cfs	Clv C cfs	Clv D cfs	Wr A cfs	Wr B cfs	Wr C cfs	Wr D cfs	Exfil cfs	Outflow cfs
2.50	0.00	140.50	4.31	----	----	----	----	----	----	----	----	4.31
2.52	0.00	140.49	4.25	----	----	----	----	----	----	----	----	4.25
2.53	0.00	140.48	4.21	----	----	----	----	----	----	----	----	4.21
2.55	0.00	140.48	4.16	----	----	----	----	----	----	----	----	4.16
2.57	0.00	140.47	4.11	----	----	----	----	----	----	----	----	4.11
2.58	0.00	140.46	4.06	----	----	----	----	----	----	----	----	4.06
2.60	0.00	140.45	4.01	----	----	----	----	----	----	----	----	4.01
2.62	0.00	140.44	3.96	----	----	----	----	----	----	----	----	3.96
2.63	0.00	140.44	3.92	----	----	----	----	----	----	----	----	3.92
2.65	0.00	140.43	3.87	----	----	----	----	----	----	----	----	3.87
2.67	0.00	140.42	3.83	----	----	----	----	----	----	----	----	3.83
2.68	0.00	140.41	3.78	----	----	----	----	----	----	----	----	3.78
2.70	0.00	140.41	3.74	----	----	----	----	----	----	----	----	3.74
2.72	0.00	140.40	3.69	----	----	----	----	----	----	----	----	3.69
2.73	0.00	140.39	3.64	----	----	----	----	----	----	----	----	3.64
2.75	0.00	140.39	3.59	----	----	----	----	----	----	----	----	3.59
2.77	0.00	140.38	3.54	----	----	----	----	----	----	----	----	3.54
2.78	0.00	140.37	3.49	----	----	----	----	----	----	----	----	3.49
2.80	0.00	140.37	3.44	----	----	----	----	----	----	----	----	3.44
2.82	0.00	140.36	3.39	----	----	----	----	----	----	----	----	3.39
2.83	0.00	140.35	3.35	----	----	----	----	----	----	----	----	3.35
2.85	0.00	140.35	3.30	----	----	----	----	----	----	----	----	3.30
2.87	0.00	140.34	3.25	----	----	----	----	----	----	----	----	3.25
2.88	0.00	140.33	3.21	----	----	----	----	----	----	----	----	3.21
2.90	0.00	140.33	3.16	----	----	----	----	----	----	----	----	3.16
2.92	0.00	140.32	3.12	----	----	----	----	----	----	----	----	3.12
2.93	0.00	140.32	3.07	----	----	----	----	----	----	----	----	3.07
2.95	0.00	140.31	3.03	----	----	----	----	----	----	----	----	3.03
2.97	0.00	140.30	2.99	----	----	----	----	----	----	----	----	2.99
2.98	0.00	140.30	2.95	----	----	----	----	----	----	----	----	2.95
3.00	0.00	140.29	2.92	----	----	----	----	----	----	----	----	2.92
3.02	0.00	140.29	2.88	----	----	----	----	----	----	----	----	2.88
3.03	0.00	140.28	2.85	----	----	----	----	----	----	----	----	2.85
3.05	0.00	140.28	2.82	----	----	----	----	----	----	----	----	2.82
3.07	0.00	140.27	2.79	----	----	----	----	----	----	----	----	2.79
3.08	0.00	140.27	2.76	----	----	----	----	----	----	----	----	2.76
3.10	0.00	140.26	2.73	----	----	----	----	----	----	----	----	2.73
3.12	0.00	140.25	2.70	----	----	----	----	----	----	----	----	2.70
3.13	0.00	140.25	2.67	----	----	----	----	----	----	----	----	2.67
3.15	0.00	140.24	2.64	----	----	----	----	----	----	----	----	2.64
3.17	0.00	140.24	2.61	----	----	----	----	----	----	----	----	2.61
3.18	0.00	140.23	2.59	----	----	----	----	----	----	----	----	2.59
3.20	0.00	140.23	2.56	----	----	----	----	----	----	----	----	2.56
3.22	0.00	140.22	2.53	----	----	----	----	----	----	----	----	2.53
3.23	0.00	140.22	2.50	----	----	----	----	----	----	----	----	2.50
3.25	0.00	140.21	2.48	----	----	----	----	----	----	----	----	2.48
3.27	0.00	140.21	2.45	----	----	----	----	----	----	----	----	2.45
3.28	0.00	140.21	2.42	----	----	----	----	----	----	----	----	2.42

...End

Reservoir Report

Reservoir No. 2 - Proposed Pond

Hydraflow Hydrographs by Intelisolve

Pond Data

Pond storage is based on known contour areas. Average end area method used.

Stage / Storage Table

Stage (ft)	Elevation (ft)	Contour area (sqft)	Incr. Storage (acft)	Total storage (acft)
0.00	139.50	28,000	0.000	0.000
0.50	140.00	29,570	0.330	0.330
1.50	141.00	32,800	0.716	1.046
2.50	142.00	36,110	0.791	1.837
3.50	143.00	39,530	0.868	2.706

Culvert / Orifice Structures

	[A]	[B]	[C]	[D]
Rise in	= 18.0	0.0	0.0	0.0
Span in	= 18.0	0.0	0.0	0.0
No. Barrels	= 1	0	0	0
Invert El. ft	= 139.50	0.00	0.00	0.00
Length ft	= 0.0	0.0	0.0	0.0
Slope %	= 0.00	0.00	0.00	0.00
N-Value	= .013	.000	.000	.000
Orif. Coeff.	= 0.60	0.00	0.00	0.00
Multi-Stage	= n/a	No	No	No

Weir Structures

	[A]	[B]	[C]	[D]
Crest Len ft	= 0.00	0.00	0.00	0.00
Crest El. ft	= 0.00	0.00	0.00	0.00
Weir Coeff.	= 0.00	0.00	0.00	0.00
Weir Type	= ---	---	---	---
Multi-Stage	= No	No	No	No

Exfiltration Rate = 0.00 in/hr/sqft Tailwater Elev. = 0.00 ft

Note: All outflows have been analyzed under inlet and outlet control.

Stage / Storage / Discharge Table

Stage ft	Storage acft	Elevation ft	Clv A cfs	Clv B cfs	Clv C cfs	Clv D cfs	Wr A cfs	Wr B cfs	Wr C cfs	Wr D cfs	Exfil cfs	Total cfs
0.00	0.000	139.50	0.00	---	---	---	---	---	---	---	---	0.00
0.05	0.033	139.55	0.02	---	---	---	---	---	---	---	---	0.02
0.10	0.066	139.60	0.06	---	---	---	---	---	---	---	---	0.06
0.15	0.099	139.65	0.13	---	---	---	---	---	---	---	---	0.13
0.20	0.132	139.70	0.24	---	---	---	---	---	---	---	---	0.24
0.25	0.165	139.75	0.35	---	---	---	---	---	---	---	---	0.35
0.30	0.198	139.80	0.49	---	---	---	---	---	---	---	---	0.49
0.35	0.231	139.85	0.65	---	---	---	---	---	---	---	---	0.65
0.40	0.264	139.90	0.84	---	---	---	---	---	---	---	---	0.84
0.45	0.297	139.95	1.06	---	---	---	---	---	---	---	---	1.06
0.50	0.330	140.00	1.30	---	---	---	---	---	---	---	---	1.30
0.60	0.402	140.10	1.76	---	---	---	---	---	---	---	---	1.76
0.70	0.474	140.20	2.39	---	---	---	---	---	---	---	---	2.39
0.80	0.545	140.30	2.96	---	---	---	---	---	---	---	---	2.96
0.90	0.617	140.40	3.69	---	---	---	---	---	---	---	---	3.69
1.00	0.688	140.50	4.31	---	---	---	---	---	---	---	---	4.31
1.10	0.760	140.60	5.04	---	---	---	---	---	---	---	---	5.04
1.20	0.832	140.70	5.72	---	---	---	---	---	---	---	---	5.72
1.30	0.903	140.80	6.32	---	---	---	---	---	---	---	---	6.32
1.40	0.975	140.90	6.93	---	---	---	---	---	---	---	---	6.93
1.50	1.046	141.00	7.37	---	---	---	---	---	---	---	---	7.37
1.60	1.125	141.10	7.84	---	---	---	---	---	---	---	---	7.84
1.70	1.205	141.20	8.29	---	---	---	---	---	---	---	---	8.29
1.80	1.284	141.30	8.72	---	---	---	---	---	---	---	---	8.72
1.90	1.363	141.40	9.12	---	---	---	---	---	---	---	---	9.12
2.00	1.442	141.50	9.51	---	---	---	---	---	---	---	---	9.51
2.10	1.521	141.60	9.89	---	---	---	---	---	---	---	---	9.89
2.20	1.600	141.70	10.24	---	---	---	---	---	---	---	---	10.24
2.30	1.679	141.80	10.59	---	---	---	---	---	---	---	---	10.59
2.40	1.758	141.90	10.93	---	---	---	---	---	---	---	---	10.93
2.50	1.837	142.00	11.25	---	---	---	---	---	---	---	---	11.25
2.60	1.924	142.10	11.57	---	---	---	---	---	---	---	---	11.57
2.70	2.011	142.20	11.88	---	---	---	---	---	---	---	---	11.88

Continues on next page...

Stage / Storage / Discharge Table

Stage ft	Storage acft	Elevation ft	Clv A cfs	Clv B cfs	Clv C cfs	Clv D cfs	Wr A cfs	Wr B cfs	Wr C cfs	Wr D cfs	Exfil cfs	Total cfs
2.80	2.098	142.30	12.18	---	---	---	---	---	---	---	---	12.18
2.90	2.185	142.40	12.47	---	---	---	---	---	---	---	---	12.47
3.00	2.271	142.50	12.76	---	---	---	---	---	---	---	---	12.76
3.10	2.358	142.60	13.04	---	---	---	---	---	---	---	---	13.04
3.20	2.445	142.70	13.32	---	---	---	---	---	---	---	---	13.32
3.30	2.532	142.80	13.59	---	---	---	---	---	---	---	---	13.59
3.40	2.619	142.90	13.85	---	---	---	---	---	---	---	---	13.85
3.50	2.706	143.00	14.11	---	---	---	---	---	---	---	---	14.11

...End

Hydrograph Report

Hyd. No. 5

Surface offsite

Hydrograph type	= Rational	Peak discharge	= 3.49 cfs
Storm frequency	= 100 yrs	Time interval	= 1 min
Drainage area	= 0.5 ac	Runoff coeff.	= 0.91
Intensity	= 7.365 in/hr	Time of conc. (Tc)	= 15 min
IDF Curve	= SedgwickCoKS.IDF	Asc/Rec limb fact	= 1/1

Hydrograph Volume = 0.072 acft

Hydrograph Discharge Table

Time -- Outflow
(hrs cfs)

0.05	0.70
0.07	0.93
0.08	1.16
0.10	1.39
0.12	1.63
0.13	1.86
0.15	2.09
0.17	2.32
0.18	2.56
0.20	2.79
0.22	3.02
0.23	3.25
0.25	3.49 <<
0.27	3.25
0.28	3.02
0.30	2.79
0.32	2.56
0.33	2.32
0.35	2.09
0.37	1.86
0.38	1.63
0.40	1.39
0.42	1.16
0.43	0.93

...End

Hydrograph Report

Hyd. No. 6

Into 2-15inch SWS

Hydrograph type = Combine
Storm frequency = 100 yrs
Inflow hyds. = 4, 5

Peak discharge = 13.18 cfs
Time interval = 1 min

Hydrograph Volume = 2.363 acft

Hydrograph Discharge Table

Time (hrs)	Hyd. 4 + (cfs)	Hyd. 5 = (cfs)	Outflow (cfs)
0.13	1.29	1.86	3.14
0.15	1.86	2.09	3.95
0.17	2.67	2.32	4.99
0.18	3.66	2.56	6.21
0.20	4.70	2.79	7.48
0.22	5.86	3.02	8.88
0.23	6.96	3.25	10.21
0.25	7.81	3.49 <<	11.29
0.27	8.58	3.25	11.83
0.28	9.23	3.02	12.25
0.30	9.79	2.79	12.58
0.32	10.27	2.56	12.83
0.33	10.68	2.32	13.01
0.35	11.04	2.09	13.13
0.37	11.33	1.86	13.18 <<
0.38	11.55	1.63	13.18
0.40	11.73	1.39	13.13
0.42	11.88	1.16	13.04
0.43	11.98	0.93	12.91
0.45	12.05	0.70	12.75
0.47	12.08 <<	0.46	12.55
0.48	12.08	0.23	12.31
0.50	12.04	0.00	12.04
0.52	11.98	0.00	11.98
0.53	11.93	0.00	11.93
0.55	11.87	0.00	11.87
0.57	11.81	0.00	11.81
0.58	11.75	0.00	11.75
0.60	11.69	0.00	11.69
0.62	11.64	0.00	11.64
0.63	11.58	0.00	11.58
0.65	11.52	0.00	11.52
0.67	11.47	0.00	11.47
0.68	11.41	0.00	11.41
0.70	11.35	0.00	11.35
0.72	11.29	0.00	11.29
0.73	11.23	0.00	11.23
0.75	11.17	0.00	11.17

Continues on next page...

Hydrograph Discharge Table

Time (hrs)	Hyd. 4 + (cfs)	Hyd. 5 = (cfs)	Outflow (cfs)
0.77	11.11	0.00	11.11
0.78	11.04	0.00	11.04
0.80	10.98	0.00	10.98
0.82	10.92	0.00	10.92
0.83	10.86	0.00	10.86
0.85	10.79	0.00	10.79
0.87	10.73	0.00	10.73
0.88	10.67	0.00	10.67
0.90	10.60	0.00	10.60
0.92	10.54	0.00	10.54
0.93	10.48	0.00	10.48
0.95	10.41	0.00	10.41
0.97	10.35	0.00	10.35
0.98	10.29	0.00	10.29
1.00	10.23	0.00	10.23
1.02	10.16	0.00	10.16
1.03	10.10	0.00	10.10
1.05	10.04	0.00	10.04
1.07	9.97	0.00	9.97
1.08	9.91	0.00	9.91
1.10	9.85	0.00	9.85
1.12	9.78	0.00	9.78
1.13	9.72	0.00	9.72
1.15	9.66	0.00	9.66
1.17	9.60	0.00	9.60
1.18	9.53	0.00	9.53
1.20	9.47	0.00	9.47
1.22	9.41	0.00	9.41
1.23	9.34	0.00	9.34
1.25	9.28	0.00	9.28
1.27	9.22	0.00	9.22
1.28	9.15	0.00	9.15
1.30	9.09	0.00	9.09
1.32	9.03	0.00	9.03
1.33	8.96	0.00	8.96
1.35	8.90	0.00	8.90
1.37	8.84	0.00	8.84
1.38	8.78	0.00	8.78
1.40	8.71	0.00	8.71
1.42	8.65	0.00	8.65
1.43	8.59	0.00	8.59
1.45	8.52	0.00	8.52
1.47	8.46	0.00	8.46
1.48	8.40	0.00	8.40
1.50	8.34	0.00	8.34
1.52	8.27	0.00	8.27
1.53	8.21	0.00	8.21
1.55	8.14	0.00	8.14
1.57	8.08	0.00	8.08
1.58	8.02	0.00	8.02
1.60	7.96	0.00	7.96

Continues on next page...

Hydrograph Discharge Table

Time (hrs)	Hyd. 4 + (cfs)	Hyd. 5 = (cfs)	Outflow (cfs)
1.62	7.89	0.00	7.89
1.63	7.83	0.00	7.83
1.65	7.77	0.00	7.77
1.67	7.70	0.00	7.70
1.68	7.64	0.00	7.64
1.70	7.58	0.00	7.58
1.72	7.51	0.00	7.51
1.73	7.45	0.00	7.45
1.75	7.39	0.00	7.39
1.77	7.33	0.00	7.33
1.78	7.27	0.00	7.27
1.80	7.21	0.00	7.21
1.82	7.15	0.00	7.15
1.83	7.08	0.00	7.08
1.85	7.03	0.00	7.03
1.87	6.97	0.00	6.97
1.88	6.90	0.00	6.90
1.90	6.82	0.00	6.82
1.92	6.74	0.00	6.74
1.93	6.66	0.00	6.66
1.95	6.58	0.00	6.58
1.97	6.51	0.00	6.51
1.98	6.43	0.00	6.43
2.00	6.36	0.00	6.36
2.02	6.28	0.00	6.28
2.03	6.21	0.00	6.21
2.05	6.14	0.00	6.14
2.07	6.07	0.00	6.07
2.08	6.00	0.00	6.00
2.10	5.93	0.00	5.93
2.12	5.86	0.00	5.86
2.13	5.79	0.00	5.79
2.15	5.73	0.00	5.73
2.17	5.65	0.00	5.65
2.18	5.58	0.00	5.58
2.20	5.51	0.00	5.51
2.22	5.43	0.00	5.43
2.23	5.36	0.00	5.36
2.25	5.29	0.00	5.29
2.27	5.23	0.00	5.23
2.28	5.16	0.00	5.16
2.30	5.09	0.00	5.09
2.32	5.02	0.00	5.02
2.33	4.95	0.00	4.95
2.35	4.89	0.00	4.89
2.37	4.82	0.00	4.82
2.38	4.75	0.00	4.75
2.40	4.68	0.00	4.68
2.42	4.62	0.00	4.62
2.43	4.55	0.00	4.55
2.45	4.49	0.00	4.49

Continues on next page...

Hydrograph Discharge Table

Time (hrs)	Hyd. 4 + (cfs)	Hyd. 5 = (cfs)	Outflow (cfs)
2.47	4.43	0.00	4.43
2.48	4.37	0.00	4.37
2.50	4.31	0.00	4.31
2.52	4.25	0.00	4.25
2.53	4.21	0.00	4.21
2.55	4.16	0.00	4.16
2.57	4.11	0.00	4.11
2.58	4.06	0.00	4.06
2.60	4.01	0.00	4.01
2.62	3.96	0.00	3.96
2.63	3.92	0.00	3.92
2.65	3.87	0.00	3.87
2.67	3.83	0.00	3.83
2.68	3.78	0.00	3.78
2.70	3.74	0.00	3.74
2.72	3.69	0.00	3.69
2.73	3.64	0.00	3.64
2.75	3.59	0.00	3.59
2.77	3.54	0.00	3.54
2.78	3.49	0.00	3.49
2.80	3.44	0.00	3.44
2.82	3.39	0.00	3.39
2.83	3.35	0.00	3.35
2.85	3.30	0.00	3.30
2.87	3.25	0.00	3.25
2.88	3.21	0.00	3.21
2.90	3.16	0.00	3.16
2.92	3.12	0.00	3.12
2.93	3.07	0.00	3.07
2.95	3.03	0.00	3.03
2.97	2.99	0.00	2.99
2.98	2.95	0.00	2.95
3.00	2.92	0.00	2.92
3.02	2.88	0.00	2.88
3.03	2.85	0.00	2.85
3.05	2.82	0.00	2.82
3.07	2.79	0.00	2.79
3.08	2.76	0.00	2.76
3.10	2.73	0.00	2.73
3.12	2.70	0.00	2.70
3.13	2.67	0.00	2.67
3.15	2.64	0.00	2.64

...End

Hydrograph Report

Hyd. No. 7

Res Offsite

Hydrograph type	= Rational	Peak discharge	= 6.46 cfs
Storm frequency	= 100 yrs	Time interval	= 1 min
Drainage area	= 1.4 ac	Runoff coeff.	= 0.65
Intensity	= 7.365 in/hr	Time of conc. (Tc)	= 15 min
IDF Curve	= SedgwickCoKS.IDF	Asc/Rec limb fact	= 1/1

Hydrograph Volume = 0.134 acft

Hydrograph Discharge Table

Time -- Outflow
(hrs cfs)

0.05	1.29
0.07	1.72
0.08	2.15
0.10	2.59
0.12	3.02
0.13	3.45
0.15	3.88
0.17	4.31
0.18	4.74
0.20	5.17
0.22	5.60
0.23	6.03
0.25	6.46 <<
0.27	6.03
0.28	5.60
0.30	5.17
0.32	4.74
0.33	4.31
0.35	3.88
0.37	3.45
0.38	3.02
0.40	2.59
0.42	2.15
0.43	1.72

...End

Hydrograph Report

Hyd. No. 8

Total Offsite

Hydrograph type = Combine
Storm frequency = 100 yrs
Inflow hyds. = 6, 7

Peak discharge = 17.86 cfs
Time interval = 1 min

Hydrograph Volume = 2.496 acft

Hydrograph Discharge Table

Time (hrs)	Hyd. 6 + (cfs)	Hyd. 7 = (cfs)	Outflow (cfs)
0.10	1.83	2.59	4.42
0.12	2.40	3.02	5.41
0.13	3.14	3.45	6.59
0.15	3.95	3.88	7.83
0.17	4.99	4.31	9.30
0.18	6.21	4.74	10.95
0.20	7.48	5.17	12.65
0.22	8.88	5.60	14.48
0.23	10.21	6.03	16.24
0.25	11.29	6.46 <<	17.75
0.27	11.83	6.03	17.86 <<
0.28	12.25	5.60	17.86
0.30	12.58	5.17	17.75
0.32	12.83	4.74	17.57
0.33	13.01	4.31	17.32
0.35	13.13	3.88	17.00
0.37	13.18 <<	3.45	16.63
0.38	13.18	3.02	16.19
0.40	13.13	2.59	15.71
0.42	13.04	2.15	15.19
0.43	12.91	1.72	14.64
0.45	12.75	1.29	14.04
0.47	12.55	0.86	13.41
0.48	12.31	0.43	12.74
0.50	12.04	0.00	12.04
0.52	11.98	0.00	11.98
0.53	11.93	0.00	11.93
0.55	11.87	0.00	11.87
0.57	11.81	0.00	11.81
0.58	11.75	0.00	11.75
0.60	11.69	0.00	11.69
0.62	11.64	0.00	11.64
0.63	11.58	0.00	11.58
0.65	11.52	0.00	11.52
0.67	11.47	0.00	11.47
0.68	11.41	0.00	11.41
0.70	11.35	0.00	11.35
0.72	11.29	0.00	11.29

Continues on next page...

Hydrograph Discharge Table

Time (hrs)	Hyd. 6 + (cfs)	Hyd. 7 = (cfs)	Outflow (cfs)
0.73	11.23	0.00	11.23
0.75	11.17	0.00	11.17
0.77	11.11	0.00	11.11
0.78	11.04	0.00	11.04
0.80	10.98	0.00	10.98
0.82	10.92	0.00	10.92
0.83	10.86	0.00	10.86
0.85	10.79	0.00	10.79
0.87	10.73	0.00	10.73
0.88	10.67	0.00	10.67
0.90	10.60	0.00	10.60
0.92	10.54	0.00	10.54
0.93	10.48	0.00	10.48
0.95	10.41	0.00	10.41
0.97	10.35	0.00	10.35
0.98	10.29	0.00	10.29
1.00	10.23	0.00	10.23
1.02	10.16	0.00	10.16
1.03	10.10	0.00	10.10
1.05	10.04	0.00	10.04
1.07	9.97	0.00	9.97
1.08	9.91	0.00	9.91
1.10	9.85	0.00	9.85
1.12	9.78	0.00	9.78
1.13	9.72	0.00	9.72
1.15	9.66	0.00	9.66
1.17	9.60	0.00	9.60
1.18	9.53	0.00	9.53
1.20	9.47	0.00	9.47
1.22	9.41	0.00	9.41
1.23	9.34	0.00	9.34
1.25	9.28	0.00	9.28
1.27	9.22	0.00	9.22
1.28	9.15	0.00	9.15
1.30	9.09	0.00	9.09
1.32	9.03	0.00	9.03
1.33	8.96	0.00	8.96
1.35	8.90	0.00	8.90
1.37	8.84	0.00	8.84
1.38	8.78	0.00	8.78
1.40	8.71	0.00	8.71
1.42	8.65	0.00	8.65
1.43	8.59	0.00	8.59
1.45	8.52	0.00	8.52
1.47	8.46	0.00	8.46
1.48	8.40	0.00	8.40
1.50	8.34	0.00	8.34
1.52	8.27	0.00	8.27
1.53	8.21	0.00	8.21
1.55	8.14	0.00	8.14
1.57	8.08	0.00	8.08

Continues on next page...

Hydrograph Discharge Table

Time (hrs)	Hyd. 6 + (cfs)	Hyd. 7 = (cfs)	Outflow (cfs)
1.58	8.02	0.00	8.02
1.60	7.96	0.00	7.96
1.62	7.89	0.00	7.89
1.63	7.83	0.00	7.83
1.65	7.77	0.00	7.77
1.67	7.70	0.00	7.70
1.68	7.64	0.00	7.64
1.70	7.58	0.00	7.58
1.72	7.51	0.00	7.51
1.73	7.45	0.00	7.45
1.75	7.39	0.00	7.39
1.77	7.33	0.00	7.33
1.78	7.27	0.00	7.27
1.80	7.21	0.00	7.21
1.82	7.15	0.00	7.15
1.83	7.08	0.00	7.08
1.85	7.03	0.00	7.03
1.87	6.97	0.00	6.97
1.88	6.90	0.00	6.90
1.90	6.82	0.00	6.82
1.92	6.74	0.00	6.74
1.93	6.66	0.00	6.66
1.95	6.58	0.00	6.58
1.97	6.51	0.00	6.51
1.98	6.43	0.00	6.43
2.00	6.36	0.00	6.36
2.02	6.28	0.00	6.28
2.03	6.21	0.00	6.21
2.05	6.14	0.00	6.14
2.07	6.07	0.00	6.07
2.08	6.00	0.00	6.00
2.10	5.93	0.00	5.93
2.12	5.86	0.00	5.86
2.13	5.79	0.00	5.79
2.15	5.73	0.00	5.73
2.17	5.65	0.00	5.65
2.18	5.58	0.00	5.58
2.20	5.51	0.00	5.51
2.22	5.43	0.00	5.43
2.23	5.36	0.00	5.36
2.25	5.29	0.00	5.29
2.27	5.23	0.00	5.23
2.28	5.16	0.00	5.16
2.30	5.09	0.00	5.09
2.32	5.02	0.00	5.02
2.33	4.95	0.00	4.95
2.35	4.89	0.00	4.89
2.37	4.82	0.00	4.82
2.38	4.75	0.00	4.75
2.40	4.68	0.00	4.68
2.42	4.62	0.00	4.62

Continues on next page...

Hydrograph Discharge Table

Time (hrs)	Hyd. 6 + (cfs)	Hyd. 7 = (cfs)	Outflow (cfs)
2.43	4.55	0.00	4.55
2.45	4.49	0.00	4.49
2.47	4.43	0.00	4.43
2.48	4.37	0.00	4.37
2.50	4.31	0.00	4.31
2.52	4.25	0.00	4.25
2.53	4.21	0.00	4.21
2.55	4.16	0.00	4.16
2.57	4.11	0.00	4.11
2.58	4.06	0.00	4.06
2.60	4.01	0.00	4.01
2.62	3.96	0.00	3.96
2.63	3.92	0.00	3.92
2.65	3.87	0.00	3.87
2.67	3.83	0.00	3.83
2.68	3.78	0.00	3.78
2.70	3.74	0.00	3.74
2.72	3.69	0.00	3.69
2.73	3.64	0.00	3.64
2.75	3.59	0.00	3.59

...End

Appendix I

Pipe Sizing Calculations

